

DRAINAGE CRITERIA MANUAL
FOR
Jefferson County Drainage District No. 7
Jefferson County, Texas

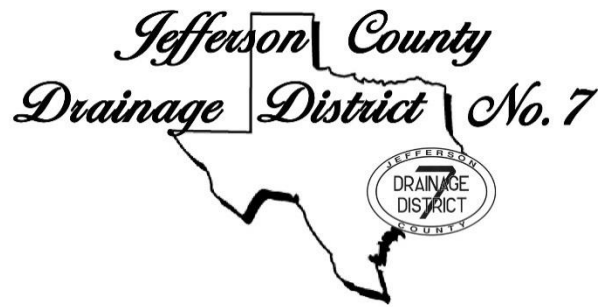

November 2019

Prepared by
LJA ENGINEERING, INC.



CONTENTS

LIST OF FIGURES

1. PURPOSE AND POLICIES.....	1
1.1 PURPOSE OF THE DRAINAGE CRITERIA MANUAL	1
1.2 DRAINAGE POLICIES	2
1.3 THE NATIONAL FLOOD INSURANCE PROGRAM	3
2. REVIEW AND APPROVAL OF DRAINAGE PLANS.....	0
2.1 ADVISORIES.....	0
2.2 OVERVIEW OF APPROVAL PROCESS.....	0
2.3 TYPES OF SUBMITTALS	0
2.4 ACTIVITIES FOR WHICH SUBMITTALS TO DD7 ARE REQUIRED	1
2.5 GENERAL REQUIREMENTS FOR VARIOUS SUBMITTALS	2
2.6 REVIEW & APPROVAL OF SUBMITTALS TO THE ENGINEERING DEPARTMENT.....	7
3. HYDROLOGIC & HYDRAULIC CONCEPTS	8
3.1 DEFINITIONS OF BASIC TECHNICAL TERMS.....	8
3.2 BASIC HYDROLOGIC CONCEPTS	9
3.3 BASIC HYDRAULIC CONCEPTS.....	10
3.4 EFFECTS OF URBANIZATION.....	11
3.5 FLOOD INSURANCE CONCEPTS.....	12
4. HYDROLOGY	0
4.1 DRAINAGE AREAS UP TO 200 ACRES	0
4.2 DRAINAGE AREAS GREATER THAN 200 ACRES	4
5. HYDRAULICS OF PRIMARY DRAINAGE FACILITIES.....	0
5.1 GENERAL DESIGN REQUIREMENTS FOR PRIMARY DRAINAGE FACILITIES 0	
5.2 HYDRAULIC ANALYSIS OF PRIMARY DRAINAGE FACILITIES.....	7
6. HYDRAULICS OF SECONDARY DRAINAGE FACILITIES	0
6.1 GENERAL DESIGN REQUIREMENTS FOR STORM SEWERS	0
6.3 DESIGN OF ROADSIDE DITCHES.....	6
6.4 DESIGN OF OTHER SECONDARY DRAINAGE FACILITIES	7
6.5 LOT GRADING AND DRAINAGE.....	8
7. DETENTION ANALYSIS	0
7.1 GENERAL DESIGN REQUIREMENTS	0
7.2 PEAK DISCHARGE RATES.....	3

LIST OF FIGURES

7.3	DETENTION ANALYSIS FOR DRAINAGE AREAS UP TO 200 ACRES	4
8.	EROSION AND SEDIMENT CONTROL	0
8.1	EFFECTS OF EROSION AND SEDIMENTATION	0
8.2	AREAS WITH HIGH EROSION POTENTIAL.....	0
8.3	SLOPE PROTECTION METHODS	1
8.4	REQUIREMENTS FOR CHANNEL BENDS AND CONFLUENCES	3
8.5	REQUIREMENTS FOR STORM SEWER OUTFALLS	4
8.6	CHANNEL BACKSLOPE DRAIN SYSTEMS	4
8.7	INTERCEPTOR STRUCTURES.....	5
8.8	STORM WATER POLLUTION PREVENTION PLANS	5
8.9	SPECIAL ENERGY DISSIPATION STRUCTURES.....	5

APPENDIX A. DRAINAGE DISTRICT NO. 7 STANDARDS

FIGURE 4-1:	HEC-HMS Rainfall Data Window
FIGURE 4-2:	HEC-HMS Subbasin Model Editor Loss Rate Window
FIGURE 4-3:	HEC-HMS Subbasin Model Editor Transformation Window
FIGURE 4-4:	HEC-HMS Modified Puls Routing Reach Window
FIGURE 4-5:	HEC-HMS Hydrograph Combining Schematic
FIGURE 7-1:	Downstream Impacts Analysis Process

LIST OF TABLES

TABLE 4-1:	Rational Method Coefficients for 2- to 10-Year Storms
TABLE 4-2:	Rational Method Runoff Coefficient Adjustment Factors
TABLE 4-3:	Rainfall Intensity Parameters for Jefferson County, Texas
TABLE 4-4:	Rainfall Data for Drainage District No. 7, Jefferson County, Texas
TABLE 4-5:	Green & Ampt Parameters
TABLE 4-6:	SCS Curve Numbers
TABLE 4-7:	Percent Impervious Cover Values for Jefferson County, Texas
TABLE 5-1:	Minimum Thickness and Reinforcement for Concrete Slope Paving
TABLE 5-5:	Maximum Allowable Velocities in Open Channels
TABLE 5-3:	Frequencies of Coincidental Occurrence for Determining Tailwater Elevations in Receiving Channels
TABLE 5-4:	Manning's Roughness Coefficients
TABLE 5-5:	Parameters Used in Computing Channel Roughness Coefficients
TABLE 5-6:	Parameters Used in Computing Floodplain Roughness Coefficients
TABLE 5-7:	Manning's Roughness Coefficients for Culverts
TABLE 5-8:	Entrance Loss Coefficients for Culverts
TABLE 5-9:	FHWA Chart and Scale Numbers
TABLE 6-1:	Minimum and Maximum Allowable Slopes for Storm Sewers
TABLE 6-2:	Minor Loss Coefficients for Inlets and Manholes
TABLE 7-1:	100-year Rainfall Excess Values for Jefferson County, Texas
TABLE 8-1:	Minimum Thickness and Reinforcement for Concrete Slope Paving
TABLE 8-2:	Maximum Allowable Velocities in Open Channels
TABLE 8-3:	Minimum Erosion Protection for Channel Confluences
TABLE 8-4:	Minimum Extent of Erosion Protection at Confluences

LIST OF EXHIBITS

- EXHIBIT 3-1: Sketch of the Hydrologic Cycle
- EXHIBIT 3-2: Relationship between Unit and Runoff Hydrographs
- EXHIBIT 3-3: Concepts Associated with Manning's Equation
- EXHIBIT 3-4: Relationship between the 100-Year Floodplain and Floodway
- EXHIBIT 3-5: Typical Jefferson County Flood Insurance Rate Map

- EXHIBIT 4-1: SCS Uplands Method
- EXHIBIT 4-2: Watershed with Multiple Sub-areas
- EXHIBIT 4-3: USGS WRIR 98-4044 IDF Curves for Jefferson County

- EXHIBIT 5-1: Typical Section Grass-Lined Trapezoidal Channel
- EXHIBIT 5-2: Typical Section Concrete-Lined Trapezoidal Channel
- EXHIBIT 5-3: Typical Cross-Section, Concrete-Lines with Rectangular Low-Flow Section

- EXHIBIT 6-1: Typical Storm Sewer Outfall Structure (24-Inch to 42-Inch)
- EXHIBIT 6-2: Typical Storm Sewer Outfall Structure (48-Inch and Larger)
- EXHIBIT 6-3: Typical Storm Sewer and Channel Interaction
- EXHIBIT 6-4: Undesirable Sheet Flow Patterns
- EXHIBIT 6-5: Acceptable Sheet Flow Patterns
- EXHIBIT 6-6: Requirements for Lot Drainage Design (Cross-Section View)
- EXHIBIT 6-7: Requirements for Lot Drainage Design (Plan View)

- EXHIBIT 7-1: Typical Detention Basin Layout
- EXHIBIT 7-2: Typical Detention Basin Cross-Section
- EXHIBIT 7-3: Detention Storage Volume for Drainage Areas up to 200 Acres

- EXHIBIT 8-1: Slope Protection Requirements at Stream Confluences
- EXHIBIT 8-2: Slope Protection Requirements at Channel Bends
- EXHIBIT 8-3: Typical Storm Sewer Outfall Structure (24 in. to 42 in.)
- EXHIBIT 8-4: Typical Storm Sewer Outfall Structure (48 in. and larger)
- EXHIBIT 8-5: Typical Roadside Ditch Interceptor Structure
- EXHIBIT 8-6: Typical Backslope Interceptor Structure
- EXHIBIT 8-7: Typical Rock Check Dam

1. PURPOSE AND POLICIES

1.1 PURPOSE OF THE DRAINAGE CRITERIA MANUAL

The primary purpose of this drainage criteria manual is to establish standard principles and practices for the analysis, design, and construction of primary drainage systems within Jefferson County Drainage District No. 7 (DD7). This Drainage Criteria Manual is issued to support the Master Drainage Plan and Drainage Regulations that have been adopted by the Jefferson County Drainage District No. 7 pursuant to the authority set forth in the Texas Water Code §49.211. The regulations are accessible online at www.dd7.org. Paper copies may be obtained at the offices of DD7.

The manual is for users with knowledge and experience in the applications of standard engineering principles and practices of drainage design and management. It is the purpose of this Drainage Criteria Manual to outline criteria and guidance to be used by developers, engineers, and land surveyors in the design of drainage measures to manage rainfall-runoff. These criteria shall be used unless otherwise approved by the DD7 General Manager.

Storm water management is an essential component of community infrastructure and serves to provide both increased convenience and protection of life and property. A properly designed system will detain and/or carry away runoff from more frequent rainfall events while allowing the movement of vehicles to homes and businesses. Such a system will also detain and/or drain storm water from an infrequent “extreme rainfall event” so that habitable structures are not damaged and major streets are passable to public safety vehicles.

Providing Jefferson County and the incorporated municipalities within the boundaries of DD7 with an effective storm water management system that allows sustainable community growth is a continuing challenge. It involves setting minimum standards, planning for future detention basins and drainage channels, working with private development interests, coordinating with governmental agencies, and maintaining the efficiency of the existing system.

Recognizing that storm water system development should be guided by adopted policies and criteria, DD7 launched a planning process aimed at setting consistent standards responsive to the needs of property developers and design engineers and compliant with federal and state regulations. This *Drainage Criteria Manual* applies to all areas within the Jefferson County Drainage District No. 7 jurisdiction, and overrides any and all less stringent city or county codes of ordinance covered within this Manual. If the project falls within the jurisdiction of DD7, the submittals related to the project must initially be sent to DD7 for approval. Approval will be determined by DD7 according to whether or not the project is in compliance with this *Drainage Criteria Manual*.

This manual is not intended to interfere with, abrogate, or annul any other ordinance, rule, or regulation, statute, or other provision of law. Where any provision imposes restrictions different from those imposed by Jefferson County or an incorporated municipality within the boundaries of DD7, whichever provisions are more restrictive or impose higher standards shall control.

These regulations do not address pipelines and utilities. DD7 has administrative procedures for applications for construction, maintenance, and repair of pipelines and utilities that are proposed within the DD7's facilities and easements. Contact the DD7 office to obtain the Pipeline/Utility Permit Application Packet, which is also available on DD7.org.

1.2 DRAINAGE POLICIES

1.2.1 Zero Impact (No Adverse Impacts)

An impact is defined as a change in the response of a watershed to a storm event. The most common impacts are changes in the volume of runoff, changes in the rate of runoff, and changes in flooding depths. Impacts may be adverse or beneficial. Adverse impacts are those which increase the potential for flooding damages. Beneficial impacts, on the other hand, reduce the potential for flood damage. The term zero impact is normally defined as the absence of adverse impact. DD7 maintains a strict zero impact policy in all watersheds located wholly or partially within the boundaries of DD7. This means that neither increases in upstream flood levels nor in downstream flow rates are allowed in areas where there is the potential for flooding damages from storms with recurrence intervals of 100 years or less.

Adverse impacts associated with new development must be identified and mitigated. Acceptable mitigation measures may include storm water detention, creation of new flood plain storage, channel improvements, and improvements to channel structures. A "zero impact" policy will be enforced by DD7. No adverse impacts on downstream peak flow rates or upstream flood levels will be allowed and no net loss in existing flood plain storage will be allowed within the DD7 boundaries.

1.2.2 Level of Protection

The level of protection is generally regarded as the storm recurrence interval which future primary drainage facilities, such as open channels, roadway culverts, and detention facilities, are designed to accommodate without significant flooding damages. For example, providing a 100-year level of protection would indicate that the future primary drainage facilities are designed to carry storm runoff from a 100-year storm event without significant flooding of homes and other buildings. For the analysis and design of future primary drainage facilities, DD7 has adopted a 100-year level of protection.

1.2.3 Storm Water Detention

Storm water detention refers to the temporary storage of storm runoff in ponds or other storage facilities. The provision of this temporary storage allows storm runoff to be discharged to a receiving stream at a lower rate, thereby protecting downstream areas from increased flooding damages associated with increased flow rates and higher flood levels. DD7 recognizes the value of storm water detention in reducing the potential for flood damages and allows the use of detention facilities in addition to adding conveyance capacity for mitigating impacts associated with new development and drainage improvements.

1.2.4 Flood Plain Storage

Flood plain storage is defined for the purposes of this manual as the space below 100-year flood levels. This space is available for the temporary storage of flood waters during extreme storm events. Preservation of this air space is extremely important because flood plain storage serves to reduce downstream peak flow rates. DD7 prohibits reductions in existing flood plain storage along all streams which pass through the boundaries of DD7.

1.2.5 Primary and Secondary Drainage Facilities

For the purposes of this manual, primary drainage facilities include open channels, bridges, culverts, and enclosed drainage systems (i.e., open channel that has been enclosed). Secondary drainage facilities include storm sewer systems, roadside ditches and associated structures, and other facilities such as sheet flow swales, small culverts, and other structures which typically serve relatively small drainage areas, as well as lot grading and drainage requirements.

1.3 THE NATIONAL FLOOD INSURANCE PROGRAM

Jefferson County and the municipalities within the County are participants in the National Flood Insurance Program (NFIP). This program provides federally subsidized flood insurance to those cities and counties which elect to participate. The program is administered by the Federal Emergency Management Agency (FEMA), which is headquartered in Washington, D.C. Flood insurance data for participating cities and counties is published by FEMA in two formats: bound flood insurance studies, which describe the results of flooding studies completed for significant streams, and Flood Insurance Rate Maps (FIRMs), which provide data on 100-year flood levels, illustrate the boundaries of the floodway, 100-year flood plain, and 500-year flood plain, and designate flood hazard zones for insurance purposes.

2. REVIEW AND APPROVAL OF DRAINAGE PLANS

2.1 ADVISORIES

2.1.1 Engineering Judgment

The design requirements, criteria, and schematics included in this manual establish uniform practices for design of drainage associated with subdivisions and developments. However, the requirements of this manual neither replace the need for engineering judgment on behalf of designers, nor does it preclude the use of methods not presented. Other accepted methods and procedures may be used with prior approval of the DD7 engineering staff.

2.1.2 Deviations

Deviations from the DD7 drainage regulations and this manual, if known or anticipated, shall be identified and discussed at a pre-submission conference or by other means. Deviations are to be identified in the drainage report and the technical justification for such deviations, including computations as appropriate, shall be provided. The acceptability of the deviations shall be determined by the DD7 engineering staff.

2.1.3 Requirements of Other Jurisdictions

It is the responsibility of the Applicant/Owner to obtain any and all approvals required by Jefferson County, or the other municipalities, or any other agency of the State of Texas or the United States of America. Evidence that such approvals have been applied for or obtained may be required by the District prior to issuance of an Approval.

2.2 OVERVIEW OF APPROVAL PROCESS

The District's procedures are described in the Drainage Regulations. The following is an overview of the review and approval process. In the event of conflict, the Regulations shall prevail.

A pre-submission conference is strongly recommended. The District acknowledges that drainage concerns, the adequacy of the existing drainage system and access for maintenance, and solutions to address inadequacies and flooding that may be exacerbated by new development vary from location to location. The purpose of the pre-submission conference is to improve understanding of the existing drainage system in the vicinity of and downstream of the proposed subdivision or development site and to discuss measures that are necessary and appropriate to address drainage and flooding. The DD7 engineering staff may provide information, data and computer models from DD7 engineering studies, and evidence of drainage and flooding concerns based on observations and data collected from past storm and flood events.

DD7 reserves the right to require a pre-submission conference.

2.3 TYPES OF SUBMITTALS

The types of engineering submittals typically made in connection with new development or drainage studies include the following:

- **Engineering Reports:** These documents, which may take the form of letter reports or more extensive and formal bound reports, normally describe the results of analyses of existing and/or proposed drainage conditions. Engineering reports may be submitted as a basis for better understanding of existing conditions (i.e., a flood plain revision report), to support a request for approval of construction documents for a proposed facility (i.e., a preliminary engineering report for a roadway improvement project), or to serve as a plan for future conditions (i.e., a master drainage report for a given watershed).
- **Construction Documents:** These include engineering drawings and specifications for a proposed facility or development which will affect storm water drainage or flood control.
- **Permit Applications:** These are applications for development permits, flood plain fill permits, pipeline or other crossing permits, and other permits required by DD7.

2.4 ACTIVITIES FOR WHICH SUBMITTALS TO DD7 ARE REQUIRED

DD7 requires that engineering submittals be prepared for all activities which may affect the rate, direction, or volume of storm water runoff, or the depth and velocity of flow in primary drainage facilities and other infrastructure within DD7's jurisdiction as applicable. Drainage criteria for secondary drainage facilities is shown in section 6 of this manual but is subordinate to local municipal and county requirements. DD7 will review the following three types of projects:

1. Construction of new projects, modification and/or improvement of existing facilities, or impacting the existing facilities which are maintained by DD7, which include:
 - a. Open channels
 - b. Bridges, culverts, and other hydraulic structures associated with open channels
 - c. Detention basins
 - d. Pump stations
2. Construction of drainage facilities which are physically located in, on, over, under, or adjacent to a drainage facility maintained by DD7:
 - a. Land development projects
 - b. Roads and highways
 - c. Bridges and culverts
 - d. Storm sewer outfall pipes
 - e. Water and sanitary sewer lines
 - f. Pipelines and public utilities
 - g. Environmental features (tree plantings, landscaping, etc.)
 - h. Recreation amenities (hike and bike trails, parks, etc.)
 - i. Encroachments
3. Development or public projects that may affect the facilities maintained by DD7 such as natural channels, lakes, drainage-ways, etc. or future drainage facilities described in a drainage master plan:

- a. Proposed subdivision development
- b. Residential, commercial, and industrial site development
- c. Roads and highways

2.5 GENERAL REQUIREMENTS FOR VARIOUS SUBMITTALS

The various submittals presented to DD7 for review should be as complete and as well-documented as possible. If project locations are within the boundaries of DD7, the general requirements described in this section should be satisfied for all submittals and act as standards with priority over any city or county, within DD7's boundaries, codes that are less stringent. The intent of these requirements is to insure that the following aspects of the proposed activity are made clear to the reviewer:

2.5.1 New Development

Submittals for all new development shall include the following items:

- a plat of the development illustrating property boundaries, individual lot boundaries, streets, drainage easements, etc.
- a hydrologic impact analysis which identifies the potential effects of the development on downstream peak flow rates.
- if necessary, a hydraulic impact analysis which identifies the potential effects of the development on upstream flood levels.
- a preliminary engineering report which presents the results of impact analyses, describes proposed mitigation measures, provides construction cost estimates, etc.

Preliminary construction plans for proposed streets, storm drainage facilities, utilities, and other features may be submitted along with the preliminary engineering report. Final construction plans should be prepared after DD7 has completed its review of the report and issued written comments.

2.5.2 Hydrologic Studies

Major watershed hydrologic studies will be summarized in a report which contains sufficient text, exhibits, and computer output to completely describe the methods, data, and assumptions used in the analysis, as well as the results obtained. Information provided in the report should include the following:

- a description of the analysis and the results obtained
- tabulations of all hydrologic modeling parameters
- tabulations of all computed peak flow rates
- a watershed map which illustrates the borders of each sub-area included in watershed modeling
- a hydrologic parameter map which illustrates all watercourse lengths, drainage areas, and developed areas

- output from all hydrologic models used in the analysis
- a computer diskette or compact disk containing input files for all hydrologic and hydraulic models

2.5.3 Hydraulic Studies of Primary Drainage Facilities

For hydraulic analyses and designs of primary drainage system components, an engineering report containing the following items should be submitted:

- sufficient text to summarize the methods, data, and assumptions used in completing the analysis, as well as the results obtained
- calculations and other information supporting the flow rates used in the analysis
- tabulations of hydraulic modeling data and results
- vicinity and site maps which illustrate the location of the project area and the extent of the stream reach being analyzed
- a plotted stream profile(s)
- plotted cross-sections of the stream with computed flood levels superimposed
- a copy of the effective Flood Insurance Rate Map (FIRM) for the project area and, as needed, a proposed conditions flood plain and floodway map which illustrates proposed changes in flood plain and floodway boundaries
- copies of all hydraulic calculations
- an analysis of the effects of proposed improvements on downstream peak flow rates and upstream flood levels
- recommendations for mitigating any adverse impacts associated with proposed improvements to channels or structures
- output from all hydraulic computer models used in the analysis
- a computer diskette containing input files for all hydraulic models

For studies involving improvements to open channels and hydraulic structures or designs of new open channels, a right-of-way (ROW) map should also be submitted. Preliminary construction plans may be submitted along with the engineering report. Final plans should be prepared after DD7 has completed its review of the engineering report and issued comments.

2.5.4 Hydraulic Studies of Secondary Drainage Facilities

For submittals involving the design of storm sewer systems, ditches, swales, and other secondary drainage facilities which will have a direct effect on any DD7 properties, rights-of-way, or facilities, the following items should be included:

- a report which summarizes the methods, data, and assumptions used in completing the design analysis, as well as the results obtained
- vicinity and site maps which illustrate the location of the project area and the location and configuration of the proposed facilities
- a watershed map which illustrates the boundaries of all sub-areas included in the analysis of the proposed facilities
- calculations and other information supporting the flow rates used in the analysis
- hydraulic calculations used in designing the facilities and in assessing their hydraulic performance under design storm conditions
- an analysis of the effects of proposed improvements on downstream peak flow rates and upstream flood levels
- recommendations for mitigating any adverse impacts associated with proposed drainage improvements
- a plotted profile(s) of the storm sewer system, ditch, swale, etc.
- for ditches and swales, a typical cross-section(s)
- output from computer programs used in the analysis
- a computer diskette or compact disk containing input files for any computer programs used in the analysis

Preliminary construction plans may be submitted along with the engineering report. Final plans should be prepared after DD7 has completed its review of the engineering report and issued comments.

2.5.5 Detention Studies

The following information must be submitted in support of designs for detention facilities:

- vicinity, site, and watershed maps which clearly illustrate the location of the facility, its physical extents and configuration, its drainage area, and the relationship of its drainage area to the overall boundaries of the major watershed in which it is located
- a ROW map which illustrates all existing and proposed ROWs in the immediate vicinity of the detention facility
- discharge calculations which identify peak flow rates for pre-development and post-development conditions for the design storm event

- hydraulic calculations on which the design of the detention discharge structure is based
- for facilities with a drainage area of less than 200 acres, calculations establishing the required detention storage volume
- for facilities having a drainage area of 200 acres or more, a detention flood routing analysis which assesses the effectiveness of the detention basin in mitigating impacts on downstream peak flow rates
- calculations involving the required capacity of supplemental and/or emergency discharge structures
- exhibits which illustrate the configuration of the detention facility, inflow structure, and discharge structure
- benchmark information
- a soils report which discusses the suitability of the soil for construction of the proposed facilities

These items should be submitted in supported of a written report which describes the proposed location and configuration of the detention facility, the methods used in the design of the facility, and the conclusions of the detention analysis with regard to the effectiveness of the facility in mitigating increases in downstream peak flow rates. Preliminary construction plans may be submitted along with the engineering report. Final plans should be prepared after DD7 has completed its review of the engineering report and issued comments

2.5.6 General Engineering Report Requirements

It is recommended that engineering reports be prepared in such a manner as to include all of the necessary information without referencing previous submittals. Each report should utilize text, tables, and exhibits to thoroughly document the methods, data, and assumptions used in completing analyses of the proposed activity as well as the results obtained. Detailed computations and computer printouts should be attached to the report in the form of appendices. All reports should be bound to insure that the report text, exhibits, and attachments stay together. All reports and accompanying materials should be submitted in a manageable format. Maps should be 24" x 36" or smaller. All maps and other exhibits must be legible and information should be presented a clear and concise manner.

The following exhibits and calculations should be submitted with engineering reports as appropriate:

- **Vicinity Map:** A map showing the project site with respect to recognizable landmarks in the vicinity. This could be a city map with the boundaries of a new development or the limits of a channel improvement project indicated to mark the project location.
- **Site Map:** This is a detailed map of the project site which illustrates the type and extent of activities which are proposed to be completed. For new developments, a plat with all proposed streets, lot boundaries, etc. may be used to satisfy this requirement.

- **Watershed or Drainage Map:** A watershed or drainage map which illustrates all drainage boundaries, flow directions, and computation points.
- **Discharge Calculations:** Calculations specifying computed discharges at key locations, with comparisons of existing and proposed discharges where appropriate. Drainage areas, runoff coefficients, rainfall depths and intensities, infiltration loss parameters, unit hydrograph parameters, and other applicable hydrologic data should be included and clearly documented. For computer applications, printouts should be attached.
- **Hydraulic Calculations:** Hydraulic calculations specifying the methods used in analyzing channels, storm sewers, and other hydraulic structures and providing a summary of the results obtained. Cross-section data, roughness coefficients, flow rates, and other data should be clearly documented. For computer applications, printouts should be attached.
- **Benchmark Information:** A description of the benchmark used to establish existing and proposed elevations in the project area, including the exact location, the elevation, and the source of the elevation.
- **Right-of-Way Map:** A map which illustrates existing and proposed channel and utility ROWs and easements. Include both underground and overhead utilities and all drainage easements. Sufficient ROW must be permanently set aside to allow for the construction of the most extensive permanent drainage facilities proposed to pass through the development in the future. These facilities may include open or enclosed channels, storm sewers, ditches, or swales. For channels, the width of the ROW must be adequate to provide for the channel itself plus minimum maintenance berm widths. For enclosed systems, the minimum ROW width is equal to the widest dimension of the underground conduit plus two times the maximum depth from finished ground to the invert of the conduit, or 30 feet, whichever is greatest
- **Soils Report:** A soils report, prepared by a qualified geotechnical engineer, which identifies the existing soil types and assesses the suitability of the soil for the proposed activity. The soils report should address erosion and slope stability in areas subject to the action of storm runoff.
- **Plotted Stream Profile:** A profile of the subject stream which includes computed water surface profiles, existing and proposed flow-line profiles, the locations of existing and proposed bridges, culverts, and utility crossings, the locations of tributary confluences and major storm sewer outfalls in or near the project area, and the locations of hydraulic structures such as dams, weirs, and drop structures.
- **Plotted Cross-Sections:** Typical cross-sections of the subject stream for both existing and proposed conditions.
- **Flood Plain Maps:** A FIRM showing the boundaries of the existing 100-year flood plain and floodway in the project area and a separate map which illustrates proposed changes in flood plain or floodway boundaries.
- **Facility Layout Map:** Plan, elevation, and cross-section views of drainage facilities such as detention basins, roadway culverts, bridges.

- **Erosion Control:** All drainage facilities must be designed and maintained in a manner which minimizes the potential for damage due to erosion. No bare earthen slopes will be allowed. Various slope treatments, including turf establishment, concrete slope paving, and rip-rap, are accepted. Flow velocities should be kept below permissible values for each type of slope treatment. Interceptor structures and backslope swale systems are required to prevent sheet flows from eroding the side slopes of open channels and detention facilities.

2.6 REVIEW & APPROVAL OF SUBMITTALS TO THE ENGINEERING DEPARTMENT

Upon receiving an engineering submittal, representatives of Jefferson County Drainage District No. 7 will check it for completeness and will request additional information as needed. Upon receiving all of the information necessary to thoroughly evaluate the submittal, DD7 will complete the review. Written comments will be forwarded to the submitter, who will make any corrections or adjustments to the analysis and re-submit a final package. Upon determining that all necessary corrections and adjustments have been made, DD7 will prepare a written acceptance of the submittal.

3. HYDROLOGIC & HYDRAULIC CONCEPTS

The purpose of this chapter is to present a brief summary of hydrologic and hydraulic concepts that are required to understand and apply the criteria presented in this manual. This chapter also includes a description of the effects of urbanization on the watershed as well as a description of the National Flood Insurance Program (NFIP).

3.1 DEFINITIONS OF BASIC TECHNICAL TERMS

- **conveyance:** the ability of a channel or conduit to carry water in the downstream direction
- **cross-sectional area:** the total area available to carry flow, measured at a vertical plane (cross-section), which cuts across a channel or conduit perpendicular to the direction of flow.
- **flood plain:** an area inundated by flood waters during or after a storm event of a specific magnitude.
- **friction loss:** a loss in energy associated with friction between flowing water and the sides of a channel or conduit
- **hydraulic radius:** a parameter computed as the cross-sectional area divided by the wetted perimeter
- **hydrology:** the study of the processes through which atmospheric moisture passes between the time that it falls to the surface of the earth as rainfall and the time that it returns to the atmosphere.
- **hydrograph:** a graph which relates rate of flow and time
- **infiltration:** the process by which rainfall soaks into the ground
- **Manning's Equation:** a mathematical formula which relates the velocity or rate of flow in a channel or conduit to the physical characteristics of the channel or conduit
- **minor loss:** a loss in energy associated with changes in flow direction or velocity
- **probability:** the chance, usually expressed in percent, that a storm event of a particular intensity and duration will occur in any given year; equal to the reciprocal of the recurrence interval
- **rainfall intensity:** the rate at which rainfall occurs, typically expressed in inches per hour
- **recurrence interval:** the average period of time which will elapse between storms of a particular intensity and duration (equal to the reciprocal of the probability)
- **roughness coefficient:** a number which represents the relative resistance to flow in a channel or conduit
- **runoff:** precipitation which does not infiltrate into the ground, but instead makes its way to a storm water drainage facility
- **storm event:** a single period of heavy rainfall, normally lasting from a few minutes to a few days

- **time of concentration:** the time required for water to travel from the most remote point in a watershed to the point at which a peak flow rate or runoff hydrograph is to be computed
- **unit hydrograph:** a runoff hydrograph which represents the response of a watershed to 1 inch of runoff
- **watercourse:** a path which water follows from the boundary of a watershed to the watershed outlet
- **wetted perimeter:** the total distance along a channel or conduit cross-section that is in contact with water that is flowing in the channel or conduit

3.2 BASIC HYDROLOGIC CONCEPTS

3.2.1 The Hydrologic Cycle

The term hydrologic cycle refers to a series of processes through which moisture falls to earth as precipitation, and returns to the atmosphere. The basic processes involved in the hydrologic cycle include rainfall, infiltration, interflow, storage, evaporation, and transpiration. Exhibit 3-1 illustrates the interaction of these processes.

3.2.2 Design Rainfall Events

Rainfall normally occurs in irregular patterns with respect both to space and time. However, synthetic rainfall events (referred to as “design storm events”) are typically used for hydrologic analyses. These design storm events are developed through statistical analyses of long periods of recorded rainfall data and are defined by the recurrence interval and storm duration. For example, a 100-year, 24-hour storm is a 24-hour duration design storm which has a one-percent probability of occurring in any given year. Table 4-4 provides a summary of the relationship between rainfall depth, duration, and recurrence interval for Jefferson County Drainage District 7.

3.2.3 Infiltration & Runoff

A portion of the rainfall that reaches the earth soaks into the ground via infiltration, while the balance of the rainfall is called runoff (Exhibit 3-1). Since infiltration increases with the porosity of the soil, infiltration for clay soils is less than for sandy soils. Infiltration is reduced as the moisture content of the soil is increased and ceases when the soil becomes saturated. As infiltration decreases, runoff increases and vice versa.

3.2.4 Runoff Hydrographs

Runoff hydrographs are relationships between the rate of runoff and time. Hydrographs are important because they provide information on the peak rate of runoff and variations in runoff rates throughout the duration of a particular storm event. These variations can be significant in defining the response of a watershed to a rainfall event, especially when the watershed is large and runoff continues over many hours or days.

A unit hydrograph is a hydrograph which reflects the response of a watershed to a rainfall event that produces exactly one-inch of runoff. Runoff hydrographs for storm events producing more or less than one-inch of runoff are computed from a unit hydrograph by multiplying each individual flow rate in the unit hydrograph by the actual runoff volume in inches. This computation is based on various hydrologic parameters and is performed automatically by software programs such as HEC-HMS, which was developed by the Hydrologic Engineering Center of the U.S. Army Corps of Engineers (USACE). Exhibit 3-2 illustrates the relationship between unit hydrographs and runoff hydrographs.

3.3 BASIC HYDRAULIC CONCEPTS

3.3.1 Manning's Equation

Manning's equation is a commonly used formula that relates the hydraulic capacity and the physical condition of an open channel, a storm sewer pipe, or a box culvert. The equation is written as follows:

$$Q = \left(\frac{1.49}{n} \right) AR^{2/3} S^{1/2} \quad \text{Equation 3-1}$$

where: Q = the flow rate (cubic feet per second);
 n = a roughness coefficient related to the relative condition of the channel or structure;
 A = the cross-sectional area of flow (square feet);
 R = the hydraulic radius, which is computed as the flow area divided by the wetted perimeter (feet);
 S = the slope of the channel or structure;

The roughness coefficient (n value) is a measure of the roughness of the surfaces with which water comes into contact. For example, higher n values represent rougher surfaces and lower n values represent smoother surfaces. Information on selecting n values for open channels and storm sewers is included in Chapter 5. Exhibit 3-3 illustrates some of the basic concepts associated with Manning's Equation.

3.3.2 Conveyance

Conveyance is a measure of the capacity of a channel, flood plain, or hydraulic structure to carry storm water. As indicated in Equation 3-2, conveyance increases with the cross-sectional area of flow, the depth of flow in the structure, and the smoothness of the surfaces with which water comes into contact. For example, enlarging a drainage channel will increase the conveyance and the rate of storm water flow within the channel. Clearing away trees and brush from a channel will have the same effect. Replacing a corrugated metal pipe (CMP) with a reinforced concrete pipe (RCP) of the same diameter also results in an increased conveyance because of the smoother interior of the RCP.

$$K = \frac{1.49}{n} AR^{2/3} \quad \text{Equation 3-2}$$

where: K = conveyance (cubic feet per second).

3.4 EFFECTS OF URBANIZATION

Urbanization includes activities such as land clearing, new development, roadway construction, improvements to drainage systems, changes in natural land topography, placement of fill in flood plains, and construction of pavements and other impervious surfaces. These types of activities have significant effects on the response of a watershed to rainfall, which are summarized below.

- **Increased Volume of Runoff:** Urbanization is typically accompanied by an increase in the percentage of the ground surface that is covered by impervious materials, which decreases infiltration and increases the volume of runoff.
- **Increased Rate of Runoff:** In most urbanized areas, drainage systems are designed to collect and convey storm water as efficiently as possible away from areas occupied by homes, businesses, and roadways. This efficiency tends to concentrate storm water runoff more quickly than the natural drainage system in most areas. In addition, re-grading of natural slopes and the removal of flow-retarding vegetation eliminates natural storage that attenuates runoff rates in non-urbanized areas. These factors cause runoff rates from urbanized areas to exceed rates from undeveloped areas, which tends to increase the water surface elevations (WSELs) in channels.
- **Modified Watershed Response:** The increased efficiency of urban drainage systems tends to decrease the time of concentration from developed drainage areas so that the peak runoff rate occurs more quickly than from the same area prior to development. As a result, development of a drainage area may adversely impact WSELs within the receiving channel due to changes in the timing of peak runoff rates. These adverse impacts may occur even if detention is provided and the developed peak runoff rate is less than the undeveloped peak runoff rate.

- **Reduced Flood Plain Conveyance:** Lots and/or building pads located in flood-prone areas are typically elevated with fill material. The placement of this material in flood plains creates obstructions to flow and reduces the available conveyance in the flood plain. The construction of elevated roads across the flood plain has a similar effect. Such reductions in the conveyance capacity of the flood plain tend to increase WSELs in channels.

3.5 FLOOD INSURANCE CONCEPTS

The purpose of the NFIP, which is administered by the Federal Emergency Management Agency (FEMA), is to offer affordable flood insurance for homes and businesses located in flood-prone areas. Delineations of flood-prone areas are completed in Flood Insurance Studies (FIS) commissioned by individual participants (typically cities and counties) in the program. FEMA publishes the results of these studies as bound FIS and as Flood Insurance Rate Maps (FIRMs). The purpose of FIS is to define areas with a certain chance of flooding. The 100-year rainfall event, which has a one-percent probability of occurring in any given year, is used as a standard measure. However, FIS and FIRMs are not intended to indicate with certainty that a particular area will or will not flood over a given period of time.

FIS include hydrologic studies to define peak flow rates along studied streams for 10-, 50-, 100-, and 500-year rainfall events. Hydraulic analyses are also performed to establish base flood elevations (BFEs) along studied streams for each of these rainfall events and to define the boundaries of the 100- and 500-year flood plains as well as the floodway. As shown on Exhibit 3-4, the floodway is a corridor of effective flow that includes the channel and any adjacent land areas required to pass the 100-year peak discharge rates without increasing the WSEL at any point along the channel more than one-foot above the 100-year BFEs. FIRMs provide data on 100-year BFEs, illustrate the boundaries of the floodway and 100- and 500-year flood plains, and designate flood hazard zones for insurance purposes (Exhibit 3-5). The irregular lines drawn across the 100-year flood plain at one-foot intervals indicate the BFEs along the stream.

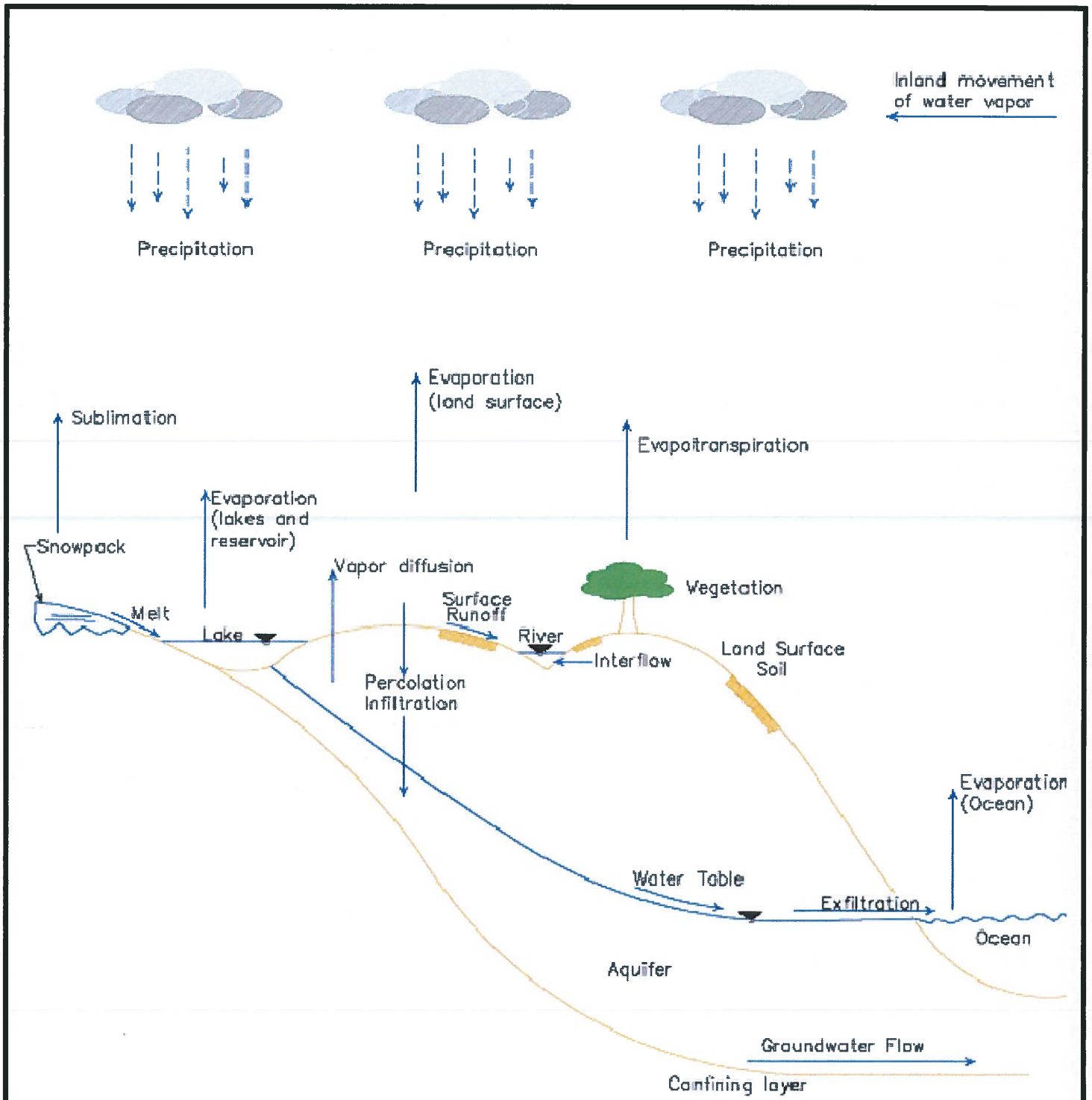

SKETCH OF THE HYDROLOGIC CYCLE



DRAINAGE
CRITERIA
MANUAL

EXHIBIT #: 3-1

DATE: SEPTEMBER 2018

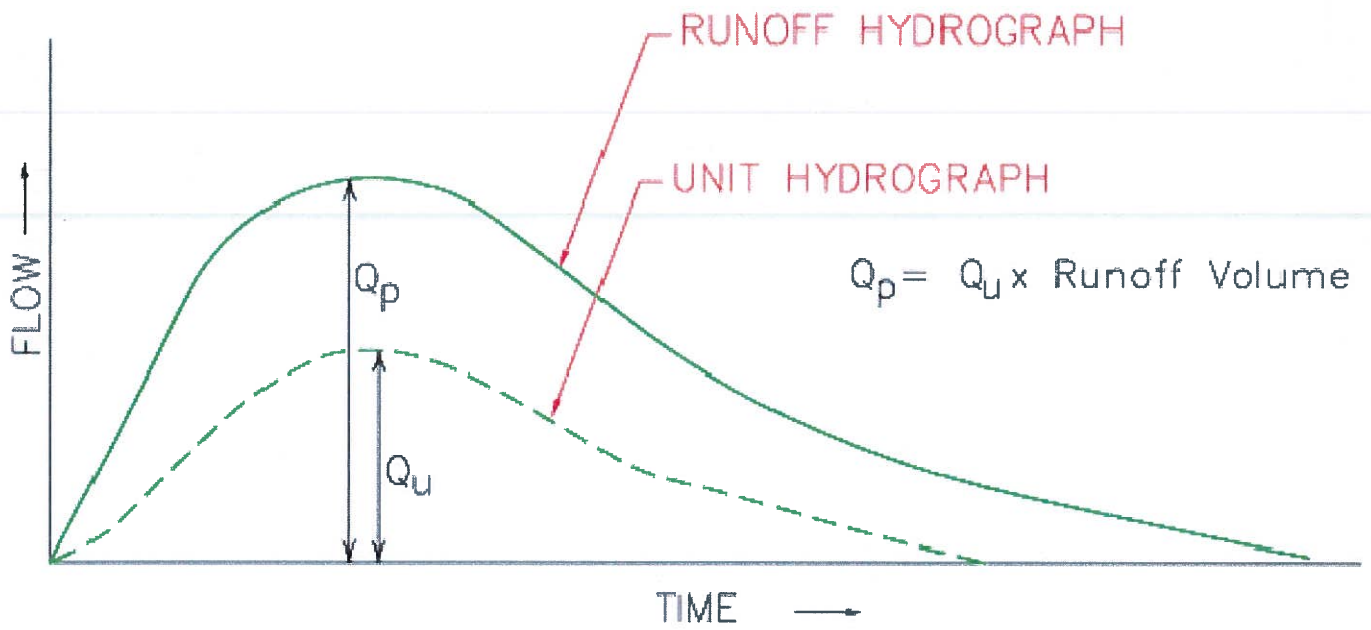

RELATIONSHIP BETWEEN
UNIT AND RUNOFF HYDROGRAPHS



DRAINAGE
CRITERIA
MANUAL

EXHIBIT #: 3-2

DATE: SEPTEMBER 2018

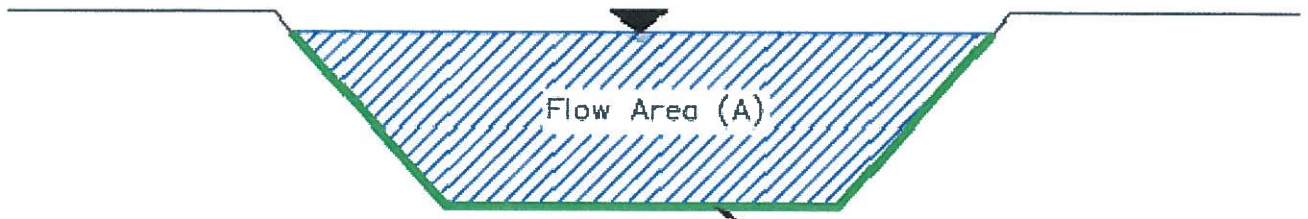

Flow Area (A)

Wetted Perimeter (P)

$$R = \frac{A}{P}$$

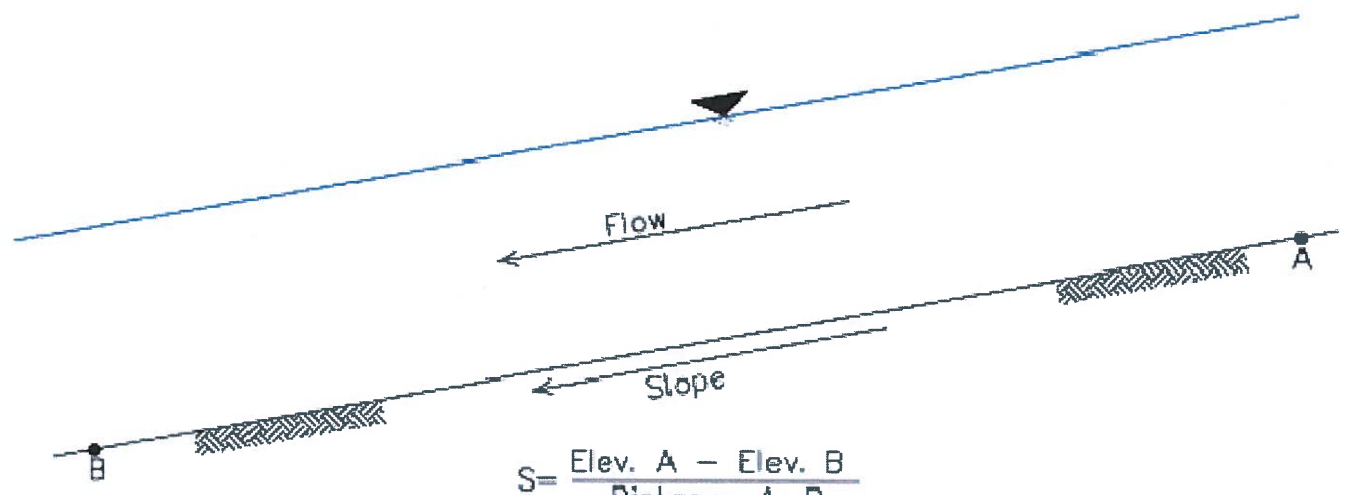

$$S = \frac{\text{Elev. A} - \text{Elev. B}}{\text{Distance A-B}}$$

CONCEPTS ASSOCIATED WITH
MANNING'S EQUATION



DRAINAGE
CRITERIA
MANUAL

EXHIBIT #: 3-3
DATE: SEPTEMBER 2018

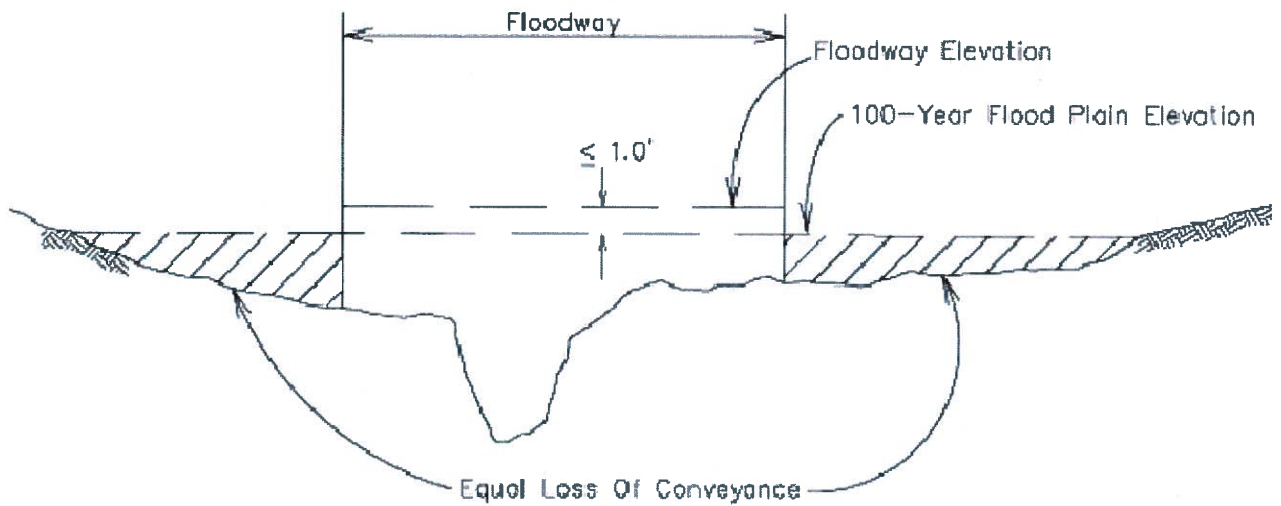

CHANNEL CROSS-SECTION A-A

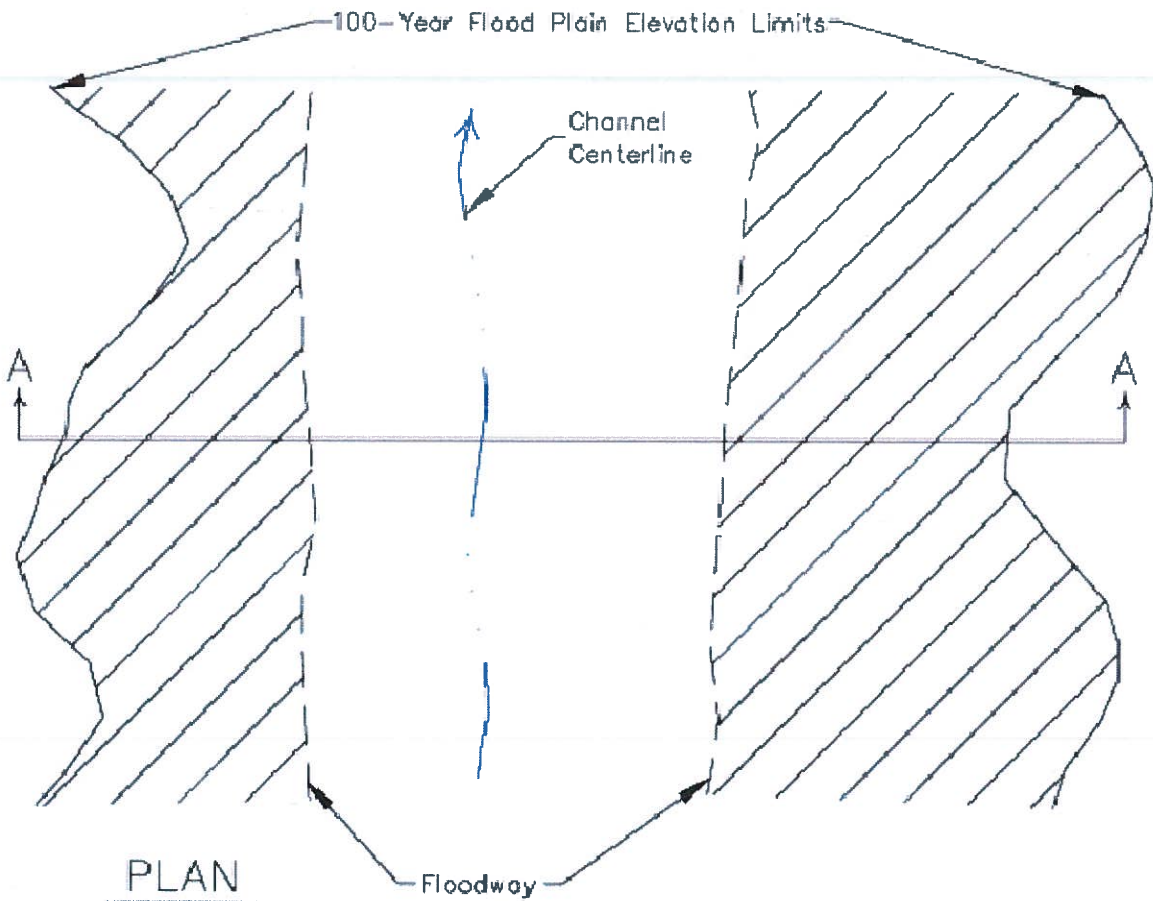

PLAN

RELATIONSHIP BETWEEN THE
100-YEAR FLOOD PLAIN AND FLOODWAY



DRAINAGE
CRITERIA
MANUAL

EXHIBIT #: 3-4

DATE: SEPTEMBER 2018

ELEVATION REFERENCE MARKS

REFERENCE MARKS	ELEVATION FT. (M) ¹ 431	DESCRIPTION OF LOCATION
100	100	1. General Flood Control and Maintenance Project, located on the south side of the main channel of the river, about 1/4 mile west of the mouth of the river, about 1/4 mile west of the mouth of the river, about 1/4 mile west of the mouth of the river, about 1/4 mile west of the mouth of the river.
200	200	2. General Flood Control and Maintenance Project, located on the north side of the main channel of the river, about 1/4 mile east of the mouth of the river, about 1/4 mile east of the mouth of the river, about 1/4 mile east of the mouth of the river.
300	300	3. General Flood Control and Maintenance Project, located on the south side of the main channel of the river, about 1/4 mile east of the mouth of the river, about 1/4 mile east of the mouth of the river, about 1/4 mile east of the mouth of the river.
400	400	4. General Flood Control and Maintenance Project, located on the north side of the main channel of the river, about 1/4 mile east of the mouth of the river, about 1/4 mile east of the mouth of the river, about 1/4 mile east of the mouth of the river.

500 YEAR FLOOD PLAIN

100 YEAR FLOOD PLAIN

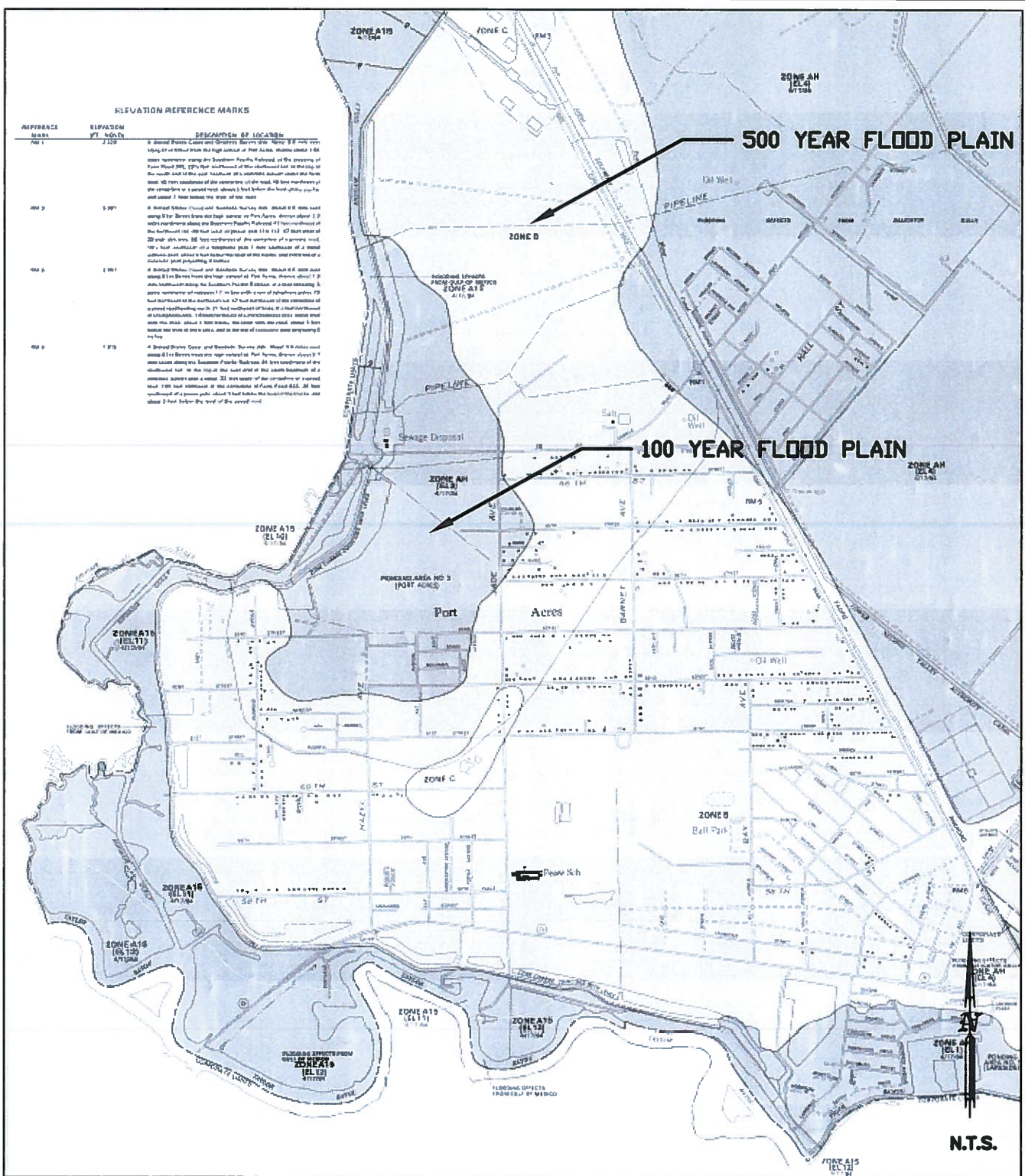

N.T.S.

TYPICAL JEFFERSON COUNTY FLOOD INSURANCE RATE MAP



DRAINAGE CRITERIA MANUAL

EXHIBIT #: 3-5

DATE: SEPTEMBER 2018

4. HYDROLOGY

The purpose of this chapter is to provide detailed information on the hydrologic analyses required by DD7. This chapter is divided into two main sections. Section 4.1 describes requirements for the hydrologic analysis of drainage areas up to 200 acres, while Section 4.2 describes requirements for the hydrologic analysis of drainage areas greater than 200 acres.

4.1 DRAINAGE AREAS UP TO 200 ACRES

4.1.1 Introduction

This section describes the methods to be used in hydrologic analyses of drainage areas up to 200 acres. These analyses may be completed using the Rational Method. However, a HEC-HMS hydrologic analysis can also be performed for drainage areas up to 200 acres using the methodology described in Section 4.2.

4.1.2 The Rational Method

The Rational Method relates the runoff rate from a watershed to drainage area, land use, and rainfall intensity. The basic equation used in the Rational Method to compute the runoff rate is:

$$Q = C \times C_a \times I \times A \qquad \text{Equation 4-1}$$

where: Q = the peak runoff rate (cubic feet per second);
 C = a runoff coefficient dependent on land use;
 C_a = a runoff coefficient adjustment factor dependent on the storm recurrence interval;
 I = the rainfall intensity (inches per hour);
 A = the drainage area (acres).

4.1.3 Establishing the Drainage Area

Drainage areas for Rational Method analyses should be established using topographic maps, storm sewer layouts, and other available information. At each computation point, the drainage area is defined as the total area contributing runoff at that location.

4.1.4 Determining Runoff Coefficients

Table 4-1 provides a summary of runoff coefficients for various land uses, overland slopes, and soil types. The appropriate runoff coefficient may be selected by establishing the land use and consulting this table. For example, an area developed as an apartment complex on land which slopes at less than one-percent would have a runoff coefficient of 0.75. Land use data may be obtained from zoning maps, aerial photographs, and site visits.

CHAPTER 4: HYDROLOGY

**TABLE 4-1: RATIONAL METHOD COEFFICIENTS
FOR 2- TO 10-YEAR STORMS**

Description of Area	Basin Slope		
	< 1%	1% - 3.5%	> 3.5%
Single-Family Residential Districts			
<i>Lots greater than 1/2 acre</i>	0.30	0.35	0.40
<i>Lots 1/4 to 1/2 acre</i>	0.40	0.45	0.50
<i>Lots less than 1/4 acre</i>	0.50	0.55	0.60
Multi-Family Residential Districts	0.60	0.65	0.70
Apartment Dwelling Areas	0.75	0.80	0.85
Business Districts			
<i>Downtown</i>	0.85	0.87	0.90
<i>Neighborhood</i>	0.75	0.80	0.85
Industrial Districts			
<i>Light</i>	0.50	0.65	0.80
<i>Heavy</i>	0.60	0.75	0.90
<i>Railroad Yard Areas</i>	0.20	0.30	0.40
<i>Cemeteries</i>	0.10	0.18	0.25
<i>Playgrounds</i>	0.20	0.28	0.35
Streets			
<i>Asphalt</i>	0.80	0.80	0.80
<i>Concrete</i>	0.85	0.85	0.85
<i>Concrete Drives and Walks</i>	0.85	0.85	0.85
<i>Roofs</i>	0.85	0.85	0.85
Lawn Areas			
<i>Sandy Soil</i>	0.05	0.08	0.12
<i>Clay Soil</i>	0.15	0.18	0.22
Woodlands			
<i>Sandy Soil</i>	0.15	0.18	0.25
<i>Clay Soil</i>	0.18	0.20	0.30
Pasture			
<i>Sandy Soil</i>	0.25	0.35	0.40
<i>Clay Soil</i>	0.30	0.40	0.50
Cultivated			
<i>Sandy Soil</i>	0.30	0.55	0.70
<i>Clay Soil</i>	0.35	0.60	0.80

CHAPTER 4: HYDROLOGY

For drainage areas with multiple land uses, runoff coefficients and drainage areas associated with each land use shall be determined. The composite runoff coefficient shall then be computed using Equation 4-2:

$$C_w = \frac{\sum (C_i \times A_i)}{A_T} \quad \text{Equation 4-2}$$

where: C_w = weighted runoff coefficient;
 C_i = runoff coefficients for various land uses;
 A_i = drainage areas corresponding to values of C_i (acres);
 A_T = total drainage area (acres).

As indicated previously, a runoff coefficient adjustment factor (C_a) shall be used to adjust peak runoff rates for various recurrence intervals. Table 4-2 lists the runoff coefficient adjustment factors for storm recurrence intervals ranging from two to 100 years.

TABLE 4-2: RATIONAL METHOD RUNOFF COEFFICIENT ADJUSTMENT FACTORS	
Storm Recurrence Interval (years)	Adjustment Factor (C_a)
2 - 10	1.00
25	1.10
50	1.20
100	1.25

4.1.5 Establishing the Time of Concentration

The time of concentration (T_C) is defined as the time (in minutes) required for all portions of the watershed to contribute runoff at the computation point. The T_C is normally calculated by identifying the longest flow path within the watershed and estimating the time required for runoff to travel the entire length of this path. Storm water runoff may pass through a range of flow conditions as it moves along the longest flow path. Overland sheet flow is characterized by very shallow depths of less than two inches. Within a short distance of about 100 to 300 feet, storm water runoff begins to flow at greater depths to collect in streets, swales, and small ditches or gullies, and is commonly known as concentrated overland flow. Finally, the runoff collects in storm sewers, creeks, and drainage channels in which flow depths may reach several feet.

In order to estimate T_C , the longest flow path is divided into reaches that represent the various types of flow conditions and the flow velocity for each individual reach is estimated. For example, the longest flow path may include overland sheet flow, concentrated flow in a roadside ditch, and flow in a drainage channel. Flow velocities for overland sheet flow and some concentrated flow conditions may be estimated using the Uplands Method, which relates flow velocity to overland slope and land use. This method was developed by the U.S. Department of Agriculture Soil

CHAPTER 4: HYDROLOGY

Conservation Service (SCS). Exhibit 4-1 provides a graphical representation of the Uplands Method.

For storm sewers, creeks, and channels, flow velocities may be estimated using Manning's equation or a HEC-RAS model (see Chapter 5). The length of each individual reach is divided by the flow velocity to obtain the time of travel required for water to pass through the reach, and T_c is calculated as the sum of the individual travel times.

4.1.6 Computation of Rainfall Intensity

The rainfall intensity (I) for a particular frequency used in the Rational Method may be determined from Equation 4-3, which was developed by the Texas Department of Transportation (TxDOT) from the U.S. Weather Bureau publications *Technical Paper No. 40* and *Hydrometeorological Report No. 35*. The values are currently being updated by TxDOT based on NOAA Atlas 14, volume 11.

$$I = \frac{b}{(T_c + d)^e} \quad \text{Equation 4-3}$$

where: I = rainfall intensity (inches per hour);
 T_c = time of concentration (minutes);
 b, d, e = rainfall intensity parameters from Table 4-3.

If the calculated T_c is less than 10 minutes, then a T_c of 10 minutes should be used in Equation 4-3.

THE JEFFERSON COUNTY INTENSITY PARAMETERS TABLE IS CURRENTLY BEING EVALUATED WITH RESPECT TO NOAA ATLAS 14 RAINFALL DEPTHS – 4-1-2019

TABLE 4-3: RAINFALL INTENSITY PARAMETERS FOR JEFFERSON COUNTY, TEXAS			
CONSTANTS FOR JEFFERSON COUNTY			
Storm Frequency	<i>e</i>	<i>b</i>	<i>d</i>
2-Year	0.7483	50.81	10.05
5-Year	0.7479	67.46	11.62
10-Year	0.7462	80.10	12.61
25-Year	0.7426	95.12	13.51
50-Year	0.7408	109.47	13.99
100-Year	0.7416	128.88	15.31

Note: The rainfall data presented above is the latest available as of the date of the Drainage Criteria Manual issuance. DD7 may adopt revised data not reflected in this table. It is the

CHAPTER 4: HYDROLOGY

engineer's responsibility to ensure that current accepted rainfall intensity information is being utilized for the analysis.

4.1.7 Analyzing a Watershed with Multiple Sub-Areas or Computation Points

When analyzing a watershed with multiple sub-areas or computation points, the peak flow rate at the computation point located furthest upstream is computed first. Peak flow rates are computed at subsequent points, while moving in the downstream direction. At each point, the total drainage area is determined and T_C is computed for the longest flow path from the most remote point in the entire watershed to the current computation point. Exhibit 4-2 shows a typical layout of a small watershed with multiple sub-areas and computation points. The rainfall intensity for the peak flow rate computation is calculated using this T_C . As discussed in Section 4.1.4, a weighted runoff coefficient shall be computed using the coefficients for individual sub-areas upstream of the computation point.

4.2 DRAINAGE AREAS GREATER THAN 200 ACRES

This section describes the methods to be used in hydrologic analyses of drainage areas greater than 200 acres. These analyses shall be completed using the HEC-HMS computer program developed at the Hydrologic Engineering Center of the U.S. Army Corps of Engineers (USACE). This software program can be downloaded from the USACE's website (<http://www.hec.usace.army.mil/software/hec-hms/hechms-download.html>) at no charge. The *Hydrologic Modeling System HEC-HMS User's Manual*, the *Hydrologic Modeling System HEC-HMS Applications Guide*, and the *Hydrologic Modeling System HEC-HMS Technical Reference Manual* developed by the USACE can be used for further reference. These manuals can also be downloaded from the USACE's website (<http://www.hec.usace.army.mil/software/hec-hms/hechms-document.html>) at no charge. The hydrologic parameters discussed in Sections 4.2.1 to 4.2.5 are the basis for developing HEC-HMS models.

4.2.1 Watershed Boundaries

Topographic information, storm sewer layouts, and other available information shall be used to provide the level of detail necessary to delineate additional sub-area boundaries as needed. These boundaries may be delineated by hand or with HEC-GeoHMS, which is a *Geographic Information Systems (GIS)* program that works in conjunction with ArcView to compute hydrologic parameters. However, HEC-GeoHMS sub-area boundaries should be closely reviewed by an engineer familiar with the topography of the drainage area. The number of sub-areas required for the HEC-HMS analysis is a function of the number of computation points, which are typically established at confluences with tributaries, roadway crossings, or other points of interest (lakes and reservoirs, etc). Normally, there is one sub-area above the first analysis point and one or more between each pair of successive analysis points. In addition, there is at least one sub-area for each tributary.

CHAPTER 4: HYDROLOGY

4.2.2 Rainfall Data

The rainfall depth-duration-frequency data for Jefferson County Drainage District No. 7 listed in Table 4-4 was acquired from NOAA Atlas 14, volume 11, Version 2, Port Arthur SE TX, and shall be used in HEC-HMS hydrologic analyses. Exhibit 4-3 illustrates the IDF curves developed from previous NOAA datasets by TxDOT. The curves are currently being updated based on the Atlas 14 data. The rainfall depth data and exceedance probability associated with the design storm event shall be entered in the meteorological model of HEC-HMS. A one-percent exceedance probability would be entered for a 100-year storm event, four-percent would be entered for a 25-year event, and twenty-percent would be entered for a 5-year event.

A maximum intensity-duration of five minutes shall be used for the analysis regardless of the design storm event. A value of 67-percent is used as the peak center and the HEC-HMS program automatically distributes the rainfall over a 24-hour period in such a manner that the maximum rainfall intensity occurs at approximately two-thirds of storm event. Rainfall leading up to and following the period of maximum intensity is distributed in a manner which produces a balanced rainfall distribution. Since the use of the total area option in HEC-HMS is problematic for many types of hydrologic analysis, point rainfall data is used for Jefferson County's Drainage District No. 7 and a total storm area of 0.01 square miles, or other approved area, is used to compute runoff hydrographs. A base flow of zero shall be used unless project-specific considerations warrant the use of this parameter.

TABLE 4-4: RAINFALL DATA FOR DRAINAGE DISTRICT No. 7								
NOAA Atlas 14, volume 11, Version 2, Port Arthur SE TX								
Recurrence Interval (years)	Rainfall Depth (inches) for Given Duration							
	15 MIN	30 MIN	1 HR	2 HR	3 HR	6 HR	12 HR	24 HR
2	1.23	1.77	2.37	3.04	3.45	4.16	4.88	5.63
5	1.52	2.17	2.94	3.88	4.49	5.54	6.54	7.56
10	1.76	2.50	3.40	4.61	5.43	6.84	8.15	9.49
25	2.08	2.95	4.04	5.66	6.81	8.79	10.6	12.5
50	2.32	3.28	4.51	6.49	7.94	10.5	12.8	15.1
100	2.57	3.62	5.01	7.40	9.21	12.3	15.3	18.3
500	3.22	4.59	6.52	10.1	12.9	17.9	22.7	27.6

CHAPTER 4: HYDROLOGY

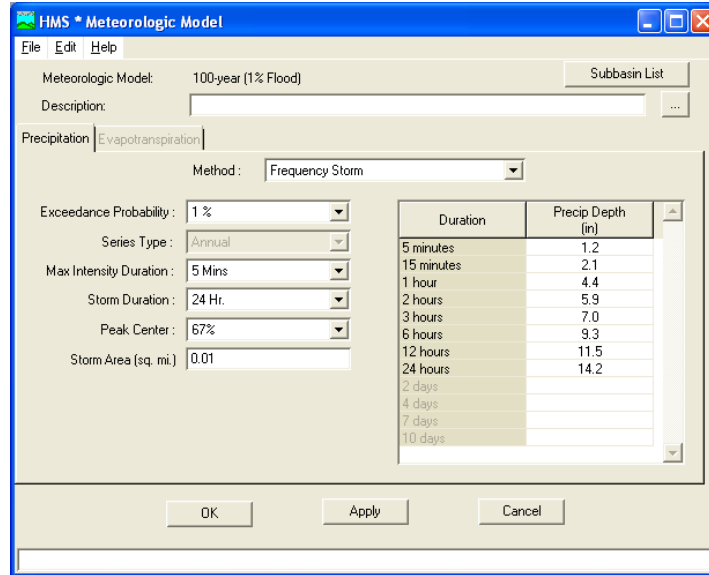

Figure 4-1: HEC-HMS Rainfall Data Window

4.2.3 Infiltration Losses

Infiltration losses shall be accounted for using the Green & Ampt method, which is a conceptual representation of the infiltration process, was developed in 1911 by Green & Ampt. This method estimates infiltration losses based on a function of soil texture and the capacity of the given soil type to convey water. The advantage of this method is that the parameters can be estimated based on soil type. The parameters should be applied on a watershed-wide basis, similar to the exponential and initial/uniform loss methods from the original Flood Hazard Study.

Table 4-5 shows the volume moisture deficit, wetting front suction, and hydraulic conductivity parameters for various soil textures and types. The hydrologic soil group to which a particular soil belongs may be determined by consulting the Soil Survey or the Soil Survey Geographic Database (SSURGO) for Jefferson County, Texas.

CHAPTER 4: HYDROLOGY

TABLE 4-5: GREEN & AMPT LOSS PARAMETERS			
Soil Classification	Volume Moisture Deficit	Wetting Front Suction (inches)	Hydraulic Conductivity (inches/hour)
Soil Texture			
Sand	0.417	1.95	9.276
Loamy Sand	0.402	2.41	2.354
Sandy Loam	0.412	4.33	0.858
Loam	0.436	3.50	0.520
Silt Loam	0.486	6.57	0.268
Sandy Clay Loam	0.330	8.60	0.118
Clay Loam	0.389	8.22	0.079
Silty Clay Loam	0.431	10.75	0.079
Sandy Clay	0.321	9.41	0.047
Silty Clay	0.423	11.50	0.039
Clay	0.385	12.45	0.024
Soil Group			
A (freely draining)	0.417	1.95	9.276
B (intermediate)	0.436	3.50	0.520
C (intermediate)	0.389	8.22	0.079
D (poorly draining)	0.385	12.45	0.024

4.2.4 Initial Abstraction

Initial abstraction losses shall be accounted for using the Soil Conservation Service (SCS) Curve Number method, which is an empirical method developed by the U.S. Department of Agriculture. Equation 4-4 can be used to compute the initial abstraction for specific soil types.

$$I_a = 0.2S \qquad \text{Equation 4-4}$$

- where: I_a = the initial abstraction depth (inches);
 S = initial retention = $\frac{1000}{CN} - 10$;
 CN = SCS Curve Number, from Table 4-6.

CHAPTER 4: HYDROLOGY

The Curve Number is a function of soil structure, antecedent watershed moisture, and land use. Soil structure is defined by assigning individual soils to one of four hydrologic soil groups (A through D) that represent a wide range of soil porosities. Soils belonging to hydrologic soil group A are the most porous, while soils in group D are the least porous. The hydrologic soil group may be determined from the Soil Survey for Jefferson County, Texas or the Soil Survey Geographic Database (SSURGO) for Jefferson County. Table 4-6 provides a summary of SCS Curve Numbers for various land uses, taken from the *SCS National Engineering Handbook, Section 4*.

TABLE 4-6: SCS CURVE NUMBERS					
Land Use Description	Hydrologic Soil Group				
	A	B	C	D	
Cultivated Land					
<i>Without Conservation Treatment</i>	72	81	88	91	
<i>With Conservation Treatment</i>	62	71	78	81	
Pasture or Range Land					
<i>Poor Condition</i>	68	79	86	89	
<i>Good Condition</i>	39	61	74	80	
Meadow: Good Condition	30	58	71	78	
Wood or Forest Land					
<i>Thin Stand, Poor Cover, No Mulch</i>	45	66	77	83	
<i>Good Cover</i>	25	55	70	77	
Open Spaces, Lawns, Parks, Cemeteries					
<i>Good Condition, 75% Grass Cover</i>	39	61	74	80	
<i>Poor Condition, 50-75% Grass Cover</i>	49	69	79	84	
Commercial and Business Areas (85% Impervious)	89	92	94	95	
Industrial Districts (72% Impervious)	81	88	91	93	
Residential					
<i>Average Lot Size</i> <i>Average % Impervious</i>					
<i>1/8 acre or less</i> <i>65</i>	77	85	90	92	
<i>1/4 acre</i> <i>38</i>	61	75	83	87	
<i>1/3 acre</i> <i>30</i>	57	72	81	86	
<i>1/2 acre</i> <i>25</i>	54	70	80	85	
<i>1 acre</i> <i>20</i>	51	68	79	84	
Paved Parking Lots, Roofs, Driveways, Etc.	98	98	98	98	
Streets and Roads					
<i>Paved with Curbs and Storm Sewers</i>	98	98	98	98	
<i>Gravel</i>	76	85	89	91	
<i>Dirt</i>	72	82	87	89	

Source: *SCS National Engineering Handbook, Section 4*

CHAPTER 4: HYDROLOGY

For watersheds with varying land uses and soil types, composite Curve Numbers may be computed by determining the Curve Number and drainage area associated with each land use and/or soil category. The composite Curve Number may then be computed using the following equation:

$$CN_w = \sum \frac{(CN_i \times A_i)}{A_T} \quad \text{Equation 4-5}$$

where: CN_w = weighted Curve Number;
 CN_i = Curve Number for various land uses and soil types;
 A_i = drainage areas corresponding to values of CN_i (acres);
 A_T = total drainage area (acres).

In HEC-HMS applications, cumulative totals for rainfall and infiltration are maintained. The total runoff is re-computed for every time step.

4.2.5 Percent Impervious Cover

Percent impervious cover is a function of land urbanization and can be estimated from field observations, aerial photographs, and other supporting information on the drainage area. Table 4-7 provides a summary of percent impervious cover values for different land use categories:

TABLE 4-7: PERCENT IMPERVIOUS COVER VALUES FOR JEFFERSON COUNTY, TEXAS		
Land Use Categories	Land Use Descriptions	% Impervious
Undeveloped	Unimproved, natural, or agricultural	0
Residential – Rural Lot	≥ 5-acre ranch or farm	5
Residential	Average Lot Size	
	1 acre	20
	½ acre	25
	⅓ acre	30
	¼ acre	38
	⅛ acre or less	65
Developed Green Areas	Parks or golf courses	15
Light Industrial/ Commercial	Office parks, nurseries, airports, warehouses, or manufacturing with non-paved areas	60
High Density	Commercial, business, industrial, or apartments	85
Transportation	Highway or major thoroughfare corridors	90

CHAPTER 4: HYDROLOGY

Water	Detention basins, lakes, channels, roadside ditches	100
-------	---	-----

4.2.6 Loss Rate Computations in HEC-HMS

The Green & Ampt loss rate parameters and percent impervious cover values discussed in Sections 4.2.3 to Section 4.2.5 are entered into the loss rate option of the HEC-HMS Subbasin Model Editor window as shown in Figure 4-2.

The screenshot shows the 'Loss Rate' tab in the HEC-HMS Subbasin Model Editor. The 'Method' is set to 'Green & Ampt'. The parameters are as follows:

Parameter	Value
Initial Loss (in)	0.60
Vol. Moisture Deficit	0.426
Wet. Front Suct. (in)	4.78
Conductivity (in/hr)	0.40
Impervious (%)	9.0

Figure 4-2: HEC-HMS Subbasin Model Editor Loss Rate Window

4.2.7 Unit Hydrograph Methodology

Unit hydrographs shall be computed based on the Clark Unit Hydrograph method, which is one of the unit hydrograph methods available in HEC-HMS. The Clark Unit Hydrograph method uses three parameters to define a unit hydrograph for a watershed: the T_C , a storage coefficient, and a time-area curve. The T_C is defined as the time required for all portions of the watershed to contribute runoff at the computation point. Refer to Section 4.1.5 for more information on estimation of T_C . The storage coefficient (R) is an indicator of the available storm water storage volume within a watershed within depressions, ponds, channels and flood plains. The value of R varies directly with the relative amount of storage volume within a watershed (i.e., the greater the storage volume, the higher the storage coefficient). For DD7, R should be estimated from Equation 4-6 or any other methodology approved by DD7.

$$R = 3 \times T_C \quad \text{Equation 4-6}$$

CHAPTER 4: HYDROLOGY

The time-area curve relates the percentage of the watershed contributing runoff at the analysis point to the fraction of the T_C , which has elapsed since the beginning of runoff. The entire watershed is considered to be contributing runoff at the outlet when the elapsed time is equal to or greater than the T_C . This standard curve is applicable as long as extremes in watershed shapes (i.e., very large or very small ratios of watershed length to width) are avoided. Calculation of the time-area curve is handled internally by HEC-HMS with a standard time-area curve based on assumed watershed shape.

Runoff hydrographs can be computed in HEC-HMS by selecting the Clark Unit Hydrograph method from the Transform option of HEC-HMS Subbasin Editor Window. In addition, the T_C and R parameters should be entered for each subbasin. The meteorological model data works in conjunction with the subbasin editor data to calculate a hydrograph for each subbasin. Figure 4-3 illustrates the HEC-HMS transform window.

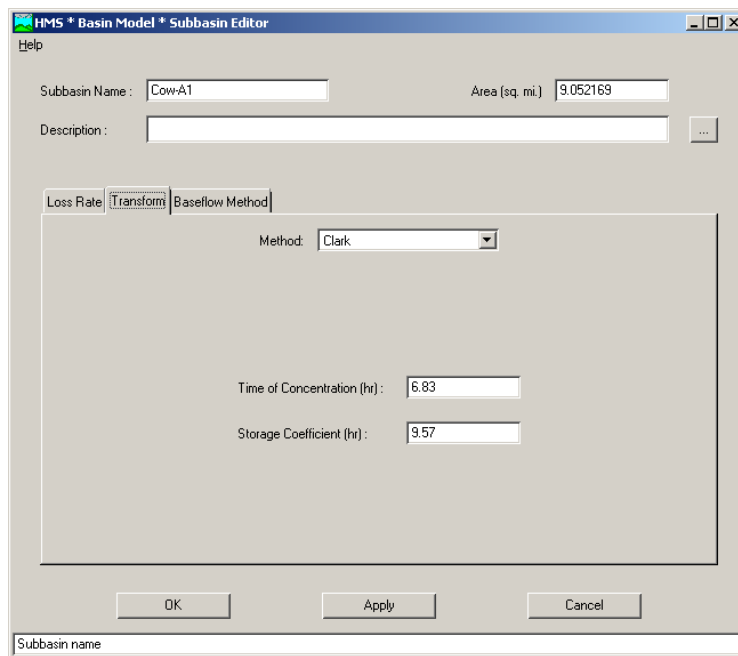

Figure 4-3: HEC-HMS Subbasin Model Editor Transformation Window

4.2.8 Streamflow Routing

Streamflow routing is the process by which the lagging and attenuating effects of travel time and storage on runoff hydrographs are taken into account as flood flows move from one analysis point to another. Although the HEC-HMS program offers a number of streamflow routing methods, DD7 requires the use of the Modified Puls method where channel cross-sections and a HEC-RAS hydraulic model of the channel are available. For streamflow routing along channels without a

CHAPTER 4: HYDROLOGY

HEC-RAS model, the Muskingum-Cunge Standard, Muskingum-Cunge 8-Point, or Muskingum methods should be used depending on which method is best suited to the specific application. However, if backwater conditions and/or overland flooding are anticipated, it is recommended that a HEC-RAS model of the channel be developed and the Modified Puls method be used.

The Modified Puls Method explicitly accounts for the effects of storage volume within the flood plain and is based on a simple continuity equation:

$$\Delta S = I - O \quad \text{Equation 4-7}$$

where: ΔS = change in storage volume within the routing reach;
 I = inflow to the routing reach;
 O = outflow from the routing reach.

For the Modified Puls method, input to the HEC-HMS program consists of a set of flow rates and corresponding storage volumes, which are input in the basin model routing reach window (see Figure 4-4). Additionally, the number of sub-reaches and initial flow condition are selected in the same window. The Muskingum method is an approximation of the continuity equation (Equation 4-7) where storage is modeled as the sum of prism and wedge storage. Required input parameters for this method include: the Muskingum K, Muskingum X (ranges from 0.0 to 0.5), and the number of sub-reaches. Refer to the HEC-HMS documentation mentioned in Section 4.2 for additional information on these routing methods.

Storage (ac ft)	Outflow (cfs)
0.0	0.0
5292.0	951.0
7500.0	1902.0
9648.0	2459.0
10543.0	2852.0
12661.0	3803.0
13628.0	3883.0
16082.0	4754.0
17194.0	5705.0

Figure 4-4: HEC-HMS Modified Puls Routing Reach Window

CHAPTER 4: HYDROLOGY

HEC-HMS modeling input for the Muskingum-Cunge Standard method consists of the following physical parameters: the length and slope of the routing reach, the Manning's roughness coefficient (n value), the shape of the channel (circular or prismatic), the bottom width or diameter, and the side slope ratio. This mathematical routing method provides an implicit accounting of storage within the channel. However, storage within the flood plain outside the defined channel is not considered. Although the same equations and solution techniques are used for the Muskingum-Cunge 8-Point method, the channel is described with eight station-elevation coordinates instead of a standard cross-section shape. Other required input items for this method are the reach length, energy slope, and n values for the channel and overbanks. For additional information on these routing methods, refer to the HEC-HMS documentation listed in Section 4.2.

4.2.9 Combining Hydrographs

When analyzing Basins or subbasins that have been divided into two or more sub-areas, it is necessary to combine runoff hydrographs from the individual sub-areas. Combining the hydrographs yields a single hydrograph, which accounts for all the runoff from the individual sub-areas. This is accomplished by inserting a junction in the HEC-HMS Basin Model. Connect the two sub-areas to the junction to obtain a combined hydrograph as shown in Figure 4-5. In this figure, HEC-HMS will compute individual hydrographs for Subbasin-1 and Subbasin-2 and combine them at Junction-1.

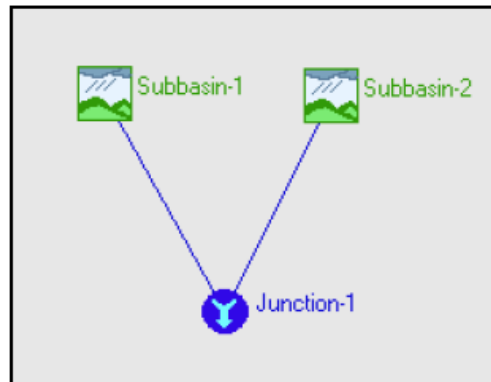
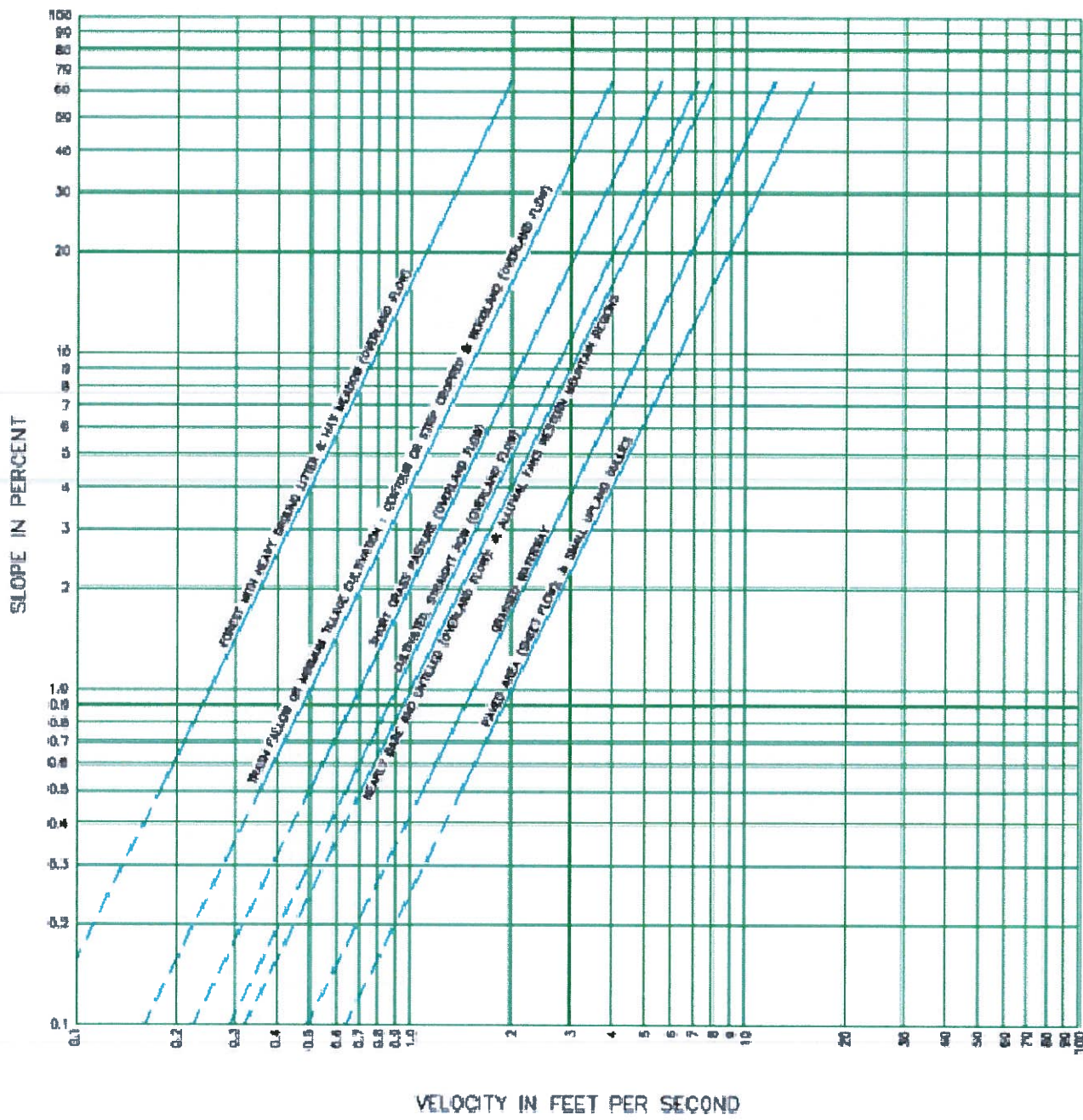

Figure 4-5: HEC-HMS Hydrograph Combining Schematic



SCS UPLANDS METHOD



DRAINAGE
CRITERIA
MANUAL

EXHIBIT #: 4-1
DATE: SEPTEMBER 2018

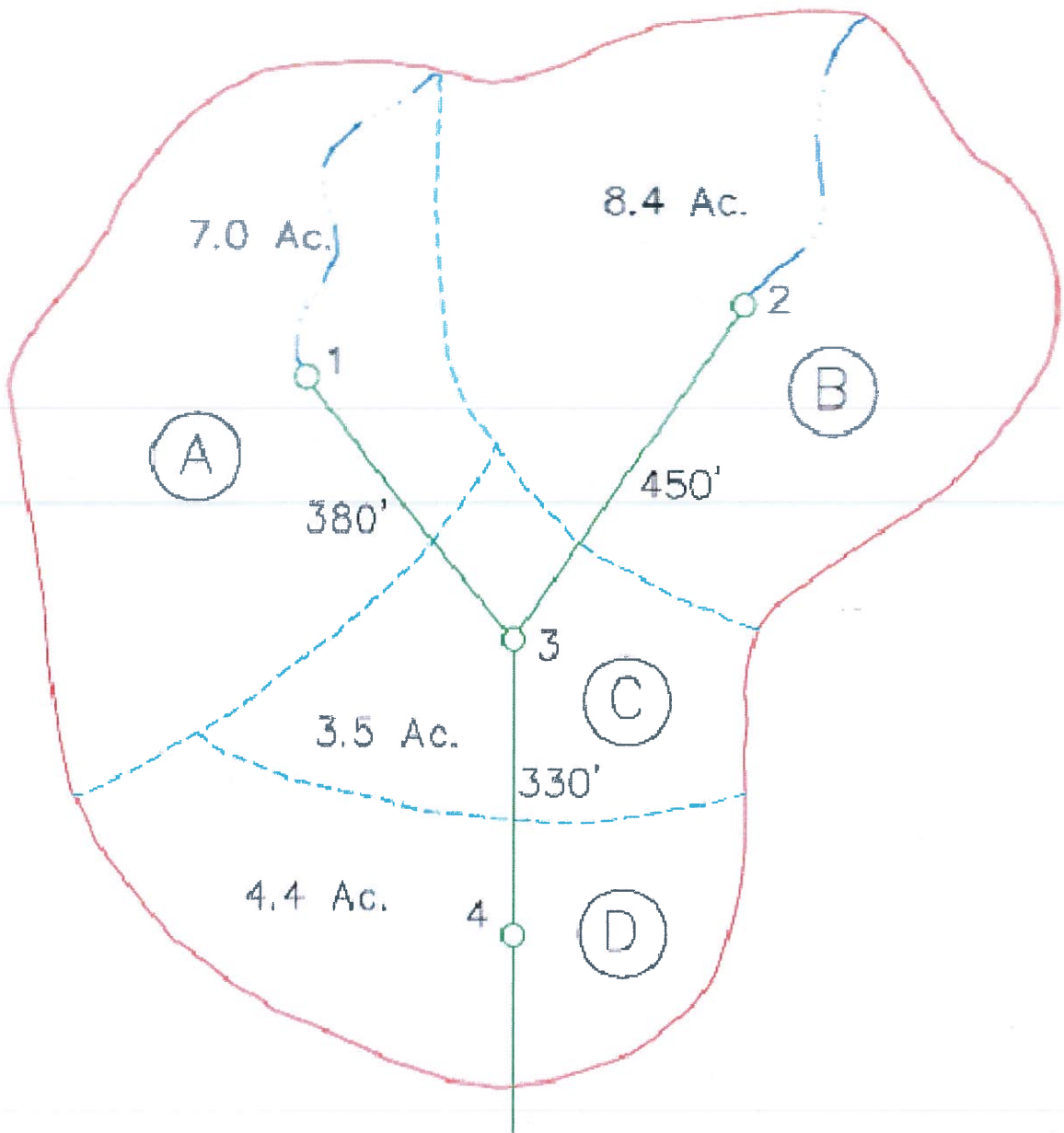

WATERSHED WITH
MULTIPLE SUB-AREAS



DRAINAGE
CRITERIA
MANUAL

EXHIBIT #: 4-2

DATE: SEPTEMBER 2018

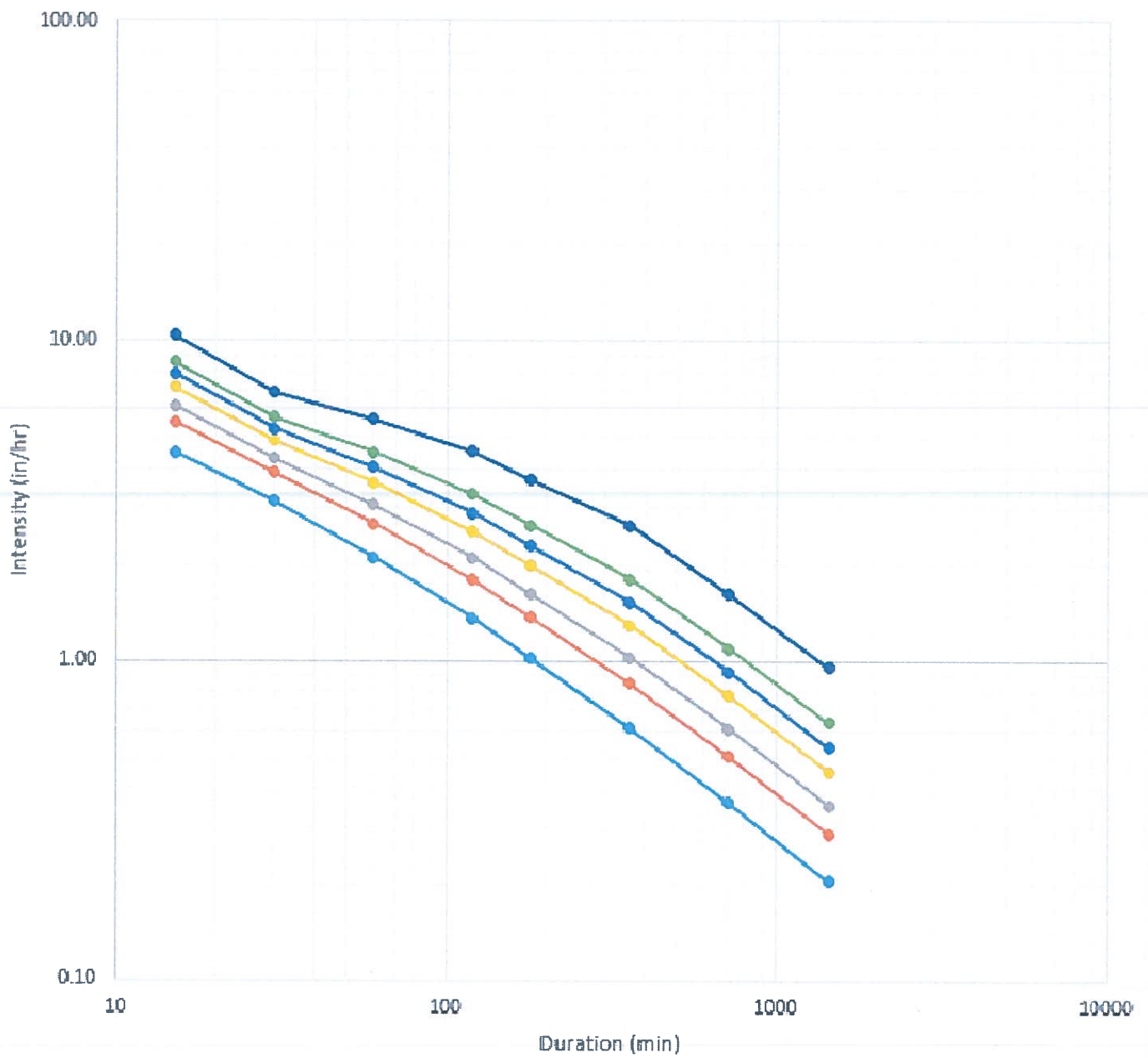

● 2-yr
 ● 5-yr
 ● 10-yr
 ● 25-yr
 ● 50-yr
 ● 100-yr
 ● 500-yr

USGS WRIR 98-4044
IDF CURVES FOR JEFFERSON COUNTY



DRAINAGE
CRITERIA
MANUAL

EXHIBIT #: 4-3
DATE: SEPTEMBER 2018

5. HYDRAULICS OF PRIMARY DRAINAGE FACILITIES

The purpose of this chapter is to provide detailed information on the hydraulic analysis and design of primary drainage facilities within DD7's boundaries. As indicated in Chapter 1, the primary drainage facilities include open channels, bridges, culverts, and enclosed drainage systems (i.e., open channels that have been enclosed).

5.1 GENERAL DESIGN REQUIREMENTS FOR PRIMARY DRAINAGE FACILITIES

The following design requirements are discussed in this section: design storm frequencies; design requirements for earthen channels; design requirements for concrete-lined channels; design requirements for rectangular concrete low-flow sections; transitions, bends, and confluences; design requirements for culverts; structural requirements for culverts; design requirements for bridges; design requirements for enclosed systems; and maximum allowable velocities.

5.1.1 Design Storm Frequencies

The following design storm frequencies shall be used for analysis and design of open channels, bridges, culverts, and enclosed systems:

- Channels draining up to 100 acres shall be designed to convey 25-year peak discharges with a minimum freeboard of one foot.
- Channels draining between 100 acres and 200 acres shall be designed to convey 50-year peak flow rates a minimum freeboard of one foot.
- Channels draining greater than 200 acres shall be designed to convey 100-year peak flow rates a minimum freeboard of one foot. These channels shall also be analyzed using a 10-year design storm event.
- For open channel studies involving *Federal Emergency Management Agency (FEMA)* submittals, the 10-year, 50-year, 100-year, and 500-year storm frequencies must be analyzed.

5.1.2 Design Requirements for Earthen Channels

The following minimum requirements shall be incorporated into designs of earthen channels:

- Channel side slopes shall be no steeper than 3 horizontal to 1 vertical (3:1). Flatter slopes may be required when soil conditions are conducive to slope instability.
- The minimum channel bottom width shall be six feet.
- A maintenance berm is required on both sides of the channel. For channels with top widths of 30 feet or less, the minimum maintenance berm width is 15 feet. For top widths between 30 feet and 60 feet, 20-foot maintenance berms are required. For channels with top widths greater than 60 feet, the minimum maintenance berm width is 30 feet. Additional width shall be provided to accommodate backslope swales if necessary.
- Backslope drain swales and interceptor structures are required to prevent flow down the ditch side slopes. The maximum spacing for interceptor structures is 600 feet.

- Channels, channel rights-of-way (ROWs) and side slopes must be vegetated immediately after construction to minimize erosion in accordance with the erosion control requirements discussed in Chapter 8.
- Flow from roadside ditches must be conveyed into open channels through standard roadside ditch interceptor structures as described in Chapter 8.
- A geotechnical investigation and report on local soil conditions is required for all channel construction and improvement projects.

Exhibit 5-1 illustrates a typical design cross-section for a trapezoidal earthen channel.

5.1.3 Minimum Design Requirements for Trapezoidal Concrete-Lined Channels

Concrete-lined channels shall be designed to meet the following minimum requirements:

- All concrete slope paving shall consist of Class A concrete.
- The minimum bottom width shall be eight feet.
- The side slopes of the channel shall be no steeper than 1.5 horizontal to 1 vertical (1.5:1).
- A maintenance berm is required on both sides of the channel. The berm width shall be at least 20 feet on one side of the channel and at least 15 feet on the other side.
- All slope paving shall include a toe wall at the top and sides with a minimum depth of 18 inches. Toe walls shall also be included along the bottom of the channel with a minimum depth of 24 inches for clay soils and 36 inches for sandy soils.
- Backslope drain swales and interceptor structures are required in the channel maintenance berm to prevent overland flow down the bank of partially-lined channels. These items shall be designed in accordance with the minimum requirements specified in Chapter 8. However, backslope drain swales and interceptor structures are not required on fully lined channels.
- Channel maintenance berms must be vegetated immediately after construction in accordance with erosion control requirements discussed in Chapter 8.
- Weep holes shall be used to relieve hydrostatic pressure behind lined channel sections. The specific type, size, and placement of the weep holes shall be based on the recommendations of the geotechnical report.
- Where construction is to take place under muddy conditions or where standing water is present, a seal slab of Class C concrete shall be placed in the channel bottom prior to placement of the concrete slope paving.
- Control joints shall be provided at a maximum spacing of approximately 25 feet. A sealing agent shall be utilized to prevent moisture infiltration at control joints.
- Concrete slope protection shall have the minimum thickness and reinforcement indicated in Table 5-1.
- A geotechnical investigation and report on local soil conditions is required for all channel construction and improvement projects.

Exhibit 5-2 illustrates a typical design cross-section for a trapezoidal concrete-lined channel.

TABLE 5-1: MINIMUM THICKNESS AND REINFORCEMENT FOR CONCRETE SLOPE PAVING			
Channel Side Slope (H:V)	Minimum Thickness (inches)	Minimum Reinforcement	
		Material	Dimensions
3:1	4 inches	welded wire fabric	6 x 6 x W2.9 x W2.9
2:1	5 inches	welded wire fabric	6 x 6 x W4.0 x W4.0
1.5:1	6 inches	reinforcement	4 x 4 x W4.0 x W4.0

5.1.4 Design Requirements for Rectangular Concrete Low-Flow Sections

As shown on Exhibit 5-3, rectangular concrete low-flow sections can be incorporated into designs for earthen and concrete-lined channels to provide additional capacity or depth in areas where channel ROW is limited. The following criteria shall be used for concrete low-flow sections:

- All concrete slope paving shall consist of Class A concrete.
- The structural steel design should be based on the use of ASTM A-615, Grade 60 steel.
- The minimum bottom width of the low-flow section shall be eight feet.
- For bottom widths of 12 feet or more, the channel bottom shall be graded toward the centerline at a slope of 1/2 inch per foot (4.15-percent).
- The maximum height of vertical concrete walls shall be three (3) feet.
- Escape stairways shall be located at the upstream side of all roadway crossings. Additional escape stairways shall be located along the channel to keep the maximum distance between stairways below 1,400 feet between stairways.
- For channels with concrete low-flow sections, the top of the vertical concrete wall shall be constructed in such a way as to provide for the possible future placement of concrete slope paving.
- Weep holes shall be used to relieve hydrostatic pressure behind lined channel sections. The specific type, size, and placement of the weep holes shall be based on the recommendations of the geotechnical report.
- Where construction is to take place under muddy conditions or where standing water is present, a seal slab of Class C concrete shall be placed in the channel bottom prior to placement of the concrete slope paving.

- Control joints shall be provided at a maximum spacing of approximately 25 feet. A sealing agent shall be utilized to prevent moisture infiltration at control joints.
- Concrete low-flow channels may be used in combination with a maintenance shelf on one or both sides of the channel. The minimum width of the shelf shall be fourteen 14 feet. Pavement used on the shelf shall be capable of supporting maintenance equipment having a concentrated wheel load of at least 1,350 pounds.
- All designs of concrete low-flow sections shall be supported by structural computations.
- A geotechnical investigation and report on local soil conditions is required for all channel construction and improvement projects.

5.1.5 Design Requirements for Transitions, Bends, and Confluences

Transitions, bends, and confluences shall be designed to meet the following minimum requirements:

- Transitions in channel bottom widths or side slopes shall be designed to create minimal flow disturbance and thus minimal energy loss. Transition angles should be less than 12 degrees.
- A warped or wedge-type transition is recommended for connecting rectangular and trapezoidal channel sections.
- Channel bends shall be made as gradually as possible. The minimum bend radius along the centerline of the channel is three times the top width of the channel at the maximum design water surface elevation (WSEL). Where smaller radii are required, erosion protection (i.e., concrete slope paving, riprap, interlocking blocks, etc.) is required as specified in Chapter 8. In no case shall the bend radius be less than 100 feet.
- The maximum allowable deflection angle for any bend in an improved channel is 90 degrees.
- Erosion protection shall be provided at channel confluences in accordance with the erosion protection requirements described in Chapter 8.

5.1.6 Design Requirements for Culverts

- Culverts shall be designed to convey the fully developed peak discharge rates associated with the design storm frequency requirements provided in Section 5.1.1 while maintaining a minimum freeboard of one-foot in the channel upstream of the culvert. In addition, the maximum allowable velocities discussed in Section 5.1.10 must not be exceeded.
- Culverts shall be aligned parallel to the longitudinal axis of the channel to maximize hydraulic efficiency and minimize turbulence and erosion. At locations where a difference between the alignment of the channel and the culvert is necessary, the change in alignment shall be accomplished upstream of the culvert so that the culvert is aligned with the downstream channel.
- The minimum allowable diameter for circular culverts is 24 inches.
- The minimum allowable size of box culverts is two feet x two feet.

- Concrete slope paving or riprap shall be used upstream and downstream of the culvert to protect earthen channels from erosion.
- Culverts shall extend completely across road and railroad ROWs at crossing locations.
- Where hydraulic jumps are anticipated around culverts, the channel geometry shall be modified to force the hydraulic jump to occur in a portion of the channel protected with concrete slope paving. Hydraulic jumps are characterized by a rapid change in the depth of flow from a low stage to a high stage, which results in an abrupt rise in the WSEL.

5.1.7 Structural Requirements for Culverts

Unless otherwise approved, all pipe and box culverts shall satisfy the following minimum structural design requirements:

- All pre-cast reinforced concrete pipe shall be ASTM C-76.
- All high density polyethylene (HDPE) pipe culverts shall conform to the AASHTO M294 specifications. Bedding for HDPE culverts shall be designed and constructed in accordance with the manufacturer's recommendations.
- All pre-cast reinforced concrete box culverts with more than two feet of earthen cover shall be ASTM C789-79. All pre-cast reinforced box culverts with less than two feet of earthen cover shall be ASTM 850-79.
- All corrugated steel pipes shall be aluminized in accordance with AASHTO M-36.
- AASHTO HS20-44 loading shall be used for all culverts.
- Joint sealing materials for pre-cast concrete culverts shall comply with the "AASHTO Designation M-198 74 I, Type B, Flexible Plastic Gasket (Bitumen)" specification.
- Two-sack-per-ton cement-stabilized sand shall be used for backfill around culverts.
- A six-inch bedding of two-sack-per-ton cement-stabilized sand is required for all pre-cast concrete box culverts.

5.1.8 Design Requirements for Bridges

Bridges shall be designed to meet the following requirements:

- Bridges shall be designed to convey the fully developed peak discharge rates associated with the design storm frequency requirements provided in Section 5.1.1 while maintaining a minimum freeboard of one-foot in the channel upstream of the bridge. In addition, the maximum allowable velocities discussed in Section 5.1.10 must not be exceeded.
- New bridges shall be designed to completely span the existing or proposed channel so that the channel will pass under the bridge without significant contractions or changes in the channel shape. Bridges constructed on existing or interim channels shall be designed to accommodate the ultimate channel section with minimum structural modifications.
- Bridges shall be designed to intersect the channel at an angle of 90 degrees, if possible.
- Pier bents and abutments shall be aligned parallel to the direction of flow in the channel. Pier bents shall be placed as far from the center of the channel as possible and wherever possible shall be placed within the channel side slopes instead of the channel bottom.
- Concrete slope paving or riprap shall be used to protect earthen channels from erosion underneath, upstream and downstream of bridges.
- Where hydraulic jumps are anticipated around bridges, the channel geometry shall be modified to force the hydraulic jump to occur in a portion of the channel protected with concrete slope paving.

5.1.9 Enclosed Drainage Systems

Enclosed drainage systems include pipe and box culverts used to replace segments of open channel longer than the typical width of a road or railroad ROW.

- Enclosed drainage systems shall be designed to accommodate fully developed design peak runoff rates discussed in Section 5.1.1 while maintaining the hydraulic grade line elevations below adjacent natural ground elevations or street gutter elevations, whichever are lower for fully-developed watershed conditions.
- The minimum inside pipe dimension shall be two feet.
- The minimum and maximum allowable velocities for design peak runoff rates shall be two feet per second and eight feet per second, respectively, assuming full pipe flow.
- Structural requirements for enclosed systems are identical to those specified for pipe and box culverts in Section 5.1.7.
- Manholes or junction boxes shall be located no more than 600 feet apart along the entire length of the system and at all locations where changes in culvert size and shape occur.
- Outfall structures shall conform to the requirements set forth for storm sewer outfalls in Chapter 7 of this manual.
- The ROW width required for enclosed systems will be set equal to the maximum pipe or box width plus two times the depth to the culvert invert or 30 feet, whichever is smaller.

5.1.10 Maximum Flow Velocities

The maximum allowable velocity in open channels and at bridges or culverts shall be analyzed for the design storm event. As shown in Table 5-2, the maximum allowable velocity is related to the type of channel, the slope treatment, and the soil structure throughout the open channel section. If the maximum velocities listed in this table are exceeded during the design storm event, then the channel design shall be modified until acceptable velocities are attained. Alternatively, erosion protection (i.e., riprap, concrete slope paving, or interlocking blocks) could be provided to increase the maximum allowable velocity in that portion of the channel (see Chapter 8). However, the erosion protection must extend upstream and downstream a sufficient distance to a location where the design storm velocity in the channel is below the maximum allowable levels for earthen channels without slope protection.

TABLE 5-2: MAXIMUM ALLOWABLE VELOCITIES IN OPEN CHANNELS		
Soil Description	Slope Treatment	Maximum Velocity (feet per second)
Fine Sand	None	1.50
Sandy Loam	None	1.75
Silt Loam	None	2.00
Clay Loam	None	2.50
Stiff Clay	None	3.75
Sandy Soils (Easily Eroded)	Grass	4.00
Clay Soils (Erosion-Resistant)	Grass	5.00
Sandy Soils (Easily Eroded)	Rip-Rap	6.00
Clay Soils (Erosion Resistant)	Rip-Rap	8.00
Sandy Soils (Easily Eroded)	Concrete	8.00
Clay Soils (Erosion Resistant)	Concrete	10.00
Bridges & Culverts		8.00

5.1.11 Maintenance

Provisions for adequate maintenance must be made in the design of all drainage facilities. Sufficient ROW must be set aside, slopes must be kept at or below maximum values, and slope treatments must be properly completed. Access to drainage facilities must not be impeded.

5.2 HYDRAULIC ANALYSIS OF PRIMARY DRAINAGE FACILITIES

This section describes the methods to be used in the hydraulic analysis of open channels as well as associated bridge and culvert structures.

5.2.1 Acceptable Open Channel Design Methodologies

The final open channel dimensions shall be determined by using the *HEC-RAS* computer program developed at the Hydrologic Engineering Center of the U.S. Army Corps of Engineers (USACE). The latest version of this software program can be downloaded from the USACE's website (<http://www.hec.usace.army.mil/software/hecras/hecras-download.html>) at no charge. The HEC-RAS program has the capability to analyze unsteady flow conditions, transitions from subcritical to supercritical flow, and other complex hydraulic conditions.

The hydraulic data discussed in Sections 5.2.1 to 5.2.8 should be compiled to facilitate development of HEC-RAS models. Additional information on HEC-RAS can be obtained from the *HEC-RAS River Analysis System User's Manual*, the *HEC-RAS River Analysis System Application's Guide*, and the *HEC-RAS River Analysis System Hydraulic Reference Manual* developed by the USACE. All of these manuals can be downloaded free of cost from the USACE's website at <http://www.hec.usace.army.mil/software/hecras/hecras-document.html>.

5.2.2 Acceptable Bridge and Culvert Design Methodologies

Hydraulic analysis of bridges and culverts may be performed using the HEC-RAS computer program. However, the nomographs developed by the Federal Highway Administration (FHWA) published in *Hydraulic Design of Highway Culverts* may be used for initial estimates of culvert size or to verify that the results obtained from HEC-RAS are reasonable. These nomographs can also be used to size culverts associated with roadside ditches. In addition, any other software programs which meet industry standards can be used, if prior approval is obtained from DD7.

5.2.3 Acceptable Enclosed Drainage System Design Methodologies

Hydraulic analysis of enclosed drainage systems that are part of an open channel system may be analyzed using HEC-RAS. In addition, any other software programs which meet industry standards can be used, if prior approval is obtained from the DD7. For stand-alone enclosed systems, the methodology described in Chapter 6 for storm sewer systems shall be used. For these calculations, full pipe flow may be assumed. Both friction losses and minor losses (i.e., losses due to transitions, bends, junctions, manholes, etc.) should be accounted for.

5.2.4 Flow Data

The Rational Method may be used to compute the peak flow rates for drainage areas up to 200 acres. However, a HEC-HMS hydrologic analysis can also be performed for drainage areas up to 200 acres. For drainage areas greater than 200 acres, the HEC-HMS methodology discussed in Chapter 4 shall be used to compute peak discharge rates for the design storm frequencies specified in Section 5.1.1. These peak flow rates shall be used to develop the flow data in HEC-RAS.

For an unsteady flow analysis, the inflow hydrographs computed in HEC-HMS are used instead of peak discharge rates. These hydrographs should be entered into the Unsteady Flow Data editor of HEC-RAS for unsteady flow detention analyses (see Chapter 7) or the applicable portion of other approved software programs.

5.2.5 Boundary Conditions

In order for HEC-RAS to perform computations, boundary conditions or starting WSELs must be defined. Boundary conditions are required at the downstream and upstream ends of the river system for subcritical and supercritical flow regimes, respectively. For mixed flow regimes, boundary conditions are required at both the upstream and downstream ends of the system. Subcritical flow typically occurs in the Jefferson County DD7 area. This flow regime has a low velocity and appears tranquil, whereas the supercritical flow regime is characterized by shooting and rapid flows.

For unsteady flow detention analyses (see Chapter 7), a variety of boundary conditions are available within the Unsteady Flow Data editor. Refer to the *HEC-RAS River Analysis System User's Manual* for additional information on the available unsteady flow boundary conditions. For open channel analyses, the downstream boundary conditions should be entered into the Steady Flow Data editor. If a HEC-RAS model of the receiving channel is not available, then normal depth should be used as the downstream boundary condition and the energy slope should be entered. The energy slope can be approximated as the slope of the bottom of the channel. If a HEC-RAS model of the receiving channel is available and the tailwater in this channel can be determined, then the known WSEL downstream boundary condition should be selected.

In order to determine the tailwater elevation in the receiving channel, the Frequencies of Coincidental Occurrence methodology described in the Texas Department of Transportation's (TxDOT's) *Hydraulic Design Manual* shall be used. This methodology is based on the assumption that the rainfall events within the drainage system being analyzed and the receiving channel are neither completely dependent nor completely independent. As shown in Table 5-3, this method provides a basis for selecting an appropriate frequency for the tailwater elevation of the receiving channel versus the frequency for the tributary channel, storm sewer system, or *detention basin*. For example, a 100-year analysis of a tributary channel with a drainage area of 200 acres that discharges to an open channel with an associated drainage area of 2,000 acres would have a ratio of receiving channel to tributary of 10:1. Therefore, the required tailwater elevation for the 100-year analysis of the tributary channel would be the 50-year WSEL in the receiving channel.

Area Ratio	Design Storm Event for the Hydraulic Analysis of Tributary Channels, Storm Sewer Systems, or Detention Basins					
	2-year	5-year	10-year	25-year	50-year	100-year
10,000:1	2	2	2	2	2	2
1,000:1	2	2	2	5	5	10
100:1	2	2	5	10	10	25
10:1	2	5	10	10	25	50
1:1	2	5	10	25	50	100

5.2.6 Cross-Section Data

The cross-section data required by HEC-RAS includes: elevation-station data; Manning’s roughness coefficients (n values), which are described in Section 5.2.7; channel and overbank reach lengths; top of bank (TOB) locations; and expansion and contraction coefficients. If ineffective flow areas (IFAs), levees, or blocked obstructions exist, then geometric information regarding these items would also be entered in the Cross-Section Data Editor.

The elevation-station data shall be obtained from recent field survey data and the cross-sections shall be extended far enough into the left and right overbanks so that all of the flow is contained within the defined cross-section, if possible. Although LIDAR data may be used to supplement field survey data and define the overbank areas of the cross-sections, field survey data is required to accurately define the channel because LIDAR does not penetrate water. Cross-sections shall be taken approximately every 500 feet along the channel, unless project-specific considerations warrant otherwise. In the vicinity of bridges and culverts, cross-section spacing shall adhere to recommendations in the HEC-RAS program documentation referenced in Section 5.2.1. If necessary, additional cross-sections can be interpolated by HEC-RAS or field surveyed cross-sections can be copied to achieve the required cross-section spacing around bridges and culverts.

Channel reach lengths between cross-sections shall be measured along the centerline of the channel. As indicated in the *HEC-RAS River Analysis System Hydraulic Reference Manual*, left and right overbank lengths should be determined as the length along the anticipated path of the center of mass of overbank flow. In many instances, all three reach length values will be similar. However, they may differ significantly at channel bends and locations where the channel meanders while the overbanks remain straight.

For the Jefferson County DD7 area, the typical expansion and contraction coefficients for open channels are 0.1 and 0.3, respectively. However, higher coefficients of 0.3 and 0.5 should be used at cross-sections two, three, and four around bridges and culverts to simulate expansion and contraction conditions around these structures. Refer to the *HEC-RAS River Analysis System User’s Manual* for information on the location of cross-sections two through four around bridges and culverts. IFAs should also be included around bridges and culverts using the recommendations outlined in the *HEC-RAS River Analysis System Hydraulic Reference Manual*.

HEC-GeoRAS can be used to automate the development of HEC-RAS models by importing channel geometric data directly into HEC-RAS. The channel centerline location, cross-section data, reach lengths, assumed TOB locations, n values, and expansion/contraction coefficients can be defined within HEC-GeoRAS and imported directly into HEC-RAS. However, this program requires input from an engineer or hydrologist experienced with hydraulic modeling. In addition, TOB locations and overbank reach lengths may need to be modified within HEC-RAS. IFAs, levees, and blocked obstructions would also need to be entered directly into HEC-RAS.

5.2.7 Manning's Roughness Coefficient

The HEC-RAS software program utilizes Manning's Equation, which is discussed in Chapter 3, to compute conveyance and flows in open channels. The n value used in this equation varies inversely with conveyance and is a measure of the roughness of the surfaces with which storm water comes into contact. For example, a forested area would have a higher n value and a lower conveyance than a pasture or open field. Recent aerial photographs as well as field reconnaissance can be used in conjunction with Table 5-4 to determine n values for channels and flood plains, or overbank areas.

Although Table 5-4 is generally adequate for selecting n values corresponding to existing field conditions, project-specific considerations may warrant the use of Equation 5-1 for a more detailed determination of n values associated with the channel and flood plains (overbanks). For most applications, it is acceptable to round n values to the nearest 0.005 (i.e., an n value of 0.033 would be entered into HEC-RAS as 0.035).

$$n = (n_0 + n_1 + n_2 + n_3 + n_4)m \quad \text{Equation 5-1}$$

- where: n = composite Manning's roughness coefficient;
 n_0 = base value for the bare soil surface material of the channel or flood plain;
 n_1 = value to correct for the irregularity of the channel or flood plain;
 n_2 = value to account for variations in the shape and size of the channel or flood plain cross-section;
 n_3 = value to account for obstructions in the channel or flood plain;
 n_4 = value to account for the effects of vegetation;
 m = correction factor for the sinuosity of the channel or flood plain.

Tables 5-5 and 5-6 provide a summary of parameters used in Equation 5-1 to compute n values for channels and flood plains, respectively.

TABLE 5-4: MANNING'S ROUGHNESS COEFFICIENTS

Type of Channel and Description	Minimum	Normal	Maximum
<i>Excavated or Dredged Channels</i>			
Concrete Lined Channels	0.011	0.013	0.015
Earthen Channels, Straight and Uniform			
<i>Clean, After Weathering</i>	0.016	0.018	0.020
<i>With Short Grass, Few Weeds</i>	0.022	0.027	0.033
Earthen Channels, Winding and Sluggish			
<i>No Vegetation</i>	0.023	0.025	0.030
<i>Grass, Some Weeds</i>	0.025	0.030	0.033
<i>Dense Weeds or Plants in Deep Channels</i>	0.030	0.035	0.040
<i>Earth Bottom and Rubble Sides</i>	0.028	0.030	0.035
<i>Stony Bottom and Weedy Banks</i>	0.025	0.035	0.040
<i>Cobble Bottom and Clean Sides</i>	0.030	0.040	0.050
Channel Not Maintained, Weeds & Brush Uncut			
<i>Dense Weeds, High as Flow Depth</i>	0.050	0.080	0.120
<i>Clean Bottom, Brush on Sides</i>	0.040	0.050	0.080
<i>Same, Highest Stage of Flow</i>	0.045	0.070	0.110
<i>Dense Brush, High Stage</i>	0.080	0.100	0.140
<i>Natural Streams</i>			
Clean, Straight, Full Stage, No Rifts or Deep Pools	0.025	0.030	0.033
Same as Above, But Some Stones and Weeds	0.030	0.035	0.040
Clean, Winding, Some Pools and Shoals	0.033	0.040	0.045
Same as Above, But Some Weeds and Stones	0.035	0.045	0.050
Same as Above, Lower Stages, More Ineffective Areas	0.040	0.048	0.055
Sluggish Reaches, Weedy, Deep Pools	0.050	0.070	0.080
<i>Flood Plains</i>			
Pasture, No Brush			
<i>Short Grass</i>	0.025	0.030	0.035
<i>High Grass</i>	0.030	0.035	0.050
Cultivated Areas			
<i>No Crop</i>	0.020	0.030	0.040
<i>Mature Row Crops</i>	0.025	0.035	0.045
<i>Mature Field Crops</i>	0.030	0.040	0.050
Brush			
<i>Scattered Brush, Heavy Weeds</i>	0.035	0.050	0.070
<i>Light Brush and Trees, in Winter</i>	0.035	0.050	0.060
<i>Light Brush and Trees, in Summer</i>	0.040	0.060	0.080
<i>Medium to Dense Brush, in Winter</i>	0.045	0.070	0.110
<i>Medium to Dense Brush, in Summer</i>	0.070	0.100	0.160
Trees			
<i>Dense Willows, Summer, Straight</i>	0.110	0.150	0.200
<i>Cleared Land with Stumps, No Sprouts</i>	0.030	0.040	0.050
<i>Same as Above with Heavy Growth of Sprouts</i>	0.050	0.060	0.080
<i>Heavy Stand of Timber, a Few Down Trees, Little Undergrowth, Flood Stage Below Branches</i>	0.080	0.100	0.120
<i>Same as Above, but with Flood Stage Reaching Branches</i>	0.100	0.120	0.160

TABLE 5-5: PARAMETERS USED IN COMPUTING CHANNEL ROUGHNESS COEFFICIENTS

Parameter	Accounts For	Representative Roughness Values
n ₀	Channel Material	0.011 for Concrete 0.020 for Earth 0.025 for Rock Cut 0.024 for Fine Gravel 0.028 for Coarse Gravel
n ₁	Degree of Irregularity	0.000 for Smooth 0.005 for Minor Irregularities 0.010 for Moderate Irregularities 0.020 for Severe Irregularities
n ₂	Variation of Channel Cross-Section	0.000 for Gradual Variations 0.005 for Alternating Occasionally 0.010 to 0.015 for Alternating Frequently
n ₃	Relative Effect of Obstructions	0.000 for Negligible Obstructions 0.010 to 0.015 for Minor Obstructions 0.020 to 0.030 for Appreciable Obstructions 0.040 to 0.060 for Severe Obstructions
n ₄	Vegetation	0.005 to 0.010 for Low Vegetation 0.010 to 0.025 for Medium Vegetation 0.025 to 0.050 for High Vegetation 0.050 to 0.100 for Very High Vegetation
m	Degree of Meandering	1.000 for Minor Meandering 1.150 for Appreciable Meandering 1.300 for Severe Meandering

**TABLE 5-6: PARAMETERS USED IN COMPUTING FLOOD PLAIN
ROUGHNESS COEFFICIENTS**

Parameter	Accounts For	Representative Values
n_0	Base Material	0.010 for Concrete 0.020 for Earth 0.025 for Rock Cut 0.024 for Fine Gravel 0.028 for Coarse Gravel
n_1	Degree of Irregularity	0.000 for Smooth 0.001 to 0.005 for Minor Irregularities 0.006 to 0.010 for Moderate Irregularities 0.011 to 0.020 for Severe Irregularities
n_2	Variation in Cross-Section	0.000 Not Applicable
n_3	Effect of Obstructions	0.000 to 0.004 for Negligible Obstructions 0.005 to 0.019 for Minor Obstructions 0.020 to 0.030 for Appreciable Obstructions
n_4	Amount of Vegetation	0.001 to 0.010 for Small Amounts 0.011 to 0.025 for Medium Amounts 0.026 to 0.050 for Large Amounts 0.051 to 0.100 for Very Large Amounts 0.100 to 0.200 for Extreme Amounts
m	Degree of Meander	1.00 Not Applicable

5.2.8 Bridge & Culvert Data

HEC-RAS requires the following data for bridge and culvert computations: deck/roadway data, geometric data for culverts, sloping abutments and pier data for bridges, and the bridge or culvert modeling approach. Detailed information on all of the HEC-RAS data entry requirements is included in the HEC-RAS program documentation listed in Section 5.2.1. The following data is required to define the deck/roadway within the Deck/Roadway Data Editor: the distance between the upstream side of the bridge/culvert and the cross-section immediately upstream of the structure; the width of the bridge deck/culvert; upstream and downstream bridge deck/culvert station-elevation data; a weir coefficient, which ranges from 2.6 for flow over a bridge deck to 3.0 for flow over elevated roadway approach embankments; upstream and downstream embankment side slopes; the maximum allowable submergence before the program switches to energy based calculations rather than pressure and weir flow; the minimum weir flow elevation; and the weir crest shape.

The following culvert geometric data is entered into the Culvert Data Editor of HEC-RAS: solution criteria, culvert shape and size, culvert chart and scale numbers, distance to upstream cross-section, culvert length, entrance and exit loss coefficients, Manning's n values, upstream and downstream invert elevations, number of identical barrels, and centerline stations for each barrel. The highest upstream energy grade option should be selected for the culvert solution criteria. The Manning's

n value and entrance loss coefficients for the culvert(s) should be determined from Tables 5-7 and 5-8, respectively, and entered into the Culvert Data Editor. Typical exit loss coefficients for culverts range from 0.3 to 1.0, but are normally set at 1.0. Additional information on exit loss coefficients can be found in the *HEC-RAS River Analysis System Hydraulic Reference Manual*. A summary of the chart and scale numbers used by HEC-RAS for the FHWA culvert performance nomographs described in Section 5.2.2 is provided in Table 5-9. These FHWA nomographs are used as the basis for inlet control headwater computations in HEC-RAS. Field survey data and construction drawings should be used to determine the remaining culvert geometric data required by HEC-RAS.

TABLE 5-7: MANNING’S ROUGHNESS COEFFICIENTS FOR CULVERTS	
Description of Pipe	Roughness Coefficient (n)
Reinforced Concrete Pipe and Box Culverts	0.013
HDPE Plastic Pipe	0.012
Corrugated Steel Pipe With 2-2/3” x 1/2” Corrugations	0.024
Corrugated Steel Pipe With 3” x 1” Corrugations	0.027
Corrugated Steel Pipe With 6” x 2” Corrugations	0.030

TABLE 5-8: ENTRANCE LOSS COEFFICIENTS FOR CULVERTS

Type of Structure and Configuration of Entrance	Coefficient (K_e)
<i>Concrete Pipe Culverts</i>	
Projecting from Fill	
<i>Socket End (Groove End) of Pipe</i>	0.2
<i>Square-Cut End of Pipe</i>	0.5
Headwall or Headwall & Wingwalls	
<i>Socket End of Pipe (Groove End)</i>	0.2
<i>Square Edge</i>	0.5
Mitered to Conform to Fill Slope	0.7
End Section Conforming to Fill Slope	0.5
<i>Corrugated Steel Culverts</i>	
Projecting From Fill	0.9
Headwall or Headwall & Wingwalls	0.5
Mitered to Conform to Fill Slope	0.2
End Section Conforming to Fill Slope	0.5
<i>Concrete Box Culverts</i>	
Headwall Parallel to Embankment (No Wingwalls)	0.5
Wingwalls at 30 Degrees to 75 Degrees to Barrel	0.4
Wingwalls at 10 Degrees to 25 Degrees to Barrel	0.5
Wingwalls Parallel (Extensions of Sides)	0.7

TABLE 5-9: FHWA CHART AND SCALE NUMBERS FOR CULVERTS

Chart No.	Scale No.	Description of Culvert and Entrance Configuration
<i>Box Culverts with Flared Wingwalls</i>		
8	1	Wingwalls Flared 30 to 75 Degrees
	2	Wingwalls Flared 90 or 15 Degrees
	3	Wingwalls Flared 0 Degrees (Sides Extended Straight)
<i>Concrete Pipe Culverts</i>		
1	1	Square Edge Entrance with Headwall
	2	Groove End Entrance with Headwall
	3	Groove End Entrance, Pipe Projecting from Fill
<i>Corrugated Steel Culverts</i>		
2	1	Headwall
	2	Mitered to Conform to Fill Slope
	3	Pipe Projecting from Fill

Sloping abutment and pier data for bridges can be entered into the Sloping Abutment Data Editor and Pier Data Editor, respectively. The sloping abutment data requirements consist of station-elevation data, while the pier data requirements consist of elevation-width data as well as upstream and downstream centerline stations. The floating debris around a pier or piers can also be entered into the Pier Data Editor. In addition, the Bridge Design Editor within HEC-RAS can be used to facilitate the design of new bridges.

The Bridge Modeling Approach Editor requires the selection of low flow and high flow (pressure and/or weir) computation methods. Low flow occurs when water passes under a bridge or through a culvert without submerging the low chord of the bridge structure or the top of the culvert. Pressure flow occurs whenever the low chord of the bridge or the entire culvert is submerged and weir flow occurs when water overtops the roadway. Available low flow methods include: Energy (Standard Step), Momentum, Yarnell, and WSPRO. The Energy method should be selected for culvert analyses. Although a single low flow method may be selected for bridges, it is recommended that the Energy method as well as one or more other applicable methods be selected and that the highest energy answer be used. If the Momentum or Yarnell methods are selected for bridges, the user must enter a value for the pier loss coefficient that corresponds to that method. A list of representative coefficients can be obtained within the Bridge Modeling Approach Editor. If the WSPRO method is selected, the user must press the WSPRO Variables button and enter additional information that is required for that method. The available high flow methods are Energy (Standard Step) and Pressure and/or Weir. It is recommended that both of these methods be selected and that the highest energy answer be used.

5.2.9 Floodway Analysis

A floodway analysis is required if modifications are made to HEC-RAS models of streams that were studied by the Federal Emergency Management Agency (FEMA). As described in Chapter 5 and illustrated on Exhibit 5-4, the floodway is a corridor of effective flow that includes the channel and any adjacent land areas required to pass the 100-year peak discharge rates without increasing the WSEL at any point along the channel more than one-foot above the 100-year base flood elevations (BFE). The floodway is a regulatory concept that is intended to prevent encroachments (i.e., fill, structures, or other obstructions) from being placed too close to the channel without extensive analysis and mitigation measures. Additional information on FEMA requirements for floodway analysis can be obtained from FEMA's website (<http://www.fema.gov>), the HEC-RAS program documentation.

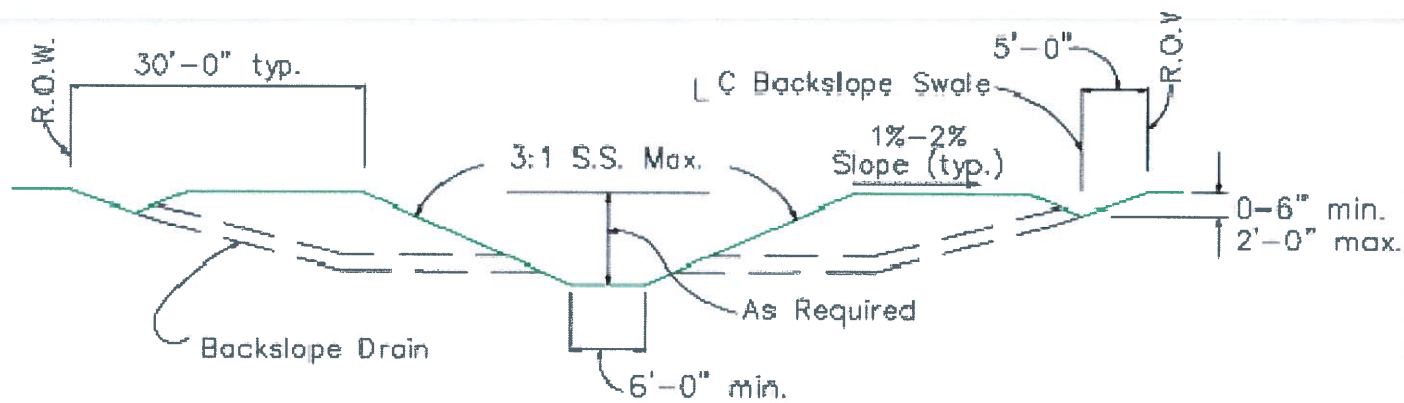

TYPICAL SECTION
GRASS-LINED TRAPEZOIDAL CHANNEL



DRAINAGE
CRITERIA
MANUAL

EXHIBIT #: 5-1

DATE: SEPTEMBER 2018

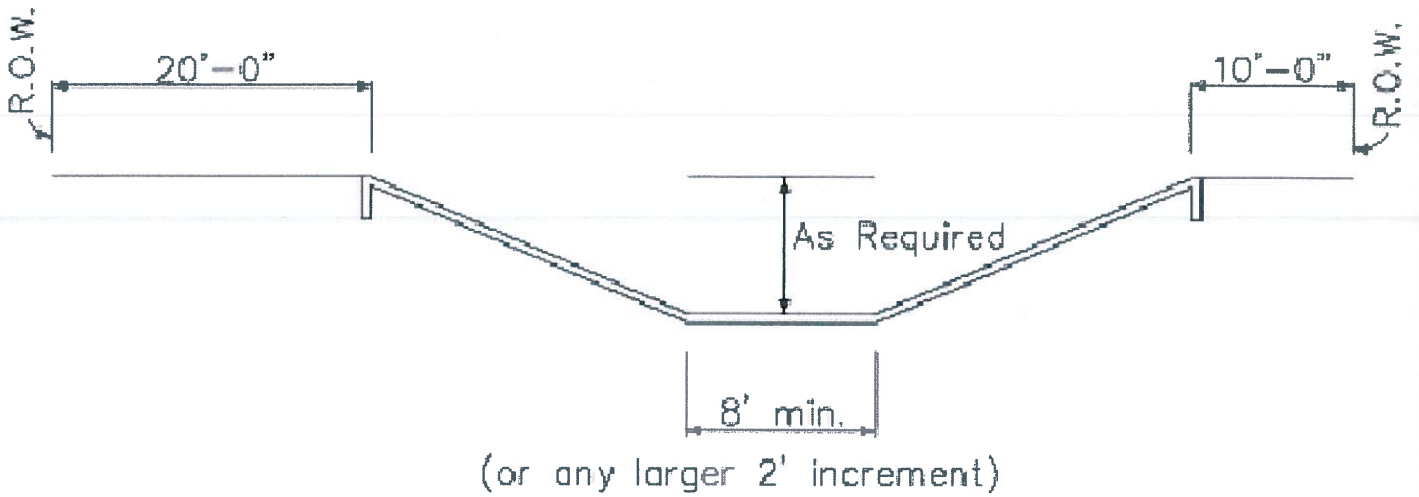

TYPICAL SECTION
CONCRETE-LINED TRAPEZOIDAL CHANNEL



DRAINAGE
CRITERIA
MANUAL

EXHIBIT #: 5-2

DATE: SEPTEMBER 2018

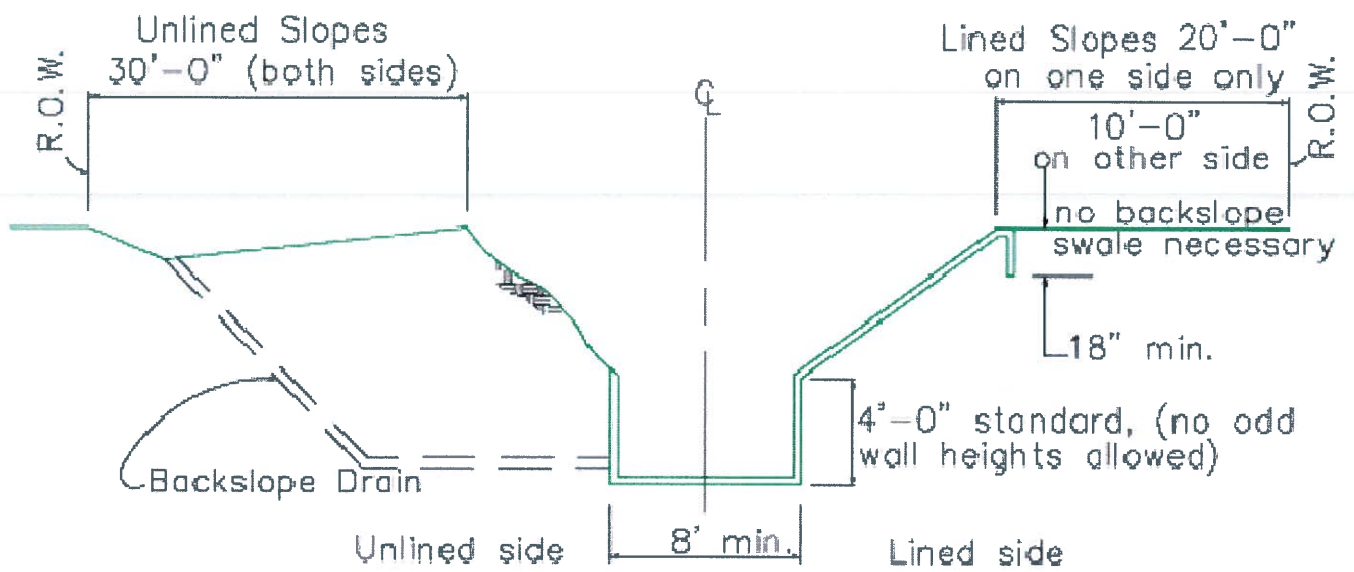

TYPICAL CROSS-SECTION, CONCRETE-LINED
WITH RECTANGULAR LOW-FLOW SECTION



DRAINAGE
CRITERIA
MANUAL

EXHIBIT #: 5-3

DATE: SEPTEMBER 2018

6. HYDRAULICS OF SECONDARY DRAINAGE FACILITIES

The purpose of this chapter is to provide detailed information on the hydraulic analysis and design of secondary drainage facilities within the boundaries of DD7. This chapter is for guidance purposes only. All municipal entities and the County within the DD7 service area maintain and enforce subdivision regulations which include drainage criteria. As stated elsewhere in this document and in the Drainage Regulations, “This manual is not intended to interfere with, abrogate, or annul any other ordinance, rule, or regulation, statute, or other provision of law.”

As indicated in Chapter 1, the secondary drainage facilities include storm sewers, sheet flow swales, and other facilities which typically serve relatively small drainage areas as well as lot grading and drainage requirements.

6.1 GENERAL DESIGN REQUIREMENTS FOR STORM SEWERS

This section describes the general design requirements for storm sewers, which include all conduit systems and may consist of either storm sewer pipes or box culverts. However, culverts and bridges within open channels shall be designed and analyzed using the criteria contained in Sections 5.1 and 5.2.

6.1.1 Design Storm Frequencies

The following design storm frequencies shall be used for analysis and design of storm sewers:

- Street gutters along residential streets should carry peak runoff rates from a five-year storm event without overtopping curbs while maintaining the hydraulic grade line (HGL) at an elevation below the gutter line at inlets and below the rim elevation at manholes. Major thoroughfares should accommodate five-year peak runoff rates with a minimum ten-foot dry travel lane and 25-year peak runoff rates without overtopping curbs.
- For systems draining less than 100 acres, storm sewers should be designed to convey five-year peak runoff rates while maintaining the HGL at an elevation below the gutter line at inlets and below the rim elevation at manholes. Peak 25-year runoff rates shall be accommodated with a maximum of six inches of flow depth above the crown of the roadway.
- For systems draining more than 100 acres but less than 200 acres, storm sewers should be designed to convey ten-year peak runoff rates while maintaining the HGL at an elevation below the gutter line at inlets and below the rim elevation at manholes. Peak 50-year runoff rates shall be accommodated with a maximum of six inches of flow depth above the crown of the roadway.
- For systems draining more than 200 acres, storm sewers should be designed to convey 25-year peak runoff rates while maintaining the HGL at an elevation below the gutter line at inlets and below the rim elevation at manholes. Peak 100-year runoff rates shall be accommodated with a maximum of six inches of flow depth above the crown of the roadway.

6.1.2 General Design Requirements

CHAPTER 6: HYDRAULICS OF SECONDARY DRAINAGE FACILITIES

- Storm sewer systems shall be designed to accommodate fully developed peak runoff rates associated with the design storm frequency requirements specified in Section 6.1.1 while maintaining the HGL at an elevation below the gutter line at inlets and below the rim elevation at manholes.
- The minimum and maximum allowable velocities for the design peak runoff rates are two feet per second and eight feet per second, respectively, assuming full pipe flow.
- The minimum allowable storm sewer pipe size is 18 inches.
- Manholes or junction boxes shall be placed where changes in pipe size, shape, and slope occur; at storm sewer junctions; and at intervals in long storm sewer segments where the size or direction has not changed.
- All storm sewers located within the public right-of-way (ROW) and/or easements should be constructed of reinforced concrete pipe (RCP). Other pipe materials in compliance with the DD7's adopted drainage criteria may be used for storm sewer systems.
- Structural requirements for storm sewer systems shall adhere to those specified for culverts in Section 5.1.7.
- Outfall structures shall conform to the requirements described in Section 8.5.
- Storm sewer outfalls shall be designed as illustrated on Exhibits 6-1 and 6-2.

6.1.3 Extreme Event Design

The capacity of the storm sewer system may be exceeded during rainfall events that are more intense than the design storm. For example, a storm sewer system designed to convey the five-year peak runoff rates from a drainage area will not have adequate capacity to convey the 100-year peak runoff rates from that area. As shown in Exhibit 6-3, ponding may occur in streets, roadside ditches, and adjacent low-lying areas when the capacity of the storm sewer system is exceeded. In order to eliminate or reduce potential flooding on adjacent properties, street layout and pavement grades shall be designed to direct storm water runoff into channels or drainage systems without flowing through private property. The street grading plan shall be developed to prevent 100-year ponding levels in the streets from exceeding the lowest of the following:

- one-foot above natural ground;
- one-foot over the top of curb;
- the lowest finished floor elevation of adjacent habitable structures and critical facilities.

Examples of undesirable and acceptable sheet flow patterns are illustrated in Exhibits 6-4 and 6-5, respectively. In areas where streets cannot be graded to carry sheet flows directly to an open channel, an extreme event overflow structure must be provided to collect sheet flow and convey it to a channel. This structure should consist of storm sewer and inlets designed to convey the 100-year peak runoff rate from the developed drainage area plus a grass- or concrete-lined emergency overflow swale located within a drainage easement between two residential lots.

6.2 HYDRAULIC ANALYSIS OF STORM SEWERS

This section describes the requirements for the hydraulic analysis of storm sewer systems.

6.2.1 Acceptable Storm Sewer Design Methods

Hydraulic analysis of storm sewers may be performed using manual calculations, a spreadsheet, or other storm sewer design methods approved by DD7. Intensity calculations for Rational Method analyses must utilize the Jefferson County *rainfall intensity* parameters shown in Table 4-3.

6.2.2 Peak Runoff Rates

The following methods shall be used to determine the peak runoff rates from the drainage area served by the storm sewer system:

- The Rational Method discussed in Chapter 4 may be used to determine peak runoff rates for storm sewer systems serving drainage areas up to 200 acres.
- The HEC-HMS methodology discussed in Chapter 4 shall be used to compute peak discharge rates for storm sewer systems serving drainage areas greater than 200 acres.

6.2.3 Storm Sewer Slopes

As indicated in Section 6.1.2, the minimum allowable velocity for storm sewers flowing full is two feet per second and the maximum allowable velocity for storm sewers flowing full is eight feet per second. Manning's equation (Equation 6-1) can be rearranged as indicated below to solve for the maximum and minimum pipe slopes required to maintain flow velocities within the acceptable range.

$$Q = \left(\frac{1.49}{n} \right) AR^{2/3} S^{1/2} \quad \text{Equation 6-1}$$

where: Q = flow rate (cubic feet per second);
 n = Manning's roughness coefficient from Table 5-4;
 A = cross-sectional area of flow, assuming full flow in pipe or box (square feet);
 R = hydraulic radius, cross-sectional area divided by wetted perimeter (feet);
 S = slope of the pipe or box (feet per foot).

As indicated in the Continuity Equation (Equation 6-2), the flow rate can be expressed as a function of velocity and area:

$$Q = V \times A \quad \text{Equation 6-2}$$

where: V = velocity (feet per second).

Incorporating the Continuity Equation into Manning's Equation yields Equation 6-3:

CHAPTER 6: HYDRAULICS OF SECONDARY DRAINAGE FACILITIES

$$V = \left(\frac{1.49}{n} \right) R^{2/3} S^{1/2} \quad \text{Equation 6-3}$$

The hydraulic radius can be expressed as a function of the diameter for circular pipes flowing full:

$$R = \frac{D}{4} \quad \text{Equation 6-4}$$

where: D = pipe diameter (feet).

Substituting Equation 6-4 into Equation 6-3 and rearranging to solve for slope of the pipe yields Equation 6-5:

$$S = \left[\frac{Vn}{1.49 \left(\frac{D}{4} \right)^{2/3}} \right]^2 \quad \text{Equation 6-5}$$

The n values used to obtain these slopes were obtained from Table 6-1. Equation 6-5 should be used to determine the range of acceptable slopes for other pipe materials, sizes, n values, and shapes.

TABLE 6-1: MINIMUM AND MAXIMUM ALLOWABLE SLOPES FOR STORM SEWERS						
Pipe Diameter (inches)	Pipe Slopes (%)					
	RCP (n = 0.013)		HDPE (n = 0.012)		CMP (n = 0.027)	
	Minimum	Maximum	Minimum	Maximum	Minimum	Maximum
18	0.11	1.802	0.096	1.535	0.486	7.771
21	0.092	1.467	0.078	1.250	0.395	6.327
24	0.077	1.228	0.065	1.046	0.331	5.296
27	0.066	1.049	0.056	0.894	---	---
30	0.057	0.912	0.049	0.777	0.246	3.933
36	0.045	0.715	0.038	0.609	0.193	3.084
42	0.036	0.582	0.031%	0.496	0.157	2.511
48	0.030	0.487	0.026	0.415	0.131	2.102
54	0.026	0.416	0.022	0.355	0.112	1.796
60	0.023	0.362	0.019	0.308	0.098	1.561
66	0.020	0.319	0.017	0.271	0.086	1.374

72	0.018	0.284	0.015	0.242	0.076	1.224
78	0.016	0.255	0.014%	0.217	0.069	1.100
84	0.014	0.231	0.012	0.197	0.062	0.997
90	0.013	0.211	0.011	0.180	0.057	0.909
96	0.012	0.193	0.010	0.165	0.052	0.834
102	0.011	0.178	0.009	0.152	0.048	0.769
108	0.010	0.165	0.009	0.141	0.045	0.713
120	0.009	0.144	0.008	0.122	---	---

6.2.4 Friction Losses

Friction losses in storm sewer systems may be computed using the following form of the Manning’s Equation:

$$H_F = \frac{(n^2 Q^2 L)}{(2.22 A^2 R^{4/3})} \quad \text{Equation 6-6}$$

where: H_F = friction loss (feet);

6.2.5 Minor Losses

Minor losses are those losses that result from changes in velocity or direction of flow. Although, minor losses in storm sewer systems are usually insignificant, they may exceed the H_F in relatively short storm sewer segments. In addition, the cumulative effect of minor losses may be significant in relatively flat areas like Jefferson County. Minor losses include those associated with: pipe entrances, pipe exits, pipe bends, pipe elbows, junctions, manholes, expansions, contractions, and appurtenances such as valves and meters. It is important to note that minor losses can be minimized by careful design. For example, severe pipe bends can be replaced by gradual curves if sufficient right-of-way is available and costs are manageable. Furthermore, well designed manholes and inlets without sharp or sudden transitions or flow impediments do not cause significant minor losses.

Minor losses are typically computed using a loss coefficient and flow velocities in upstream and downstream pipe segments. Although entrance losses, exit losses, and losses at inlets and manholes are discussed in detail in this section, it may be necessary to account for other minor losses depending on project specific considerations. For additional information on minor losses refer to TxDOT’s *Hydraulic Design Manual* or other hydraulic reference manuals. Equation 6-7 can be used to compute entrance losses:

$$H_E = K_e \frac{V^2}{2g} \quad \text{Equation 6-7}$$

CHAPTER 6: HYDRAULICS OF SECONDARY DRAINAGE FACILITIES

where: H_E = entrance loss (feet);
 K_e = the entrance loss coefficient, from Table 5-8, or 1.25 for inlets or manholes at the beginning of a storm sewer segment;
 V = velocity in the pipe (feet per second);
 g = the acceleration of gravity (32.2 feet per second²).

For this calculation, the velocity upstream of the pipe entrance is assumed to be zero. Table 5-8 provides a summary of entrance loss coefficients for a number of culvert entrance configurations. Equation 6-7 can also be used to compute exit losses and the exit loss coefficient may be assumed to be equal to 1.0 for most applications. Minor losses at inlets and manholes can be computed with Equation 6-8. Table 6-2 lists typical Minor loss coefficients for various inlet and manhole configurations.

$$H_{I/M} = \frac{(V_2^2 - KV_2^2)}{2g} \tag{Equation 6-8}$$

where: $H_{I/M}$ = loss at inlet or manhole (feet);
 K = the minor loss coefficient, from Table 6-2;
 V_1 = velocity in the upstream pipe (feet per second);
 V_2 = velocity in the downstream pipe (feet per second);
 g = the acceleration of gravity (32.2 feet per second²).

TABLE 6-2: MINOR LOSS COEFFICIENTS FOR INLETS AND MANHOLES	
Type of Structure	Coefficient (K)
Inlet on Main Line	0.50
Inlet on Main Line with Branch Lateral	0.25
Manhole on Main Line with 22.5-Degree Lateral	0.75
Manhole on Main Line with 45-Degree Lateral	0.50
Manhole on Main Line with 60-Degree Lateral	0.35
Manhole on Main Line with 90-Degree Lateral	0.25

6.2.6 Hydraulic Grade Line

As indicated previously, the HGL shall be maintained at an elevation below the gutter line at inlets and below the rim elevation at manholes during the design storm frequency determined from Section 6.1.1.

The tailwater elevation in the receiving channel or storm sewer system shall be determined using the Frequencies of Coincidental Occurrence methodology described in Section 5.2.5 and Table 5-3. This value will be the starting WSEL or HGL at the downstream end of the storm sewer system (outfall node). The HGL elevation at the upstream end (node) of each storm sewer segment can be estimated using Equation 6-9.

$$HGL_u = HGL_d + h_f + h_m \quad \text{Equation 6-9}$$

where: HGL_u = HGL at upstream end (node) of storm sewer segment (feet);
 HGL_d = HGL at downstream end (node) of storm sewer segment (feet);
 h_f = headloss due to friction (feet);
 h_m = sum of Minor losses (feet).

The HGL at the downstream end (node) of the next storm sewer segment upstream can be estimated as the upstream HGL calculated for the downstream segment of storm sewer from this node or the top of the upstream pipe, whichever is greater.

The HGL computations should proceed in an upstream direction into all branches of the storm sewer system. If the HGL elevation is above the gutter line at any inlets or the rim elevation at any manholes, the storm sewer system must be adjusted so that the HGL does not exceed these elevations. This can typically be accomplished by increasing the capacity of the storm sewer segments with the most significant losses. However, adjustments to storm sewer flowline elevations may also be required.

6.3 DESIGN OF ROADSIDE DITCHES

This section describes the general design requirements, design storm frequencies, and peak runoff rates for storm sewers.

6.3.1 Design Storm Frequencies

The following guidelines must be followed in the design of roadside ditches and associated culverts to be placed in roadside ditches.

- For drainage areas up to 50 acres, roadside ditches and culverts in those ditches should be designed to convey five-year peak runoff rates at maximum water levels not exceeding top of bank elevations. Peak 25-year runoff rates shall be accommodated with a maximum flow depth of six inches above the crown of the roadway.
- For drainage areas between 50 acres and 100 acres, roadside ditches and culverts in those ditches should be designed to convey ten-year peak runoff rates at maximum water levels not exceeding bank elevations. Peak 50-year runoff rates shall be accommodated with a maximum flow depth of six inches above the crown of the roadway.
- For drainage areas greater than 100 acres, roadside ditches will be considered as open channels. Refer to Chapter 5 for open channel design requirements.

6.3.2 General Design Requirements for Roadside Ditches

CHAPTER 6: HYDRAULICS OF SECONDARY DRAINAGE FACILITIES

The following general requirements shall be applied to the designs of all roadside ditches.

- Roadside ditches shall be designed with side slopes no steeper than 3 horizontal to 1 vertical (3:1).
- The minimum Manning's roughness coefficient for roadside ditch design shall be 0.04.
- The minimum grade for roadside ditches shall be 0.1-percent.
- Hydraulic computations which demonstrate that the ditch design is sufficient to carry design flow rates for the frequencies specified in Section 6.3.1 will be required.
- The ditch must be vegetated immediately after construction or repair to minimize erosion.
- Flow velocities are to be maintained at non-erosive levels. In areas where erosive velocities are anticipated, slope protection measures will be employed (see Chapter 8).
- The depth of roadside ditches shall be maintained between 1.5 feet and four feet. Roadside ditches greater than four feet in depth will be subject to the design requirements for open channels.
- The minimum culvert size for roadside ditches shall be 18 inches.
- The maximum head loss for a driveway culvert shall be limited to 0.1 feet.

6.3.3 Peak Runoff Rates

Design peak flow rates may be computed using the Rational Method.

6.4 DESIGN OF OTHER SECONDARY DRAINAGE FACILITIES

6.4.1 Types of Facilities

Other than storm sewers and roadside ditches, secondary drainage facilities may include sheet flow swales, small culverts, and other structures which are intended to handle relatively small volumes of storm runoff.

6.4.2 General Design Requirements

Secondary drainage facilities shall be designed to accommodate peak flow rates from a five-year design storm event without creating flooding problems or erosion hazards. Maximum five-year design water levels shall generally be kept below natural ground. Design methods for secondary drainage facilities must be based on sound engineering practice and widely-accepted methodologies. Examples include the Rational Method, Manning's Equation, standard orifice and weir flow equations, and Federal Highway Administration (FHWA) culvert design methods.

6.4.3 Peak Flow Rates

Peak design flow rates for secondary drainage facilities shall be computed using the Rational Method for drainage areas up to 200 acres. HEC-HMS shall be used to compute the peak flow

CHAPTER 6: HYDRAULICS OF SECONDARY DRAINAGE FACILITIES

rates for drainage areas greater than 200 acres. Complete peak flow calculations must be submitted in support of all proposed structure designs.

6.5 LOT GRADING AND DRAINAGE

Individual lots should be graded in accordance with the following guidelines:

- Lots should be graded to drain to a street, swale, road or outfall ditch at a minimum slope of one-percent.
- Wherever possible, sheet flow from individual lots should not cross adjacent lots before entering a street, swale, ditch, or other drainage facility.
- All finished floor elevations should be at least 12 inches above the highest finished ground elevation immediately adjacent to the slab.
- For lots draining to a street, the finished floor elevation should be at least 12 inches above the highest point along the top of the curb immediately adjacent to the building.
- All finished floor elevations should be at least two feet above the design water surface elevation or computed base flood elevation in any adjacent drainage facility.

Exhibits 6-6 and 6-7 show the lot grading requirements described above.

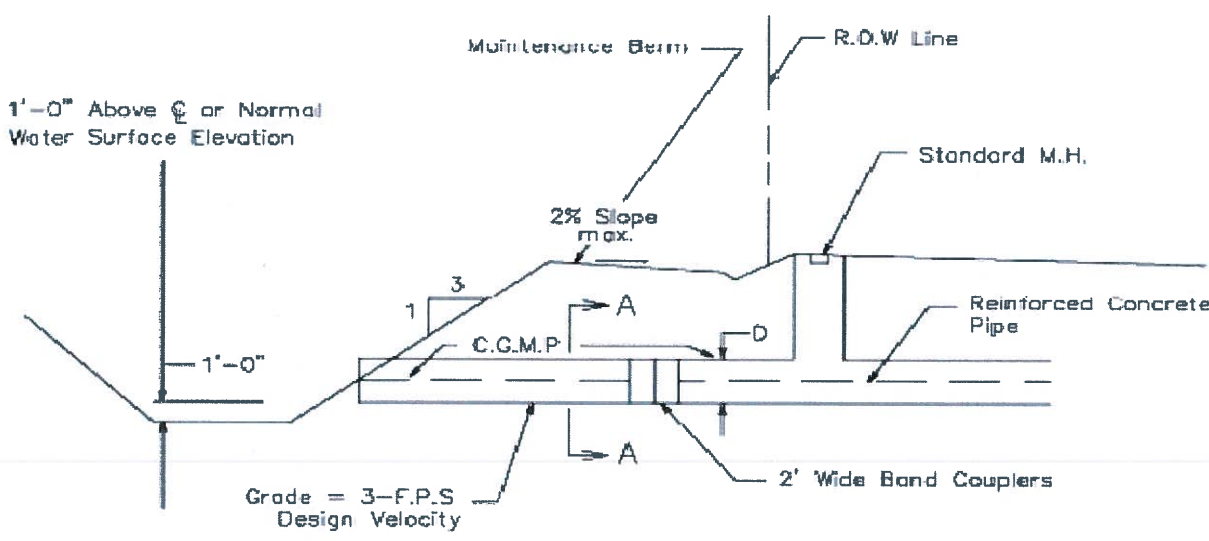

ELEVATION

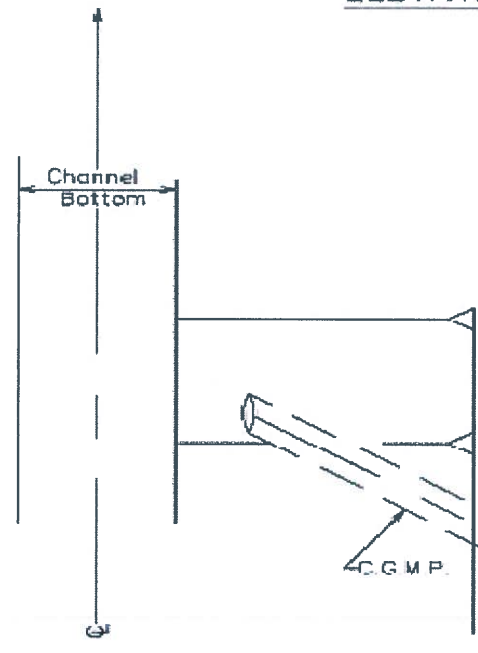

PLAN

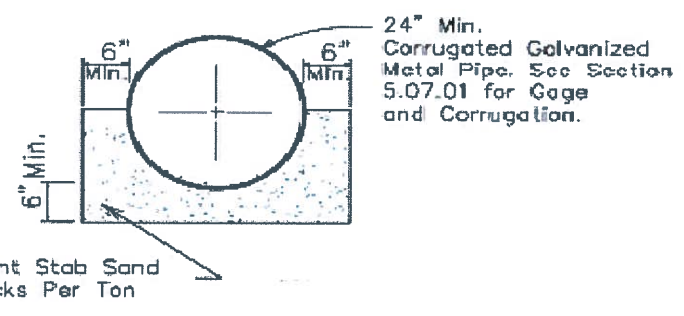

SECTION A-A

TYPICAL STORM SEWER OUTFALL STRUCTURE
(24-INCH TO 42-INCH)



DRAINAGE
CRITERIA
MANUAL

EXHIBIT #: 6-1
DATE: SEPTEMBER 2018

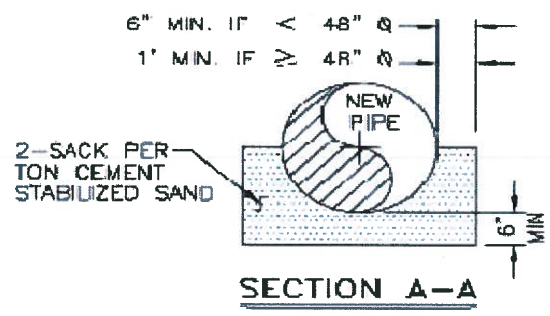
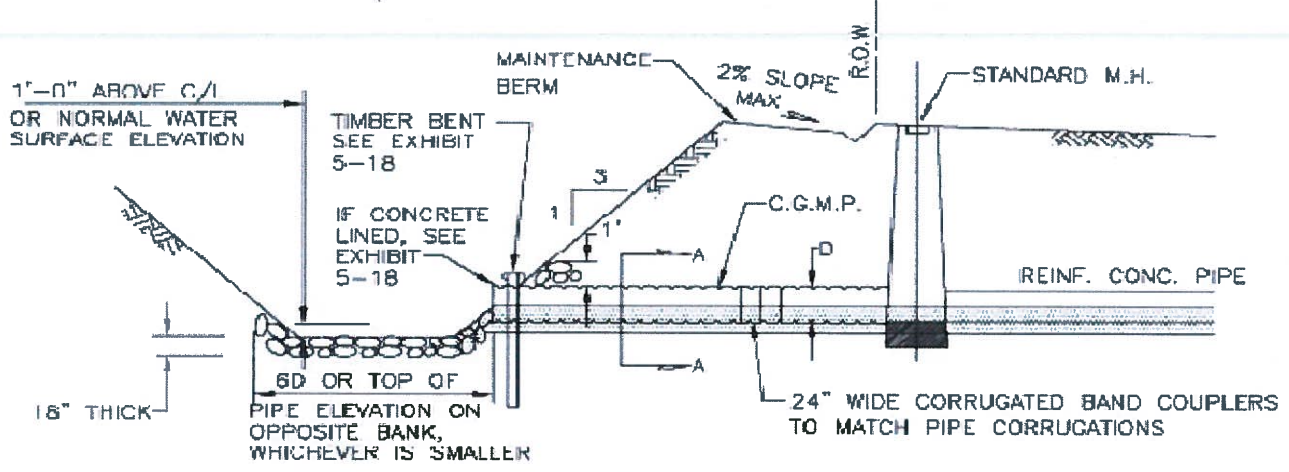
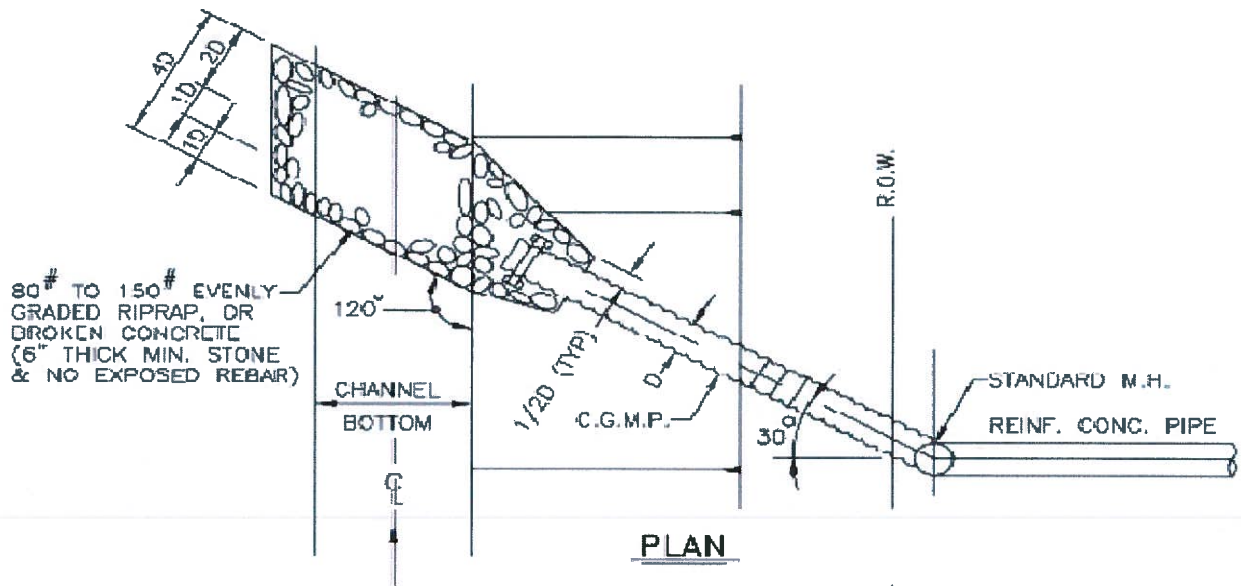

TYPICAL STORM SEWER OUTFALL STRUCTURE (48-INCH AND LARGER)



DRAINAGE CRITERIA MANUAL

EXHIBIT #: 6-2
DATE: SEPTEMBER 2018

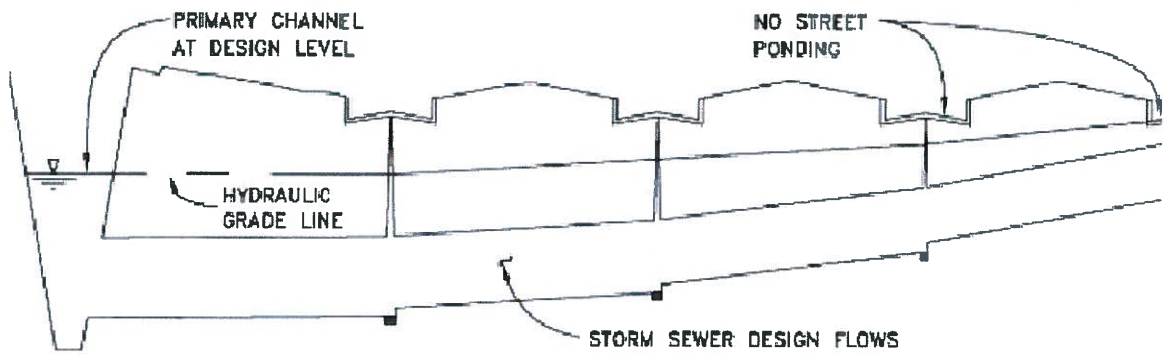

A) STANDARD STORM SEWER DESIGN CONDITION.

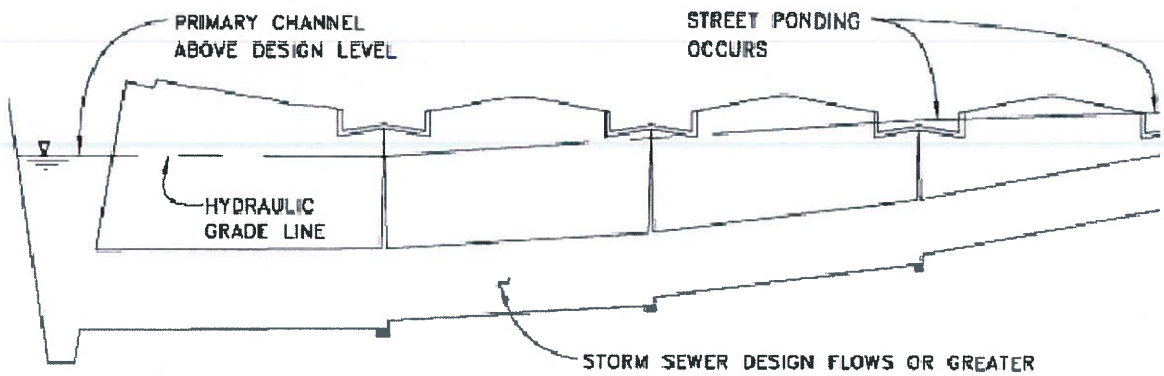

STREET PONDING DUE TO TAILWATER HIGHER THAN DESIGN LEVEL OR RAINFALL IN EXCESS OF DESIGN EVENT IN STORM SEWER.

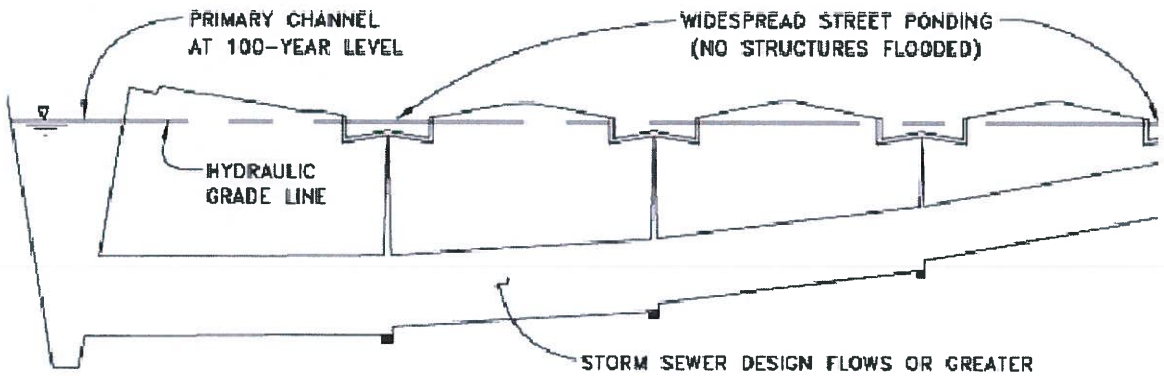

C) DRAINAGE SYSTEM OPERATING AT MAXIMUM CAPACITY.

TYPICAL STORM SEWER AND CHANNEL INTERACTION



DRAINAGE CRITERIA MANUAL

EXHIBIT #: 6-3

DATE: SEPTEMBER 2018

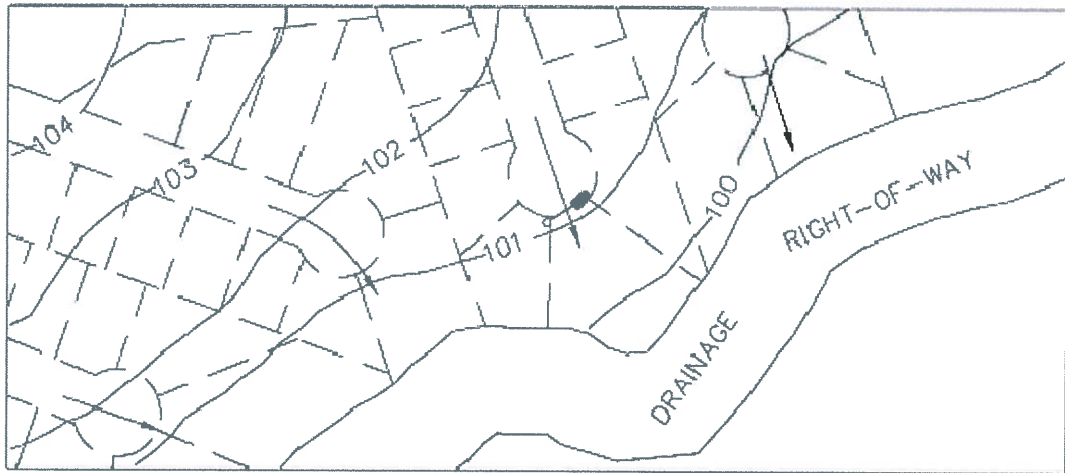

A

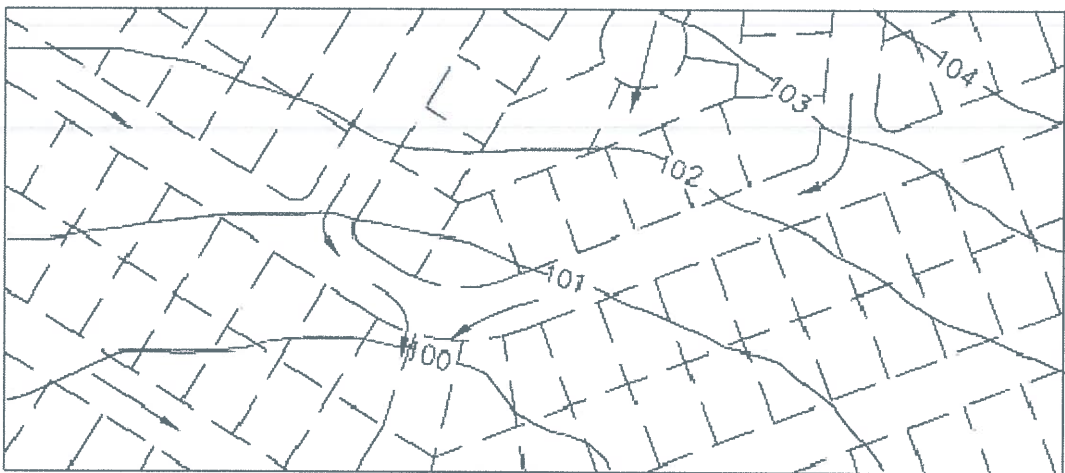

B

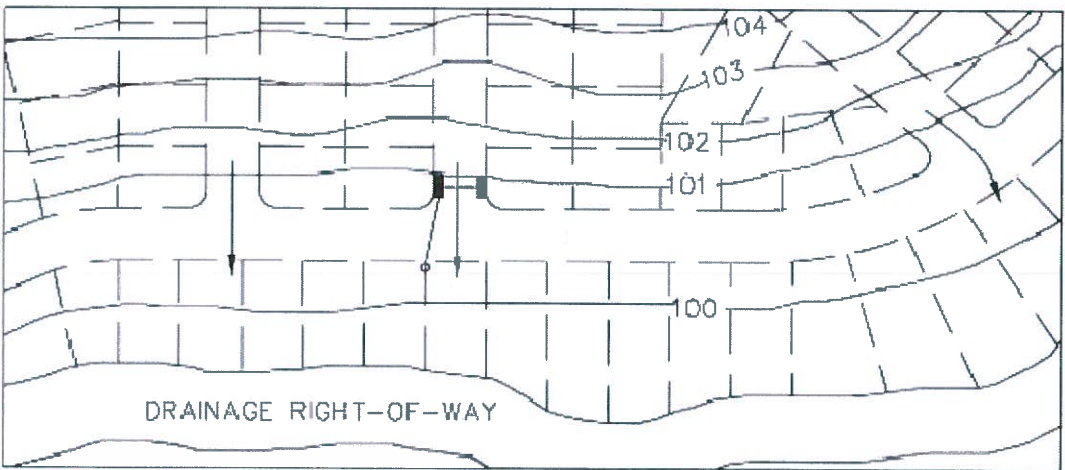

C

UNDESIRABLE SHEET FLOW PATTERNS



DRAINAGE
CRITERIA
MANUAL

EXHIBIT #: 6-4

DATE: SEPTEMBER 2018

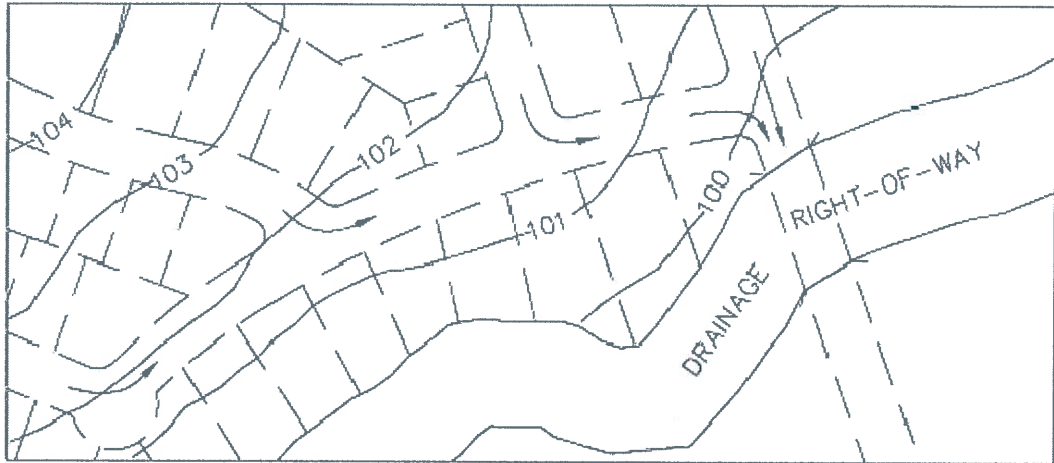

A

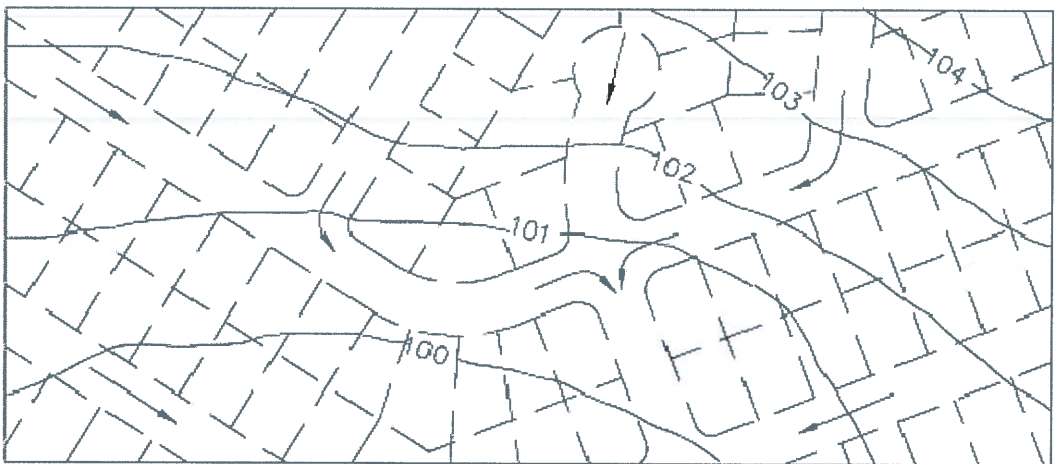

B

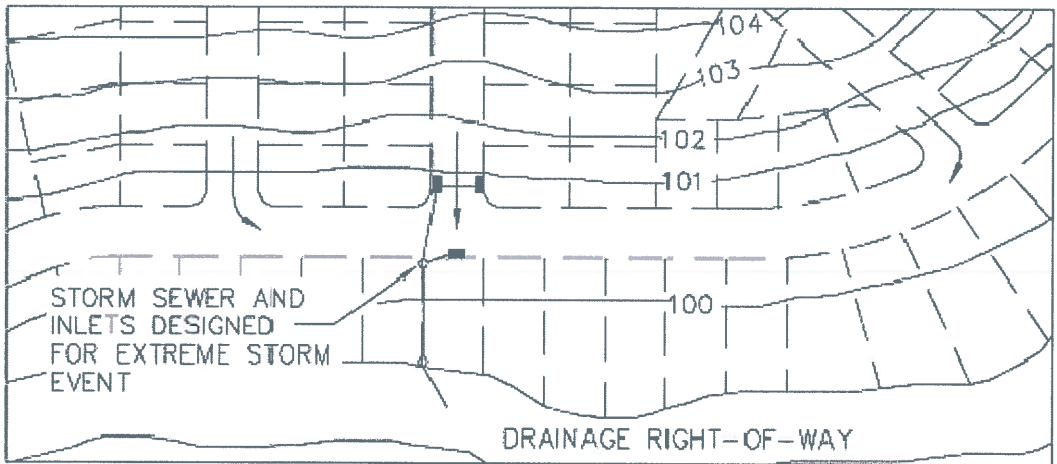

C

ACCEPTABLE SHEET FLOW PATTERNS



DRAINAGE
CRITERIA
MANUAL

EXHIBIT #: 6-5

DATE: SEPTEMBER 2018



REQUIREMENTS FOR LOT DRAINAGE DESIGN
 (CROSS-SECTION VIEW)

DRAINAGE
 CRITERIA
 MANUAL



EXHIBIT # _____ 6-6
 DATE: _____ SEPTEMBER 2018

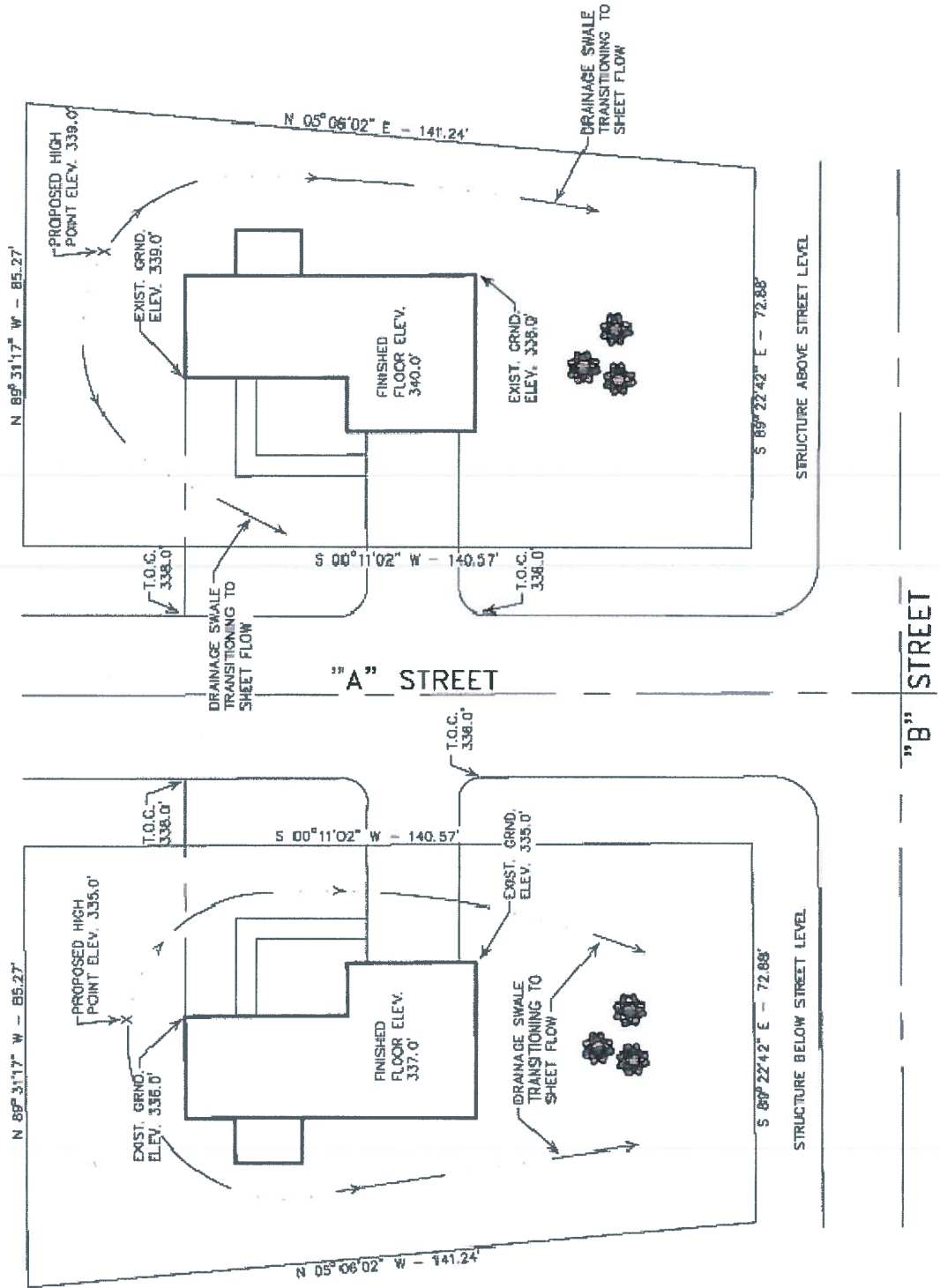

REQUIREMENTS FOR LOT DRAINAGE DESIGN
(PLAN VIEW)



DRAINAGE
CRITERIA
MANUAL

EXHIBIT #: 6-7

DATE: SEPTEMBER 2018

7. DETENTION ANALYSIS

The purpose of this chapter is to provide criteria and guidelines to be used in the analysis of detention facilities. Detention facilities are intended to mitigate increases in peak flows and changes in the timing of runoff associated with urbanization so that surrounding properties and the receiving body of water are not adversely impacted by increases in peak flows or water surface elevations (WSELs). Refer to Chapter 3 for additional information on the effects of urbanization.

It is important to note that detention will be required for the following types of improvements: new development; redevelopment; roadway expansion; drainage system improvements; and any other improvements that increase the impervious cover, decrease the time of concentration (T_c), or increase the peak flows from a drainage area. Additional information on impervious cover, T_c values, and peak flows is provided in Chapter 4.

The civil engineering industry's standard of care for detention analysis is the 100-year event, which is typically used by public entities requiring detention. In addition, the 100-year rainfall event is used by the Federal Emergency Management Agency (FEMA) to define the level of flooding risk within communities that participate in the National Flood Insurance Program (NFIP). Therefore, the 100-year design storm event will be used as the basis for detention analysis within DD7's boundaries and jurisdiction. In some instances, five-year and 25-year design storm events will also need to be analyzed to ensure that the proposed detention facility does not cause adverse impacts during more frequent rainfall events.

7.1 GENERAL DESIGN REQUIREMENTS

The following design requirements are discussed in this section: design storm frequencies, detention basin location and geometry, maintenance berms, maintenance, pumped detention facilities, multi-purpose design, and extreme event overflow structures.

7.1.1 Design Storm Frequencies

The following design storm frequencies should be used for detention analysis and design.

- The required storage volume for detention basins serving up to 200 acres (that are analyzed using the simplified methodology described in Section 7.3) shall be designed for a 100-year design storm event.
- Detention basins serving drainage areas greater than 200 acres and areas up to 200 acres that are analyzed using the methodology described in Section 7.4 shall be analyzed for the 10- and 100-year design storm events.

7.1.2 Detention Basin Location and Geometry

In order to facilitate pavement and storm sewer drainage, detention basins should typically be located in the lowest portion of the drainage area contributing to the basin. In addition, detention basins should be located immediately adjacent to the receiving drainage system where feasible. This will minimize the required length of outfall pipe and decrease maintenance strip requirements (see Section 7.1.3), which may decrease overall drainage system costs. The basic geometry of a typical detention basin is illustrated on Exhibits 7-1 and 7-2. The following criteria shall be used in detention basin design:

- Side slopes of detention basins shall be no steeper than three horizontal to one vertical (3:1). However, the use of these side slopes should be verified by a geotechnical report. If soil conditions are conducive to slope instability, flatter side slopes may be required.
- A minimum transverse slope of 0.50-percent shall be used on the bottom of the detention basin.
- A minimum of one-foot of freeboard shall be provided in the detention basin.
- A six-foot wide concrete pilot channel with a depth of four inches shall be provided in the bottom of the basin to facilitate drainage and avoid erosion problems. A minimum slope of 0.10-percent shall be used for concrete pilot channels.
- Earthen pilot channels with a minimum depth of two feet may be substituted for concrete pilot channels for aesthetic reasons or to facilitate multi-purpose use of a detention facility. The minimum slope for earthen pilot channels is 0.20-percent and the side slopes of earthen pilot channels shall be no steeper than three horizontal to one vertical (3:1).
- The minimum allowable outfall pipe size is 18 inches. If the detention analysis shows that a smaller pipe is required to restrict discharges, then a restrictor shall be placed inside an 18-inch diameter pipe.
- The use of parking lot detention storage is acceptable provided that the maximum ponding depth does not exceed six inches. However, it is recommended that preliminary approval be obtained from DD7's Staff prior to beginning a detailed design of any parking lot detention facility.

7.1.3 Maintenance Berms

For detention basins proposed to be maintained by DD7, a minimum 30-foot maintenance strip shall be provided around the entire detention basin. Detention basins located immediately adjacent to a drainage channel with a dedicated right-of-way (ROW) and a maintenance strip wide enough to satisfy channel design criteria may share the adjacent channel maintenance strip. However, the combined total width of the channel and detention basin maintenance strips shall not be less than 30 feet under any circumstances.

For detention basins proposed to be maintained privately, a minimum 20-foot maintenance strip shall be provided around the entire detention basin. Detention basins located adjacent to parking lots may satisfy ten feet of the maintenance strip requirement with the paved parking area. However, adequate access for maintenance equipment must be provided.

7.1.4 Maintenance

All detention facilities shall be located in readily accessible areas and two access routes should be provided where possible. The following maintenance activities should be performed on a regular basis: mowing, slope repairs, removal of accumulated sediments, and repairs to discharge structures. In addition, a maintenance schedule should be prepared in conjunction with the detention design and periodically updated by the agency or entity responsible for maintenance of the detention facility. **DD7 will not be responsible for the maintenance of detention facilities designed to mitigate the development of individual private projects or the construction of infrastructure improvements projects intended to serve private developments.**

7.1.5 Pumped Detention Facilities

Detention facilities which rely on pumps to discharge all or part of the storm water which flows into them are generally not recommended. For facilities where pumps are required, the pump facilities should possess sufficient discharge capacity to accommodate the design 100-year peak discharge rate with the largest pump out of service. However, these facilities will require approval by the DD7.

7.1.6 Multi-Purpose Design

DD7 encourages multi-purpose features in detention facilities provided that the storm water management function of the facility is not compromised. In addition, the multi-purpose detention facilities must be designed to accommodate the maintenance activities discussed in Section 7.1.4 and to provide safety features. Recommended multi-purpose features include permanent ponds, wetlands, playgrounds, soccer fields, and hiking or biking trails.

7.1.7 Extreme Event Overflow Structures

All detention basins shall be designed so that storm water runoff in excess of the 100-year rainfall event is conveyed to the nearest drainage channel without flooding structures. Overflow depths up to one-foot above basin top of bank elevations should be considered. Grass-lined earthen swales, weirs, concrete-lined overflow sections, and other structures may be utilized to convey these overflows.

7.2 PEAK DISCHARGE RATES

The following items related to peak discharge rates are discussed in this section: methodology, allowable peak discharge rates, and off-site flows.

7.2.1 Methodology

As described in Chapter 4, the Rational Method may be used for drainage areas up to 200 acres, and HEC-HMS shall be used for drainage areas greater than 200 acres to determine peak discharge rates consistent with the aforementioned criteria. For drainage areas greater than 200 acres or for smaller drainage areas being analyzed with the detention routing methodology described in Section 7.4, inflow hydrographs shall be computed by HEC-HMS.

7.2.2 Allowable Peak Discharge Rates

- For detention facilities serving drainage areas up to 200 acres, the maximum allowable peak discharge rate shall be limited to the existing conditions 10- and 100-year peak discharge rates for the 10- and 100-year design storm events, respectively.
- For detention basins with drainage areas greater than 200 acres, the peak discharge shall also be restricted to the existing conditions 10- and 100-year peak discharge rates for the 10- and 100-year design storm events, respectively.

It is important to note that limiting discharges during the two rainfall events may require multiple outfall structures (i.e., a low-flow pipe with a larger diameter pipe or weir stacked above).

7.2.3 Off-Site Flows

An investigation of off-site flows shall be completed as part of every drainage study or detention analysis. Off-site flows that drain through a project must be accommodated by the proposed drainage plan. When off-site (run-on) flows are routed through a detention basin, the allowable peak discharge rates shall be based on the entire contributing (project and off-site) drainage area. For this case, regardless of acreage, the detailed detention analysis methodology described in Section 7.4 must be used.

A downstream off-site drainage facility may be required to convey the storm water from the project site to the receiving system, with sufficient 100-year capacity based upon contributing upstream acreage under existing conditions. This offsite drainage facility shall have sufficient drainage easement for conveyance and maintenance purposes. For the width of the ROW required for channels, see Section 5.1.2 for earthen channels and Section 5.1.3 for concrete-lined channels. For enclosed systems, the minimum ROW width is equal to the widest dimension of the underground conduit plus two times the maximum depth from finished ground to the invert of the conduit, or 30 feet, whichever is greatest.

7.3 DETENTION ANALYSIS FOR DRAINAGE AREAS UP TO 200 ACRES

This section describes the methodology to be used in determining the required detention storage volume and outfall structure size for drainage areas up to 200 acres.

2.6.2 Detention Analysis for Drainage Areas Up to 200 Acres

The simplified detention analysis methodology developed for drainage areas up to 200 acres is based on the triangular hydrograph method. Equations 7-1 through 7-3 can be used to compute the required detention storage volume as the area between triangular inflow and outflow hydrographs for the basin (Exhibit 7-3). In this method, the outflow hydrograph is assumed to intersect the receding limb of the inflow hydrograph at a flow rate equal to the maximum allowable peak discharge rate from the detention facility. Equation 7-1 can be used to calculate the time base of the triangular inflow hydrograph (B):

$$B = \frac{43,560V_R}{0.5Q_I} \quad \text{Equation 7- 1}$$

where: B = time base of the triangular inflow hydrograph (seconds);
 V_R = the detention inflow volume in (acre-feet);
 Q_I = the proposed 100-year peak inflow rate (cubic feet per second).

The detention inflow volume (V_R) can be computed using Equation 7-2:

$$V_R = A(XS) \quad \text{Equation 7- 2}$$

where: A = drainage area served by detention basin (acres);
 XS = rainfall excess, from Table 7-1 (feet).

The rainfall excess shall be determined from Table 7-1 based on the soil type and proposed impervious cover of the drainage area. If the proposed impervious cover falls between the values listed in this table, then the rainfall excess should be estimated by interpolation.

TABLE 7-1: 100-YEAR RAINFALL EXCESS VALUES FOR JEFFERSON COUNTY, TEXAS				
% Impervious Cover	Rainfall Excess by Soil Groups (feet)			
	A	B	C	D
0	0.03	0.43	0.81	0.95
10	0.14	0.51	0.85	0.98
20	0.26	0.58	0.89	1.00
30	0.37	0.66	0.92	1.02
40	0.49	0.73	0.96	1.04
50	0.61	0.81	1.00	1.07
60	0.72	0.88	1.04	1.09
70	0.84	0.96	1.07	1.11
80	0.95	1.03	1.11	1.14
90	1.07	1.11	1.15	1.16
100	1.18	1.18	1.18	1.18

Equation 7-3 can be used to estimate the detention storage requirement (V_s) for drainage areas up to 200 acres.

$$V_s = \frac{0.5B(Q_i - Q_o)}{43,560} \qquad \text{Equation 7- 3}$$

where: V_s = detention storage requirement (acre-feet);
 Q_o = maximum allowable peak discharge rate (cubic feet per second).

7.3.1 Design of Outfall Structures for Drainage Areas up to 200 Acres

Detention outfall structures shall be designed to limit discharges to the allowable peak discharge rates described in Section 7.2.2. If requested by DD7 or if tailwater conditions in the receiving system warrant, the detention routing analysis and outfall structure sizing described in Section 7.4 shall be used. Otherwise, the required outfall pipe diameter for drainage areas up to 200 acres can be estimated by trial and error calculations using the procedure described in this section. Equation 7-4 is an acceptable head loss equation for pipe culverts flowing full that can be used to solve for pipe diameter:

CHAPTER 7: DETENTION ANALYSIS

$$H_T = \left[\frac{2.52(1 + K_e)}{D^4} + \frac{466n^2L}{D^{16/3}} \right] \frac{Q^2}{100} \quad \text{Equation 7-4}$$

where: H_T = available head (feet);
 K_e = entrance loss coefficient, typically 0.5;
 D = diameter of pipe (feet);
 n = Manning's roughness coefficient, from Table 7-4;
 L = length of culvert (feet);
 Q = design discharge rate (cubic feet per second).

If a HEC-RAS model of the receiving channel exists, then the Frequencies of Coincidental Occurrence methodology described in Chapter 7 shall be used to determine the constant tailwater in the receiving channel and to calculate the available head (H_T) for the 100-year analysis using Equation 7-5. Otherwise, an H_T of two feet can be assumed for the 100-year design storm event. In addition, an H_T of two feet should be used for the 10-year design storm event.

$$H_T = h_{basin} - h_{channel} \quad \text{Equation 7-5}$$

where: H_T = available head (feet);
 h_{basin} = 100-year design WSEL in detention basin (feet);
 $h_{channel}$ = tailwater elevation in channel from Frequencies of Coincidental Occurrence (feet).

Once a pipe diameter is selected, Equation 7-6 shall be used to calculate the design peak discharge rate for the design storm event specified in Section 7.2.1 to ensure that the maximum allowable discharge rate is not exceeded.

$$Q = \sqrt{\frac{100H_T}{\frac{2.52(1 + K_e)}{D^4} + \frac{466n^2L}{D^{16/3}}}} \quad \text{Equation 7-6}$$

If the HEC-HMS detention routing methodology described in Section 7.4 is used to analyze a detention basin with a drainage area less than or equal to 200 acres, then the outfall structure shall also be sized using the methodology for drainage areas greater than 200 acres.

7.4 DETENTION ANALYSIS FOR DRAINAGE AREAS GREATER THAN 200 ACRES

A detailed detention routing analysis is required for detention basins serving drainage areas greater than 200 acres. As indicated previously, this method may also be used for drainage areas less than 200 acres. Detention routing shall be performed for the 10- and 100-year rainfall events and the allowable peak discharge rates shall be determined from Section 7.2.2. Sections 7.4.1 through 7.4.4 discuss the hydrologic and hydraulic data required to develop detention routing models.

7.4.1 Acceptable Detention Routing Software Programs

The detention routing may be performed in HEC-HMS, HEC-RAS unsteady flow, Storm Water Management Model (SWMM), a detention routing spreadsheet, or other generally accepted detention basin routing programs approved by the DD7. The HEC-HMS and HEC-RAS manuals referenced in Chapters 4 and 5 should be consulted for additional information regarding the detention routing capabilities of these programs.

7.4.2 Inflow Hydrographs

Proposed conditions inflow hydrographs for the various design storm events should be developed in HEC-HMS using the hydrologic criteria presented in Chapter 4.

7.4.3 Stage-Storage Relationship

A stage-storage or stage-area relationship should be developed from the detention basin grading plan and entered into the detention routing model.

7.4.4 Outfall Structure

Detention outfall structures shall be designed to limit discharges to the allowable peak discharge rates described in Section 7.2. Depending on the detention routing software program, the outfall structure will either be input directly into the model or simulated with a stage-discharge relationship calculated independently and entered into the model. For HEC-HMS, the outfall structure is described using a stage-discharge relationship. For HEC-RAS unsteady flow or other unsteady flow models, the size and material of the outfall structure along with tailwater conditions within the receiving channel are entered into the model and a stage-discharge relationship is computed automatically. In either case, the required size of the outfall structure is dependent on tailwater conditions within the receiving channel.

A constant tailwater elevation in the receiving channel shall be estimated using the Frequencies of Coincidental Occurrence methodology described in Chapter 5. This constant tailwater elevation can be used to develop a stage-discharge relationship for an outfall structure of a specific diameter using Equation 7-6 or other hydraulic modeling program. The calculated stage-discharge relationship can then be incorporated into HEC-HMS or another acceptable model. In areas where tailwater conditions are a concern (i.e., detention basins located in 100-year flood plains, channels where WSELs remain high for long periods, channels with steeply rising WSELs, and areas with existing flooding problems), a stage hydrograph (elevation versus time) shall be developed for the

CHAPTER 7: DETENTION ANALYSIS

receiving channel and used in a HEC-RAS unsteady flow model or other acceptable software that allows stage hydrographs as a downstream boundary condition.

As indicated in Section 7.2.7, an extreme event overflow structure must be provided in all detention basins to accommodate storm water runoff in excess of the 100-year event without flooding structures. Standard hydraulic methods shall be used to determine the required dimensions of the overflow structure.

7.4.5 Acceptable Results

Once preliminary detention routing results are obtained, the peak discharge rate from the proposed detention basin shall be compared to the allowable peak discharge rate for each design storm event being analyzed (see Section 7.2.2). If the peak discharge rate for any of the design storm events exceeds the allowable peak discharge rate for that event, the size and/or configuration of the outfall structure shall be adjusted until acceptable results are obtained. In addition, the detention basin grading plan may also need to be revised to ensure that adequate volume is provided to maintain one-foot of freeboard in the basin. If the grading plan is revised, an updated stage-storage relationship will need to be developed and incorporated in the detention routing model.

7.5 DOWNSTREAM IMPACTS

For drainage areas greater than 640 acres or if requested by DD7 for smaller drainage areas, a HEC-HMS downstream impacts analysis shall be performed to demonstrate that the proposed detention facility does not cause any impacts (increases in peak flows) downstream of the detention facility. If prior approval is obtained from DD7, other standard software may be used for the downstream impacts analysis. DD7 has the option to request a downstream impacts analysis for drainage areas located in the lower half of their respective watershed. If a downstream impacts analysis is requested for drainage areas up to 200 acres, then the hydrologic methodology for drainage areas over 200 acres (see Chapter 4) and the detention routing method for drainage areas over 200 acres (Section 7.4) shall be used. The downstream impacts analysis shall be performed for the 10- and 100-year rainfall events. At a minimum, the downstream impacts analysis shall compare peak discharges downstream of the site to the mouth of the receiving channel. However, DD7's staff has the option to request that the downstream impacts analysis be continued further downstream.

CHAPTER 7: DETENTION ANALYSIS

The routed outflow hydrograph from the detention basin should be incorporated into a detention conditions HEC-HMS model of the receiving channel. The resulting peak discharge rates downstream of the proposed detention shall be compared to the existing conditions peak discharges rates prior to development of the project site. If the drainage area served by the proposed detention basin is part of a larger drainage area, then the larger area should be subdivided to create revised existing and detention conditions models where the area served by the detention basin is represented by a stand-alone sub-basin. If the analysis indicates that there are increases in peak flows downstream of the proposed detention facility, then the discharge structure and/or detention basin shall be modified to eliminate these increases. This process is illustrated in Figure 7-1.

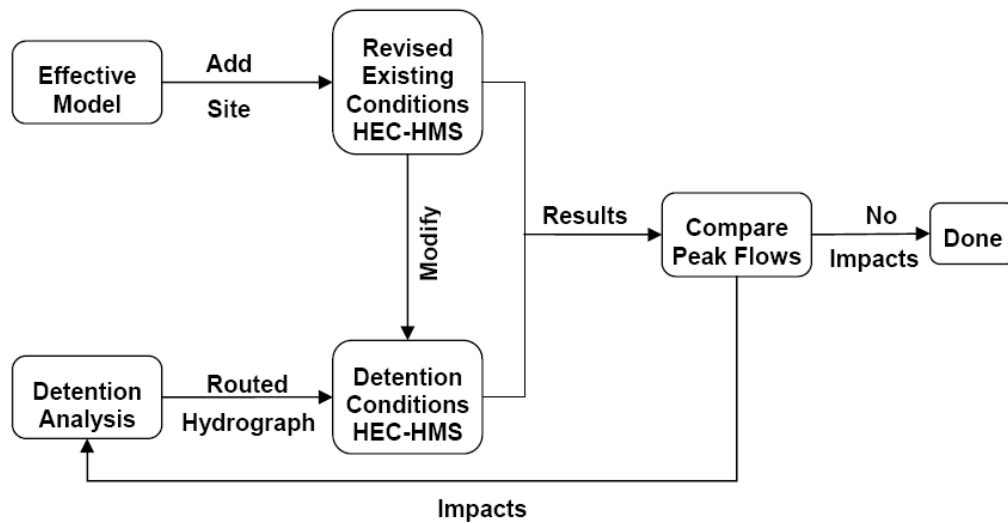
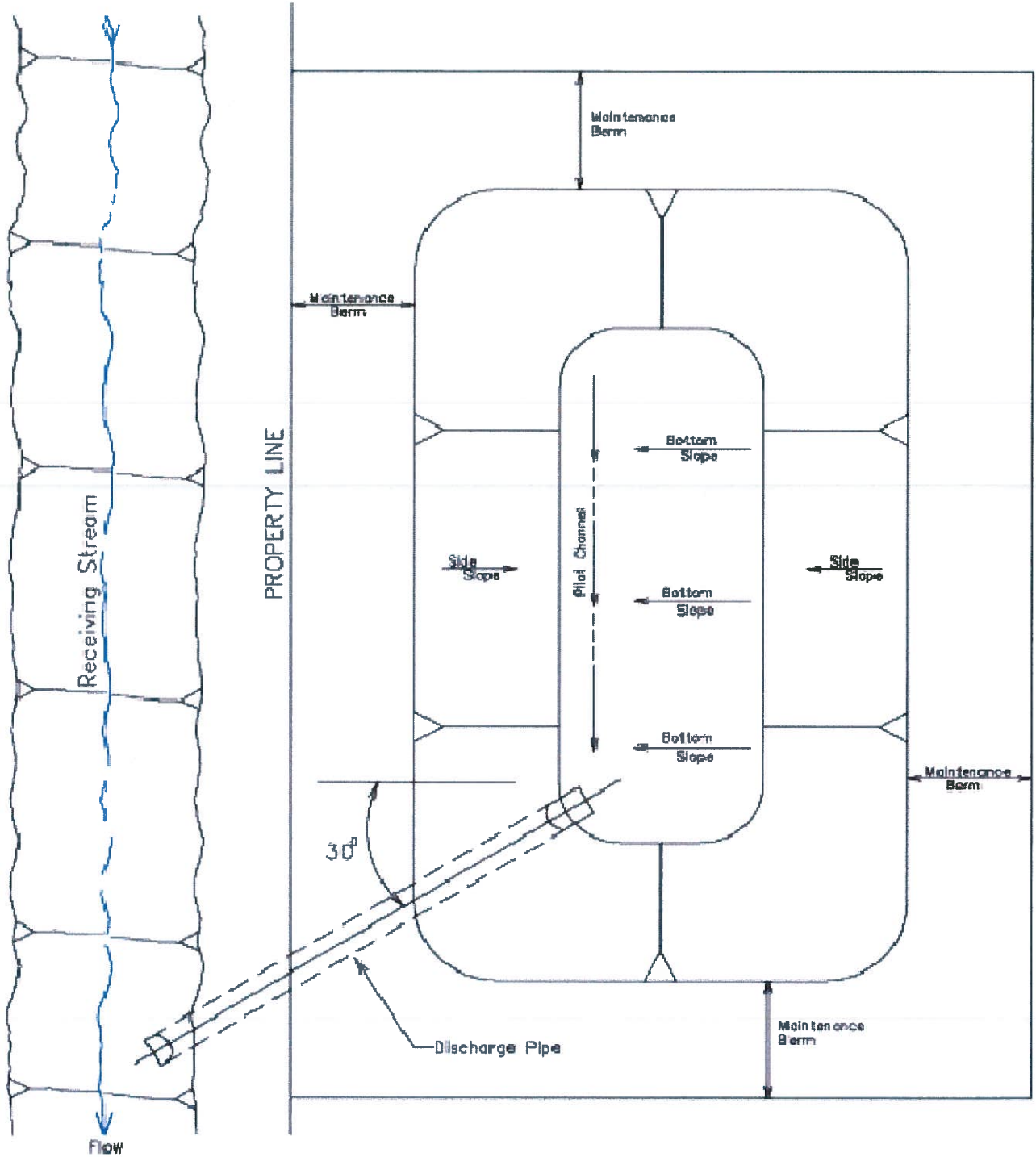

Figure 7-1: Downstream Impacts Analysis Process



TYPICAL DETENTION BASIN LAYOUT



DRAINAGE
CRITERIA
MANUAL

EXHIBIT #: 7-1

DATE: SEPTEMBER 2018

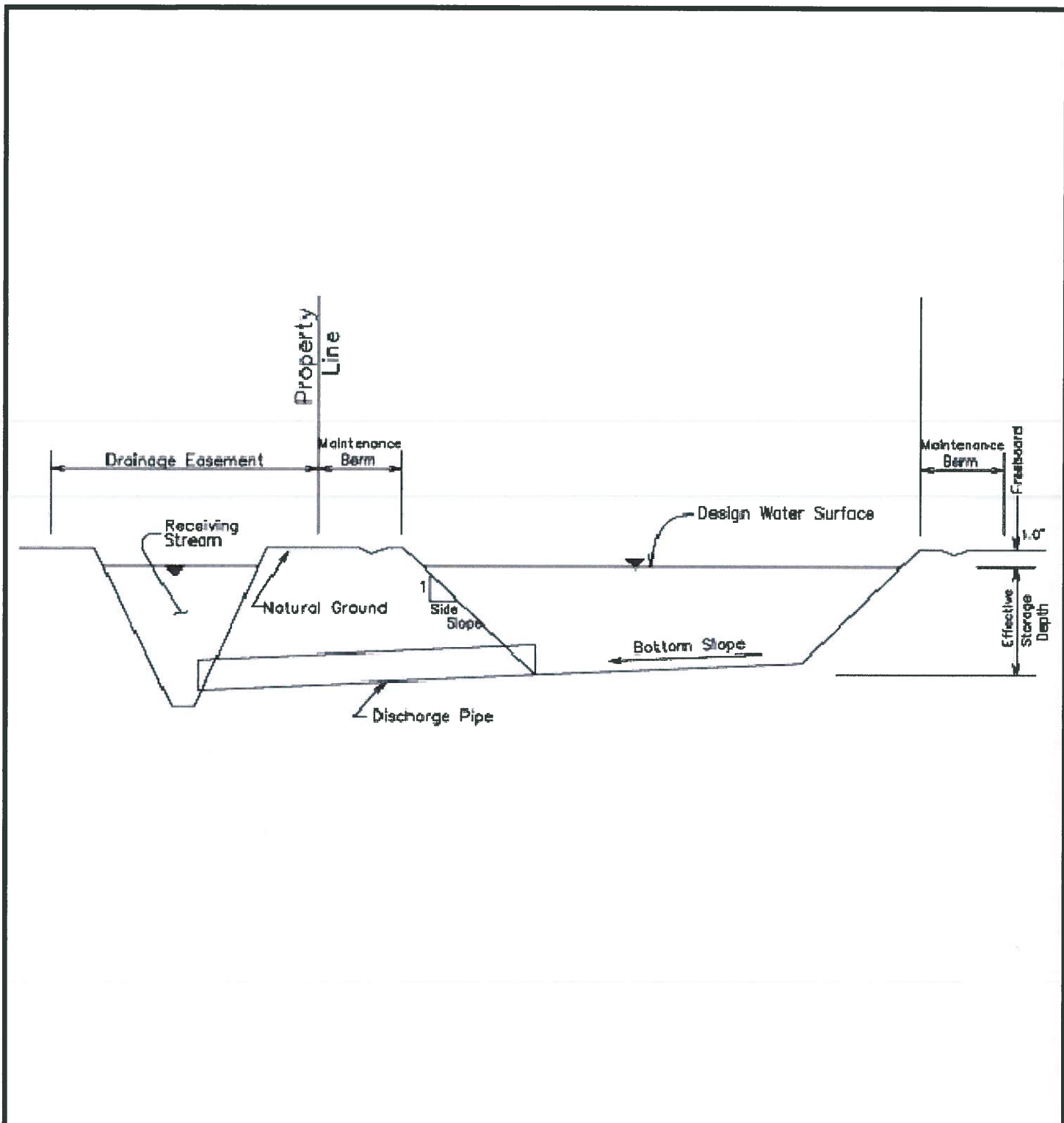

TYPICAL DETENTION BASIN
CROSS-SECTION



DRAINAGE
CRITERIA
MANUAL

EXHIBIT #: 7-2

DATE: SEPTEMBER 2018

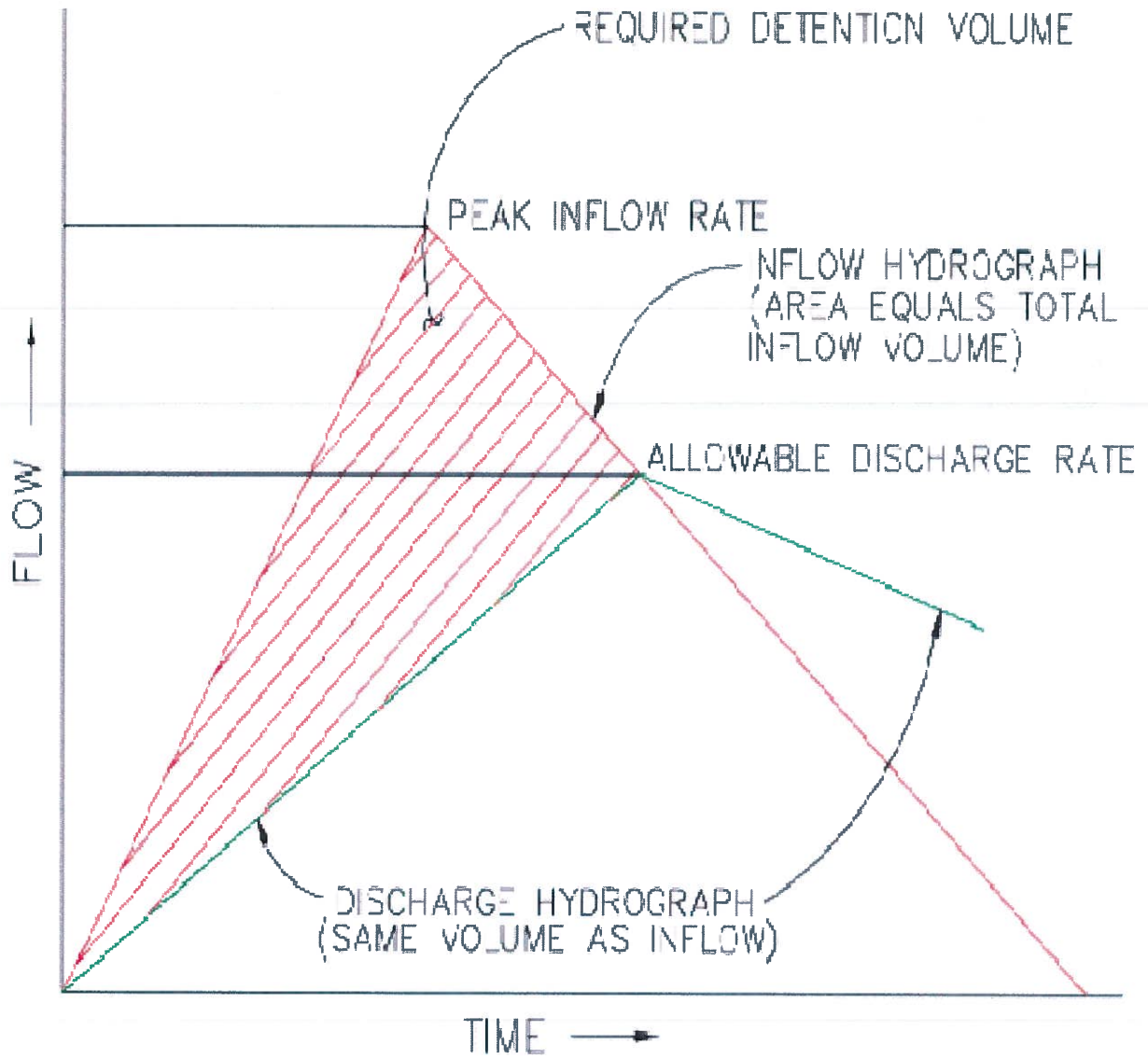

DETENTION STORAGE
VOLUME FOR DRAINAGE AREAS
UP TO 200 ACRES



DRAINAGE
CRITERIA
MANUAL

EXHIBIT #: 7-3

DATE: SEPTEMBER 2018

8. EROSION AND SEDIMENT CONTROL

This section of the manual describes methods for controlling erosion and sediment deposition in drainage facilities within Drainage District No. 7's boundaries.

8.1 EFFECTS OF EROSION AND SEDIMENTATION

Erosion and sedimentation can have very serious effects on storm water drainage. Some of these effects are summarized below:

- **Integrity of Drainage Facilities:** Erosion can cause slope failures, increase roughness coefficients, and generally reduce the efficiency of drainage channels. However, sediment deposition can clog drainage culverts and reduce the available conveyance in open channels.
- **Maintenance:** Erosion can significantly reduce the maintainability of drainage facilities and increase the cost of maintenance by increasing the frequency with which repairs are required.
- **Water Quality:** Erosion and sedimentation can increase the turbidity of water and may cause other water quality problems associated with pollutants attached to soil particles.

8.2 AREAS WITH HIGH EROSION POTENTIAL

Areas with relatively high erosion potential include the following:

- In channel bends, especially where the radius of curvature is less than three times the top width of flow in the channel.
- Around bridges and culverts where channel transitions and reduced flow areas create increased flow velocities.
- In steep sections of channels and ditches and on steep, unprotected slopes where flow velocities may reach erosive levels.
- Along grass-lined channel side slopes where significant amount of storm water runoff flows over the channel bank and down the sides of the channel.
- At confluences where flows in tributary channels, storm sewers, or roadside ditches enter a receiving channel.
- In areas where non-cohesive soils are particularly prone to erosion.

8.3 SLOPE PROTECTION METHODS

The following sections describe some of the most common slope protection methods.

8.3.1 Turf Establishment

The establishment of grass on exposed earthen side slopes is the most common method for protecting the slopes from erosion. Grass establishment should be initiated as quickly as possible after channel construction or repair work is completed. The grasses used for this purpose should be of hardy varieties which do not require repeated watering and excessive amounts of care once they are established. Grasses with deep root systems are preferable to those with shallower root systems because they are more resistant to drought.

8.3.2 Slope Paving

Concrete slope paving is an effective slope protection method, but is too expensive to apply over large areas. Therefore, slope paving is most commonly used in limited areas where the potential for erosion is very high. Table 8-1 provides a summary of slope paving requirements for varying channel side slopes.

TABLE 8-1: MINIMUM THICKNESS AND REINFORCEMENT FOR CONCRETE SLOPE PAVING			
Channel Side Slope (H:V)	Minimum Thickness (inches)	Minimum Reinforcement	
		Material	Dimensions
3:1	4 inches	welded wire fabric	6 x 6 x W2.9 x W2.9
2:1	5 inches	welded wire fabric	6 x 6 x W4.0 x W4.0
1.5:1	6 inches	reinforcement	4 x 4 x W4.0 x W4.0

Minimum requirements for concrete slope paving are as follows.

- All concrete slope paving shall consist of Class A concrete.
- The side slopes of the channel shall be no steeper than 1.5 horizontal to 1 vertical (1.5:1).
- All slope paving shall include a toe wall at the top and sides with a minimum depth of 18 inches. Toe walls shall also be included along the bottom of the channel with a minimum depth of 24 inches for clay soils and 36 inches for sandy soils.
- Weep holes shall be used to relieve hydrostatic pressure behind lined channel sections. The specific type, size, and placement of the weep holes shall be based on the recommendations of the geotechnical report.

- Where construction is to take place under muddy conditions or where standing water is present, a seal slab of Class C concrete shall be placed in the channel bottom prior to placement of the concrete slope paving.
- Control joints shall be provided at a maximum spacing of 25 feet. A sealing agent shall be utilized to prevent moisture infiltration at control joints.

8.3.3 Rip-Rap

Rip-rap consists of rock or broken concrete pieces with a minimum dimension of about six inches and a maximum dimension of 18 to 24 inches. Rip-rap is normally hand-placed as a layer which extends 18 inches below the finished channel grade. Minimum requirements for rip-rap are as follows.

- The minimum mat thickness shall be 18 inches.
- Well-graded blocks weighing from 40 pounds to 265 pounds shall be used.
- The maximum steepness of slopes protected by rip-rap shall be 2 horizontal to 1 vertical.
- Filter fabric bedding is required in areas where rip-rap is placed on sandy or silty soils. On cohesive clay soils with very little sand content (less than 20-percent sand), filter fabric is not required.

Sacks of ready-mix concrete may not be used as rip-rap because lack of gradation allows water penetration and undermining of the soil under the installation.

8.3.4 Acceptable Velocities for Various Slope Treatments

The maximum allowable velocity in open channels and at bridges or culverts shall be analyzed for the design storm event. As shown in Table 8-2, the maximum allowable velocity is related to the type of channel, the slope treatment, and the soil structure throughout the open channel section. If the maximum velocities listed in this table are exceeded during the design storm event, then the channel design shall be modified until acceptable velocities are attained.

TABLE 8-2: MAXIMUM ALLOWABLE VELOCITIES IN OPEN CHANNELS

Soil Description	Slope Treatment	Maximum Velocity (feet per second)
Fine Sand	None	1.50
Sandy Loam	None	1.75
Silt Loam	None	2.00
Clay Loam	None	2.50
Stiff Clay	None	3.75
Sandy Soils (Easily Eroded)	Grass	4.00
Clay Soils (Erosion-Resistant)	Grass	5.00
Sandy Soils (Easily Eroded)	Rip-Rap	6.00
Clay Soils (Erosion Resistant)	Rip-Rap	8.00
Sandy Soils (Easily Eroded)	Concrete	8.00
Clay Soils (Erosion Resistant)	Concrete	10.00
Bridges and Culverts	----	8.00

8.4 REQUIREMENTS FOR CHANNEL BENDS AND CONFLUENCES

Erosion protection is required for all channel bends with a radius of curvature (measured along the channel centerline) less than three times the top width of flow in the channel. When required, erosion protection must extend along the outside bank of the bend and at least 20 feet upstream and downstream of the tangent points. Slope protection on the channel bottom and the inside bank is required only if anticipated flow velocities are above non-erosive levels. Exhibit 8-1 illustrates the erosion protection requirements for channel bends.

Exhibit 8-2 illustrates the minimum requirements for erosion protection and channel lining at the confluence of two open channels. Table 8-3 may be used to determine whether erosion protection is needed given the angle of intersection between the channels and the anticipated 25-year flow velocity in the tributary channel. Table 8-4 summarizes the minimum extent of erosion protection upstream and downstream of the confluence.

TABLE 8-3: MINIMUM EROSION PROTECTION FOR CHANNEL CONFLUENCES

25-Year Velocity in Tributary Channel (feet per second)	Angle of Intersection (θ)	
	15 to 45 degrees	45 to 90 degrees
≥ 4.0	Protection Required	Protection Required
2.0 – 4.0	No Protection Required	Protection Required
≤ 2.0	No Protection Required	No Protection Required

TABLE 8-4: MINIMUM EXTENT OF EROSION PROTECTION AT CONFLUENCES

Location	Minimum Distance (feet)
a	20
b	larger of 50 or $0.75T_m/\tan \theta$
c	20

For both bends and confluences, the top edge of erosion protection shall extend at least as high as the 25-year design water surface elevation in the channel or two-thirds of the way up the channel side slopes, whichever is lower. A healthy grass cover must be established on the channel slope above the concrete lining.

8.5 REQUIREMENTS FOR STORM SEWER OUTFALLS

Storm sewer outfalls shall be designed and constructed in accordance with Exhibits 6-1 and 6-2.

8.6 CHANNEL BACKSLOPE DRAIN SYSTEMS

Backslope drain systems intercept sheet flow which otherwise would flow over the banks of drainage channels leading to erosion of the side slopes. The following minimum requirements shall be applied to all backslope drainage systems.

- The minimum backslope drain pipe diameter shall be 24 inches.
- The maximum spacing between backslope drains shall be 600 feet.
- The center-line of the backslope drainage swale shall be located five feet inside the channel right-of-way (ROW) line when 20-foot maintenance berms are used. When a 30-foot maintenance berm width is used, the backslope drainage swale shall be located 7.5 feet inside the ROW line.
- The minimum depth for backslope drainage swales shall be 0.5 feet. The maximum depth shall be two feet.

- The minimum invert slope for backslope drainage swales shall be two-percent.
- The maximum side slope for backslope drainage swales shall be 1.5 horizontal to one vertical (1.5:1).

8.7 INTERCEPTOR STRUCTURES

Interceptor structures are designed to convey storm water from secondary drainage facilities such as roadside ditches into receiving channels. The main purpose of the interceptor is to prevent storm water runoff from flowing over the channel banks and down the channel side slopes. Exhibits 8-5 and 8-6 illustrate the basic configuration of a typical interceptor structure.

8.8 STORM WATER POLLUTION PREVENTION PLANS

Storm water pollution prevention plans shall be developed for all projects involving drainage improvements. These plans should focus primarily on the prevention of erosion and sediment deposition. Pollution control plans should be simple, easy to implement, and easy to maintain through the life of the construction project. Exhibit 8-7 illustrates the configuration for a rock berm, which is one of the most effective measures for preventing sediments from being carried into a creek or channel. The rock berm reduces flow velocities in small ditches, causing suspended sediments to settle out. Sediments accumulating in the area immediately upstream of the rock berm must be removed periodically in order to preserve the effectiveness of the berm and the hydraulic capacity of the ditch. A filter fabric fence is another effective measure for containing sediments.

8.9 SPECIAL ENERGY DISSIPATION STRUCTURES

Special energy dissipation structures such as baffled chute spillways shall be designed in accordance with procedures developed by the U.S. Bureau of Reclamation set forth in *Design of Small Dams* (U.S. Department of the Interior, Bureau of Reclamation, 19

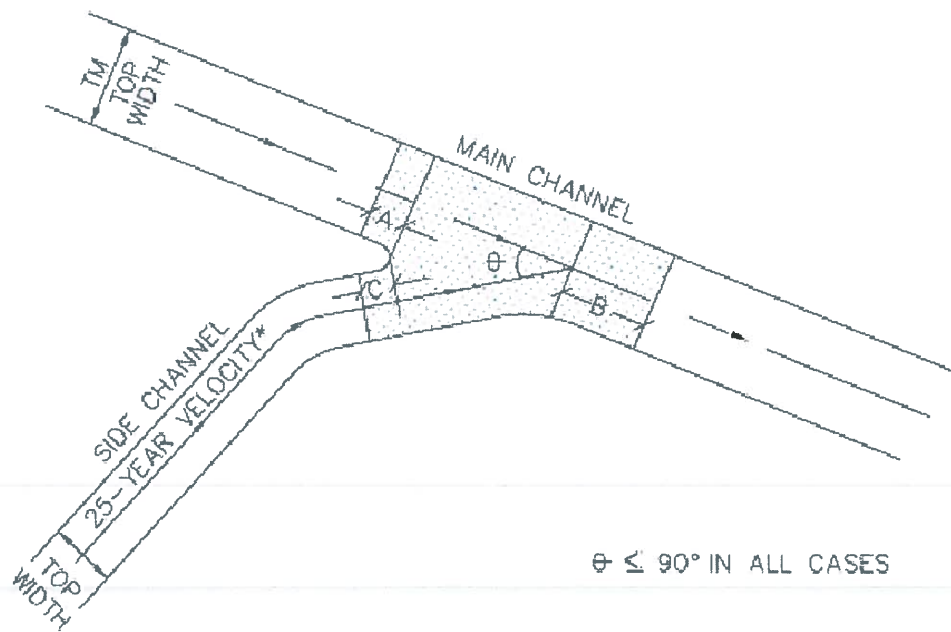

MINIMUM EXTENT OF EROSION PROTECTION

<u>LOCATION</u>	<u>DISTANCE (FT.)</u>	
A	20'	
B	LARGER OF 50' OR $0.75 \times TM \mid \tan \theta$	
C	20'	

<u>25-YEAR VELOCITY* IN SIDE CHANNEL (FEET PER SECOND)</u>	<u>ANGLE OF INTERSECTION, θ</u>	
	<u>15° - 45°</u>	<u>45° - 90°</u>
≥ 4.0 OR MORE	PROTECTION	PROTECTION
2.0 - 4.0	NO PROTECTION	PROTECTION
≤ 2.0	NO PROTECTION	NO PROTECTION

* NOTE:

25-YEAR VELOCITY IN SIDE CHANNEL
ASSUMING NO BACKWATER FROM MAIN CHANNEL.

SLOPE PROTECTION REQUIREMENTS
AT STREAM CONFLUENCES



DRAINAGE
CRITERIA
MANUAL

EXHIBIT #: 8-1
DATE: SEPTEMBER 2018

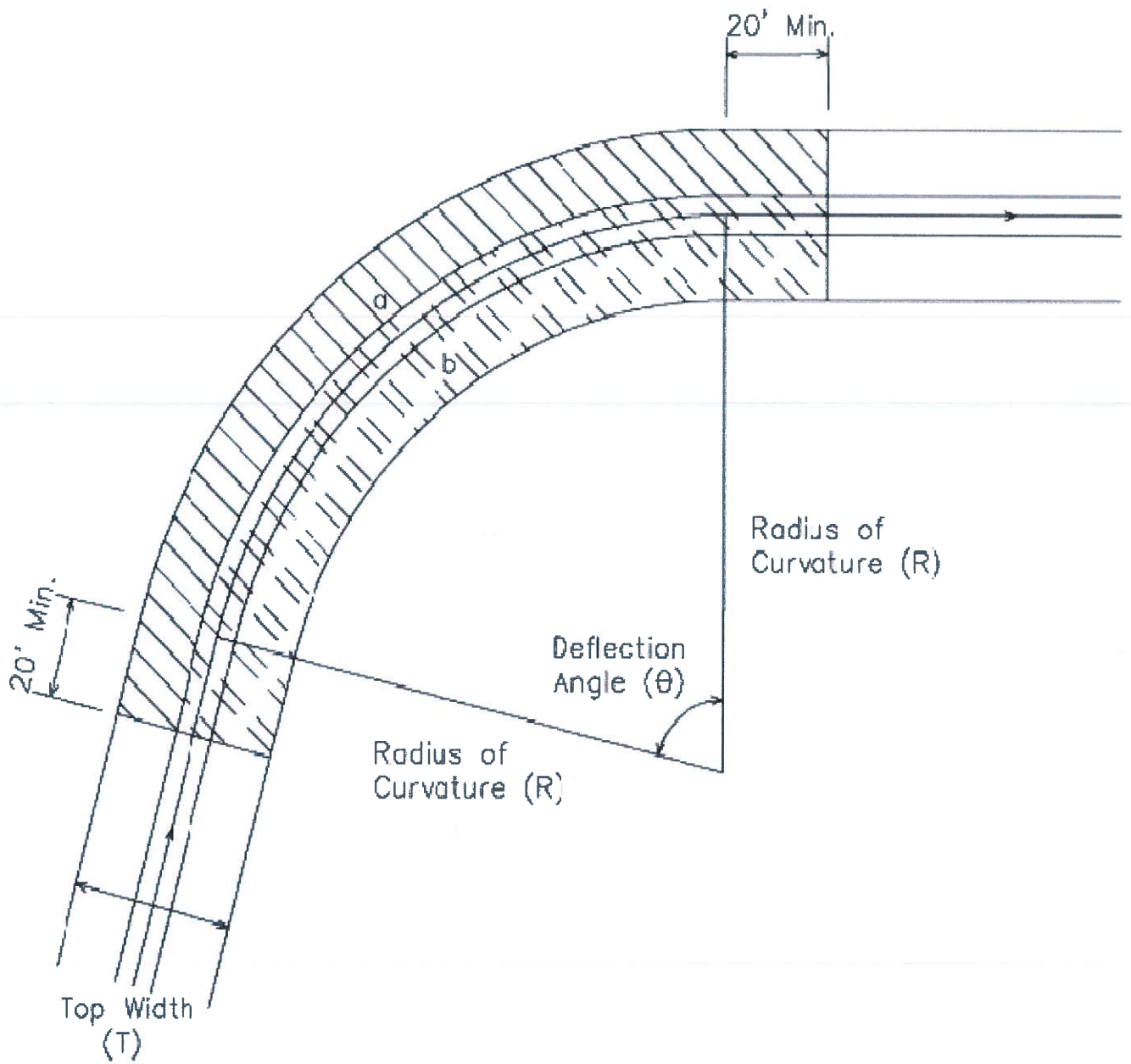

SLOPE PROTECTION REQUIREMENTS
AT CHANNEL BENDS



DRAINAGE
CRITERIA
MANUAL

EXHIBIT #: 8-2

DATE: SEPTEMBER 2018

1'-0" Above \bar{C} or Normal
Water Surface Elevation

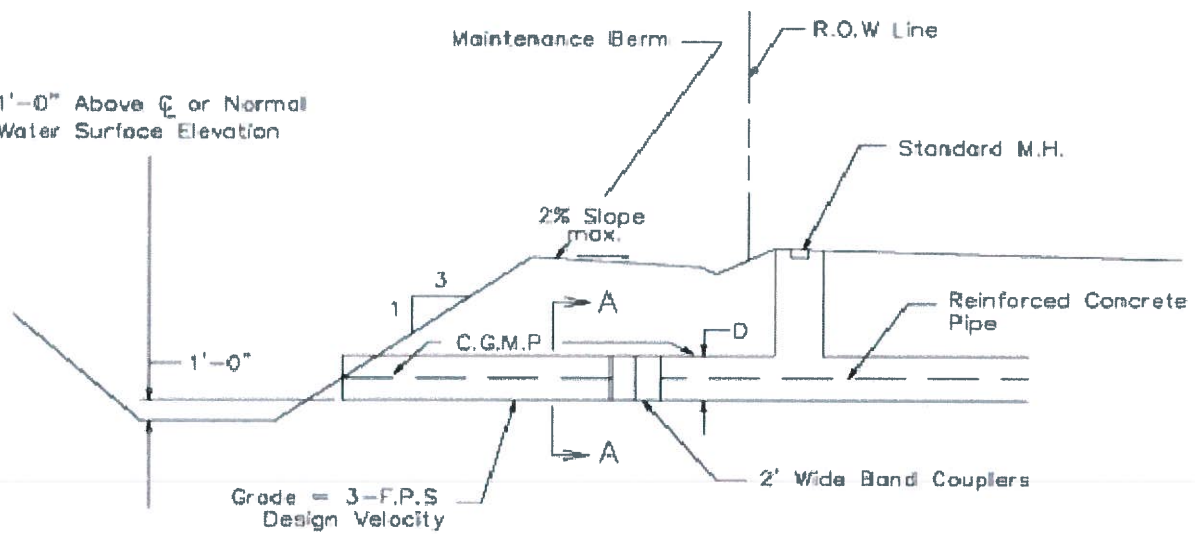

ELEVATION

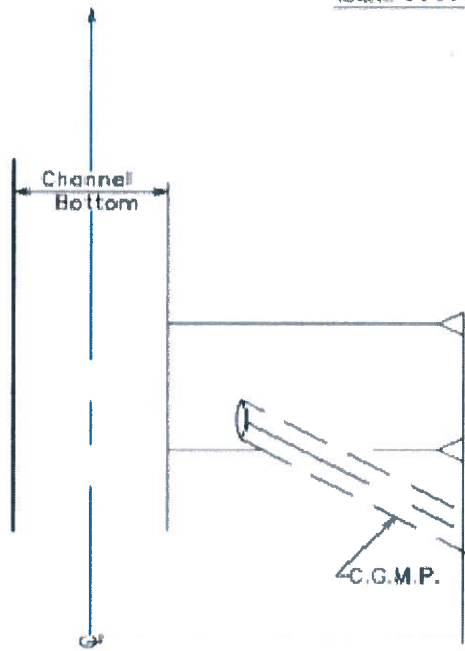

PLAN

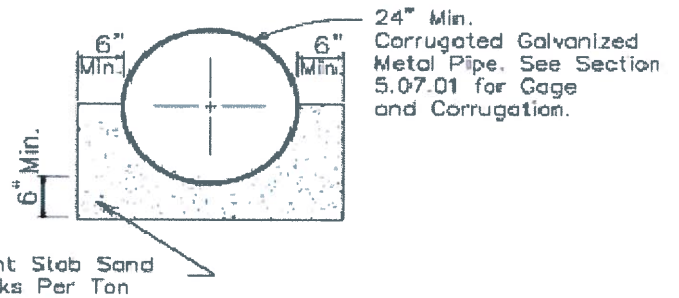

SECTION A-A

TYPICAL STORM SEWER OUTFALL STRUCTURE
(24-INCH TO 42-INCH)



DRAINAGE
CRITERIA
MANUAL

EXHIBIT #: 8-3

DATE: SEPTEMBER 2018

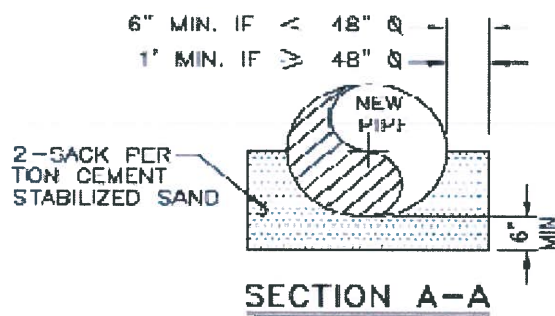
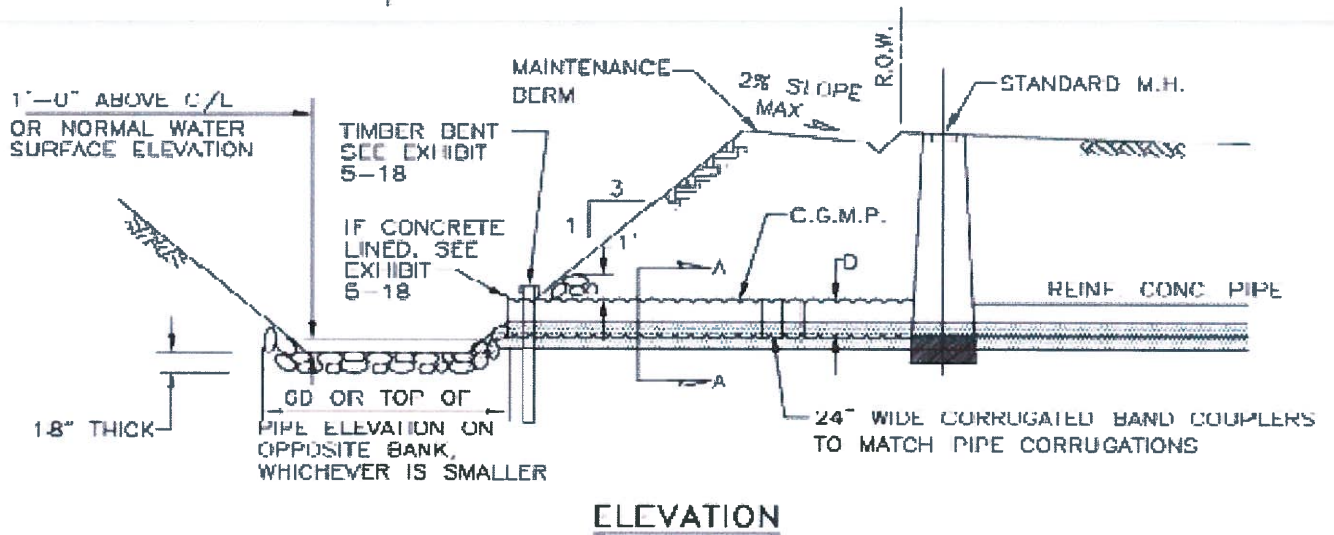
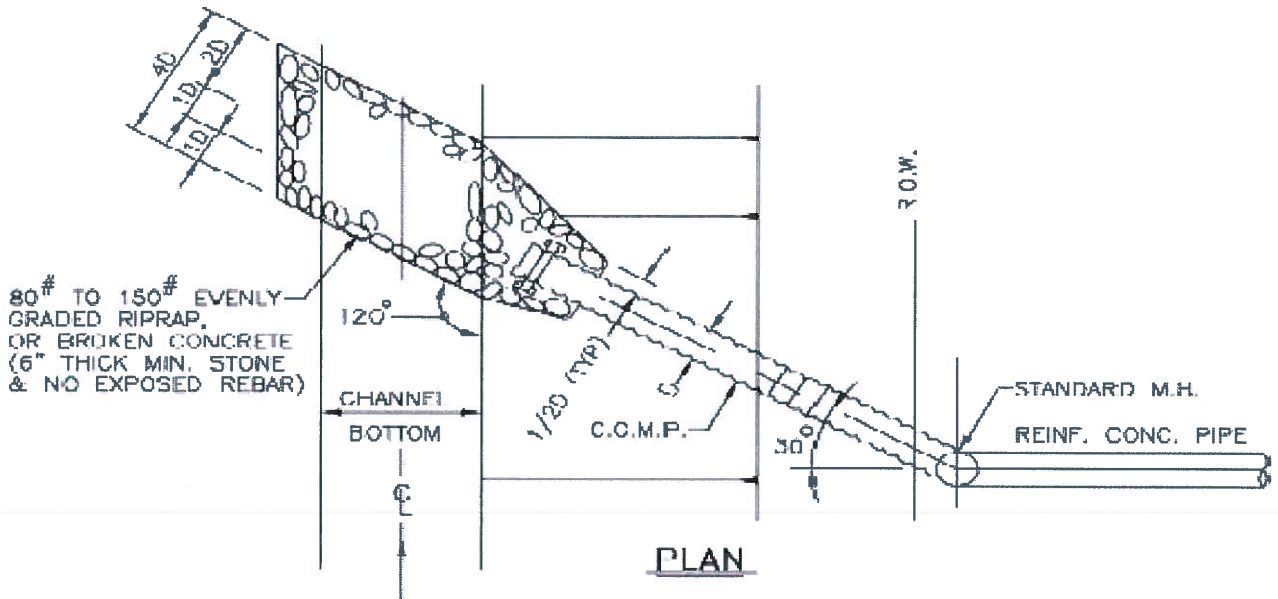

TYPICAL STORM SEWER OUTFALL STRUCTURE (48-INCH AND LARGER)



DRAINAGE CRITERIA MANUAL

EXHIBIT #: 8-4

DATE: SEPTEMBER 2018

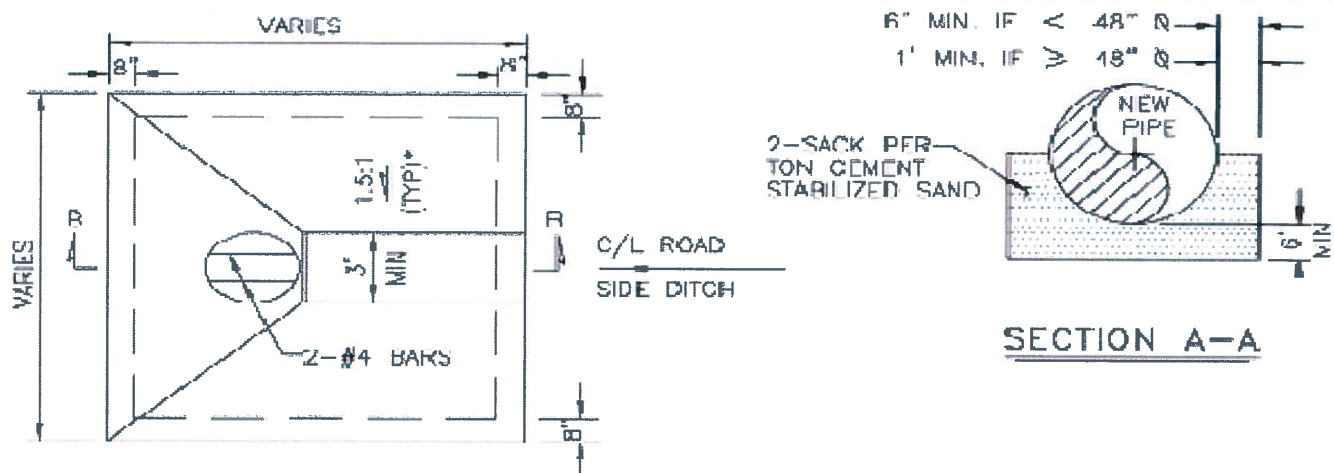

PLAN

* OR MATCH ROADSIDE DITCH SLOPE

SECTION A-A

C.G.M.P. SLOPE TABLE

PIPE DIAMETER	SLOPE
24 IN.	0.6%
30 IN.	0.4%
36 IN.	0.3%
42 IN.	0.3%
≥ 48 IN.	0.2%

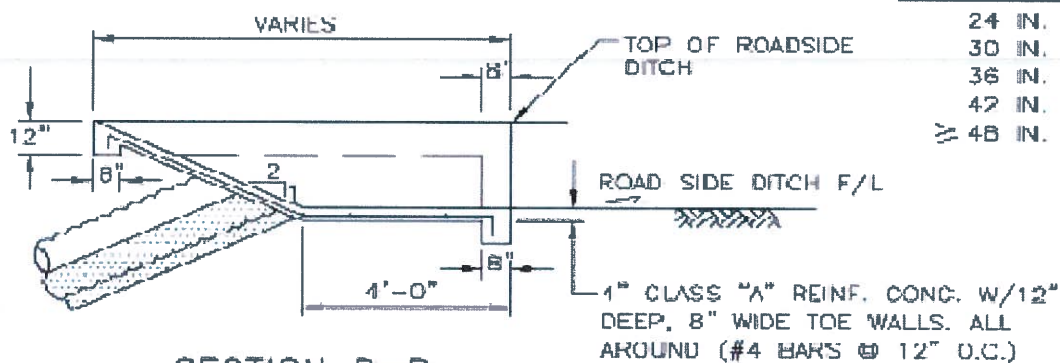

SECTION B-B

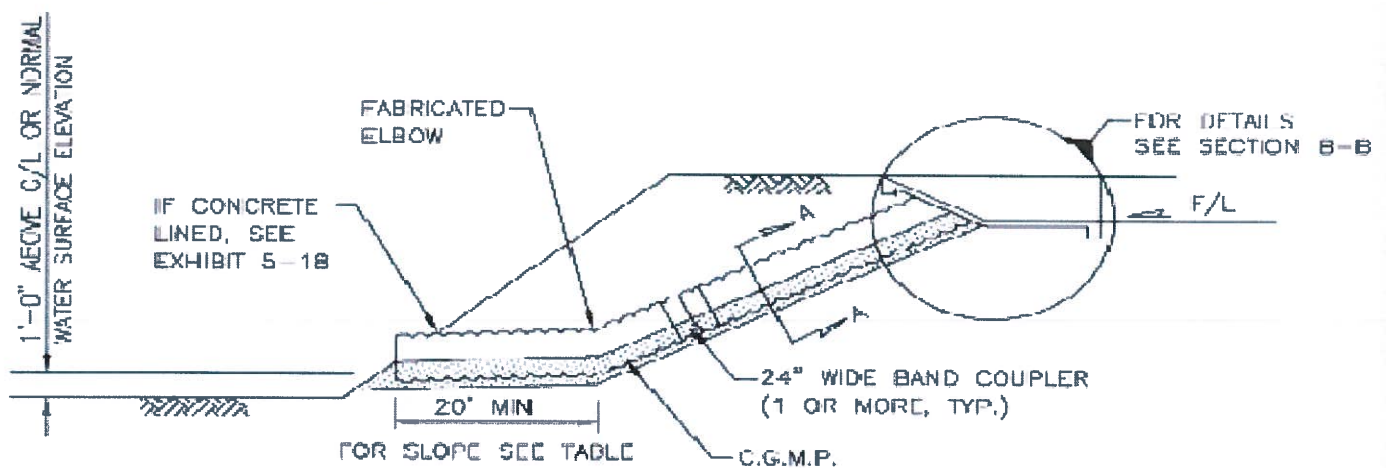

PROFILE

TYPICAL ROADSIDE DITCH INTERCEPTOR STRUCTURE



DRAINAGE CRITERIA MANUAL

EXHIBIT #: 8-5

DATE: SEPTEMBER 2018

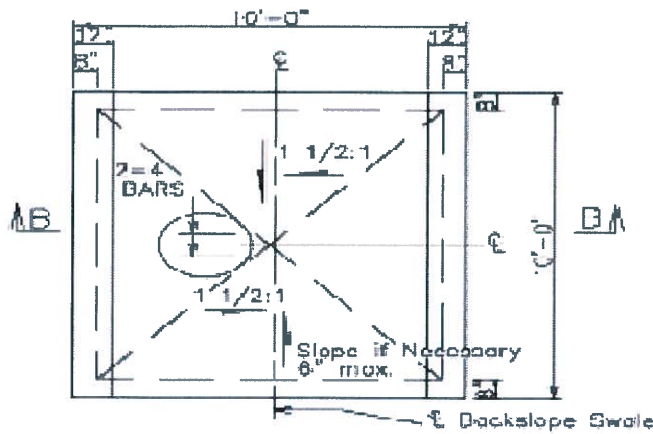

Pipe Dia.	Slope
24 in.	0.6%
36 in.	0.3%
48 in.	0.2%
60 in.	0.2%

PLAN

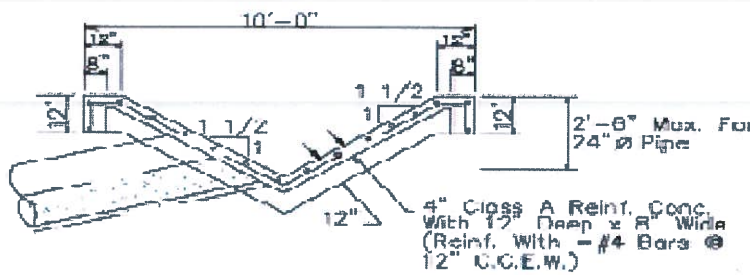

SECTION B-B

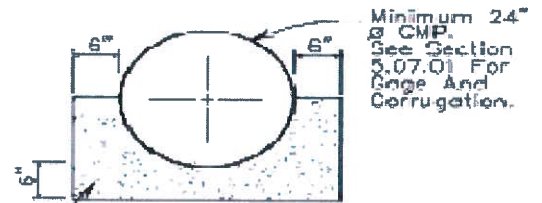

SECTION A-A

Cement Stab Sand
2 Sacks Per Ton

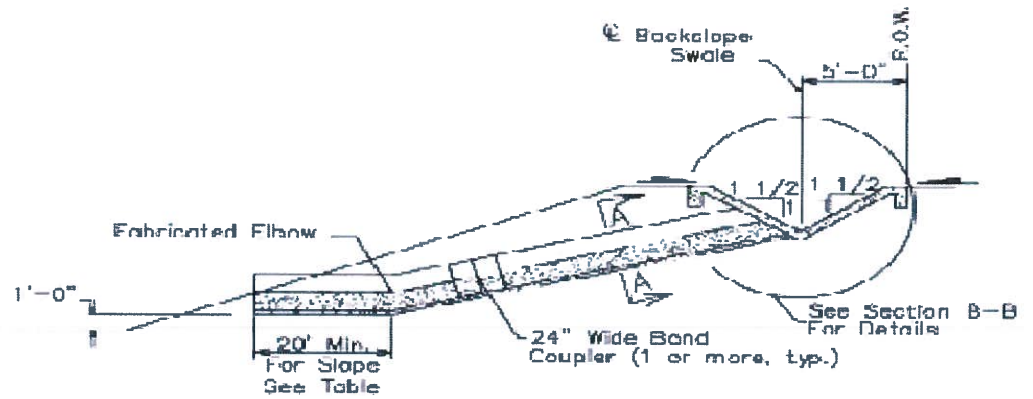

ELEVATION

TYPICAL BACKSLOPE INTERCEPTOR STRUCTURE



DRAINAGE
CRITERIA
MANUAL

EXHIBIT #: 8-6

DATE: SEPTEMBER 2018

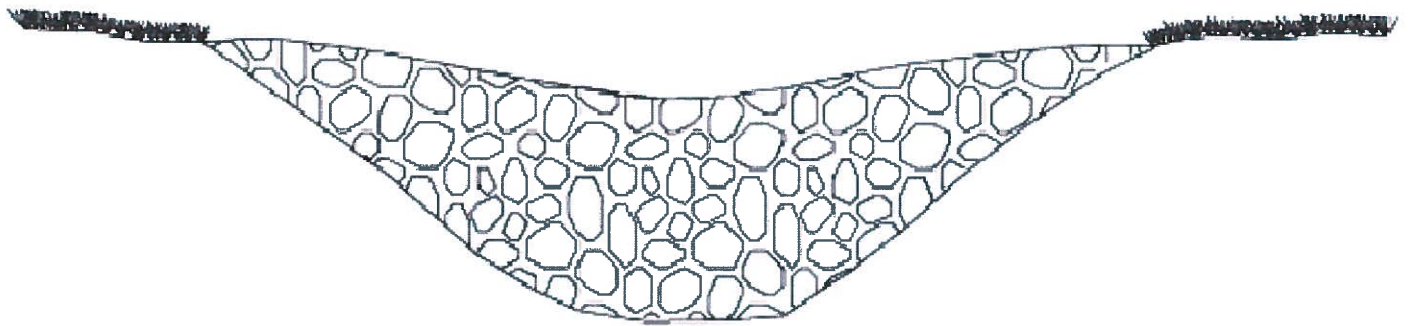

ROCK CHECK DAM

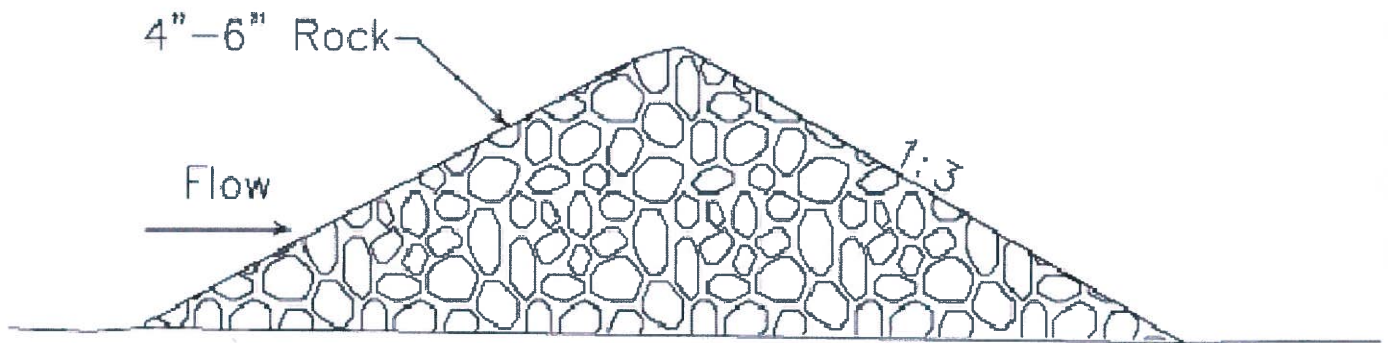

ROCK CHECK DAM CROSS-SECTION

TYPICAL ROCK CHECK DAM



DRAINAGE
CRITERIA
MANUAL

EXHIBIT #: 8-7

DATE: SEPTEMBER 2018

APPENDIX A. DRAINAGE DISTRICT NO. 7 STANDARDS

Detail 1: Typical channel concrete lined 4" side wall standard detail

Detail 2: Typical channel concrete lined 6" side wall standard detail

Detail 3: Concrete lined channel pipe entrance standard detail

Detail 4: Concrete lined channel box entrance standard detail

Detail 5: Concrete lined channel swale ditch entrance standard detail

Detail 6: Earthen channel small pipe entrance standard detail

Detail 7: Earthen channel small box entrance standard detail

Detail 8: Earthen channel large pipe entrance standard detail

Detail 9: Earthen channel large box entrance standard detail

Detail 10: Earthen channel deep pipe entrance standard detail

Detail 11: Earthen channel deep box entrance standard detail

Detail 12: Earthen channel swale ditch entrance standard detail

Detail 13: Headwall/Liner tie-in (pipe) standard detail

Detail 14: Headwall/Liner tie-in (box) standard detail

Detail 15: Hurricane flood protection levee typical fence detail

Detail 16: Concrete lined channel remove and replace patch

Detail 17: Concrete lined channel sidewall over 10 feet in length

Detail 18: Concrete lined channel typical spillway section

Detail 19: Directional/Direct pipe bore (HDD) Hurricane Flood Protection Levee (HFPL)

Detail 20: Minor levee/road repair

Detail 21: Minor levee repair wall section-slope

Detail 22: Minor HFPL repair wall section, wall section-level

Detail 23: Typical road section-levee crown

Detail 24: Horizontal/Directional bore concrete/earthen channel

Detail 25: Horizontal/Directional bore HFPL vertical wall / sheetpile

Detail 26: Typical concrete ramp

Detail 27: Additional sideslope pier reinforcement

Detail 28: Typical protection slab

TYPICAL CONCRETE LINED DITCH

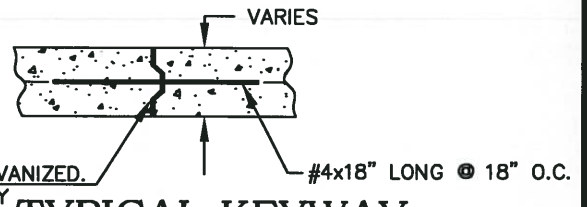
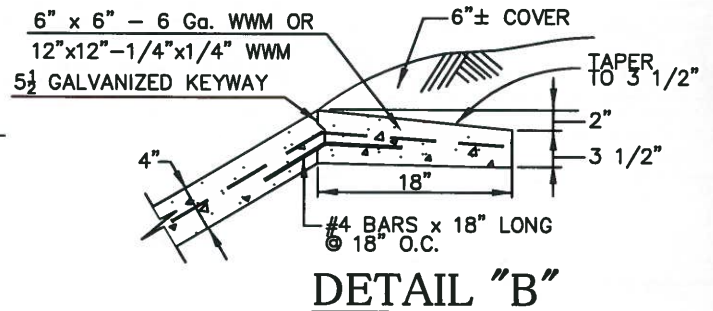
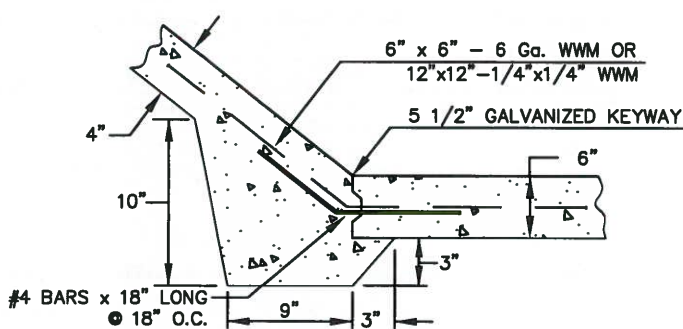
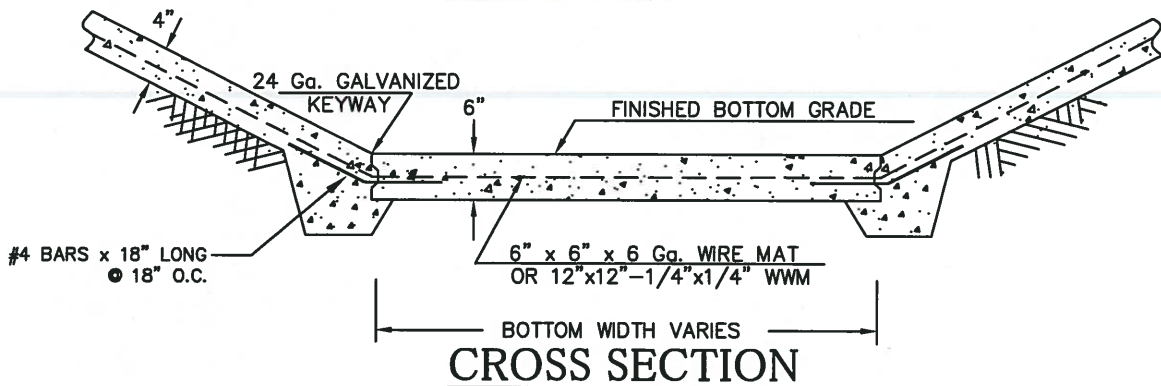
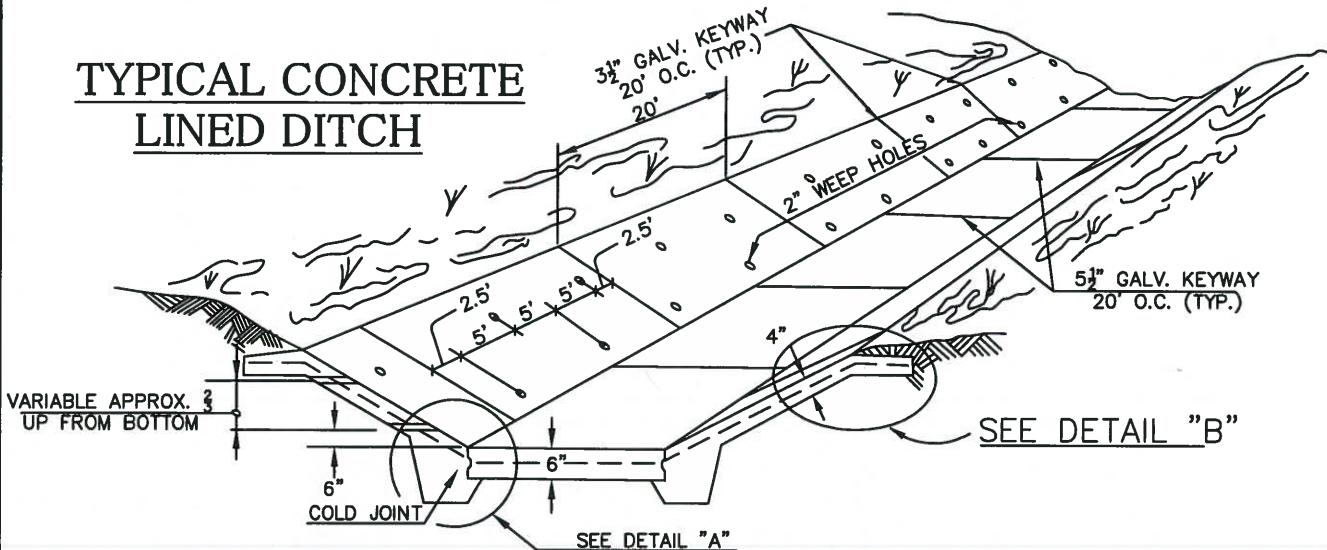

GENERAL NOTES:

1. **CONCRETE** - CONCRETE LINING SHALL CONTAIN A MINIMUM 4 1/2 SACK CEMENT PER CUBIC YARD OF TOTAL MIXTURE. MINIMUM COMPRESSIVE STRENGTH OF 2,500 PSI AT 28 DAYS. BOTTOM CONCRETE SHALL CONSIST OF 1" NOMINAL SIZE AGGREGATE MIX WITH BROOMED FINISH. SIDE SLOPE SHALL CONSIST OF 1/2" NOMINAL SIZE AGGREGATE MIX. AN OVERSANDED MIX MAY BE USED ON SIDE SLOPE WALLS WITH BROOMED FINISH. FORMS MAY BE REMOVED WHEN CONCRETE HAS AGED 24 HRS. MINIMUM.
2. **KEYWAYS** - SHALL BE FORMED USING 5 1/2" GALVANIZED KEYWAYS AND SIDE SLOPE SHALL BE FORMED USING 3 1/2" GALV. KEYWAYS, STAGGERED 10' FROM BOTTOM KEYWAY.
3. **WIRE MAT** - SHALL CONSIST OF 6"x6"-6 GA. OR 12"x12"-1/4"x1/4" WWM WITH ALL WIRE/REBAR TO BE TIED.
4. **DOWELS** - ALL DOWELS ARE TO BE NO. 4 (1/2" DIA.) x 18" LONG @ 18" O.C.
5. **FINAL DRESS** - UPON PROJECT COMPLETION, ENTIRE AREA IS TO BE DRESSED DOWN AND SEEDED. PROJECT SITE SHALL BE SEEDED WITH BERMUDA AT A RATE OF 3 LBS. PER 1,000 SQ. FT. OR 130 LBS. PER ACRE.

TYPICAL CHANNEL CONCRETE LINED-4" SIDE WALL STANDARD DETAIL

DGN. BY: R.J. MITCHELL

DWN. BY: BSL

CHECKED: R.J. MITCHELL

REVISED: 01/23/14

DETAIL #: 1



TYPICAL CONCRETE LINED DITCH

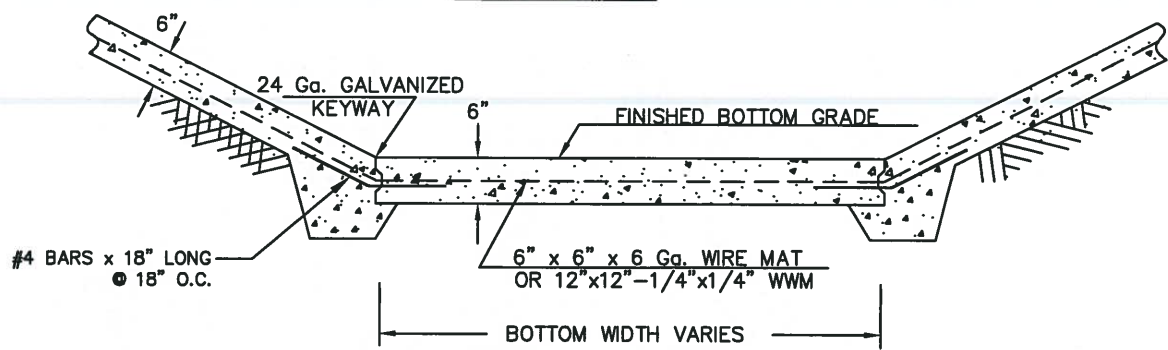
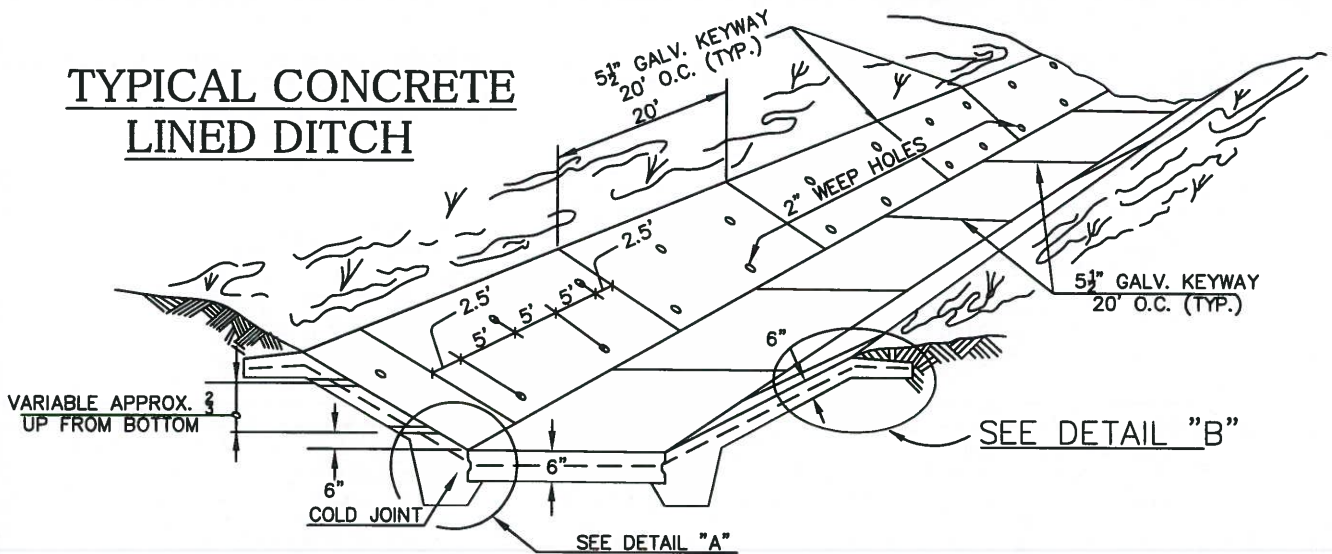

CROSS SECTION

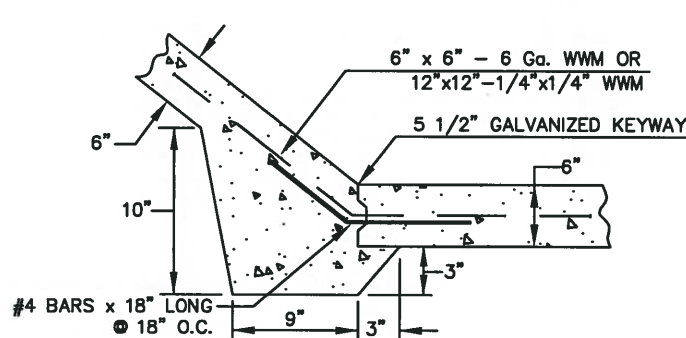

DETAIL "A"

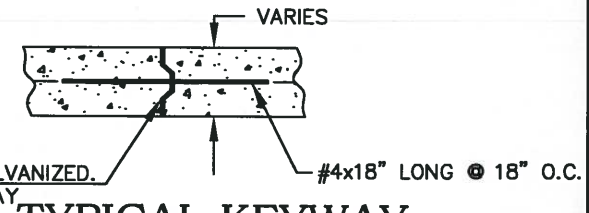
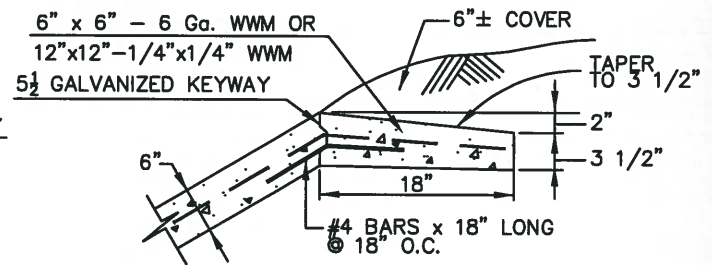

TYPICAL KEYWAY

GENERAL NOTES:

1. **CONCRETE** - CONCRETE LINING SHALL CONTAIN A MINIMUM 4 1/2 SACK CEMENT PER CUBIC YARD OF TOTAL MIXTURE. MINIMUM COMPRESSIVE STRENGTH OF 2,500 PSI AT 28 DAYS. BOTTOM CONCRETE SHALL CONSIST OF 1" NOMINAL SIZE AGGREGATE MIX WITH BROOMED FINISH. SIDE SLOPE SHALL CONSIST OF 1/2" NOMINAL SIZE AGGREGATE MIX. AN OVERSANDED MIX MAY BE USED ON SIDE SLOPE WALLS WITH BROOMED FINISH. FORMS MAY BE REMOVED WHEN CONCRETE HAS AGED 24 HRS. MINIMUM.
2. **KEYWAYS** - SHALL BE FORMED USING 5 1/2" GALVANIZED KEYWAYS, STAGGERED 10' FROM BOTTOM KEYWAY.
3. **WIRE MAT** - SHALL CONSIST OF 6"x6"-6 GA. OR 12"x12"-1/4"x1/4" WWM WITH ALL WIRE/REBAR TO BE TIED.
4. **DOWELS** - ALL DOWELS ARE TO BE NO. 4 (1/2"DIA.) x 18" LONG @ 18" O.C.
5. **FINAL DRESS** - UPON PROJECT COMPLETION, ENTIRE AREA IS TO BE DRESSED DOWN AND SEEDED. PROJECT SITE SHALL BE SEEDED WITH BERMUDA AT A RATE OF 3 LBS. PER 1,000 SQ. FT. OR 130 LBS. PER ACRE.

TYPICAL CHANNEL CONCRETE LINED-6" SIDE WALL STANDARD DETAIL



DGN. BY:	R.J. MITCHELL
DWN. BY:	BSL
CHECKED:	R.J. MITCHELL
REVISED:	01/23/14
DETAIL #:	2

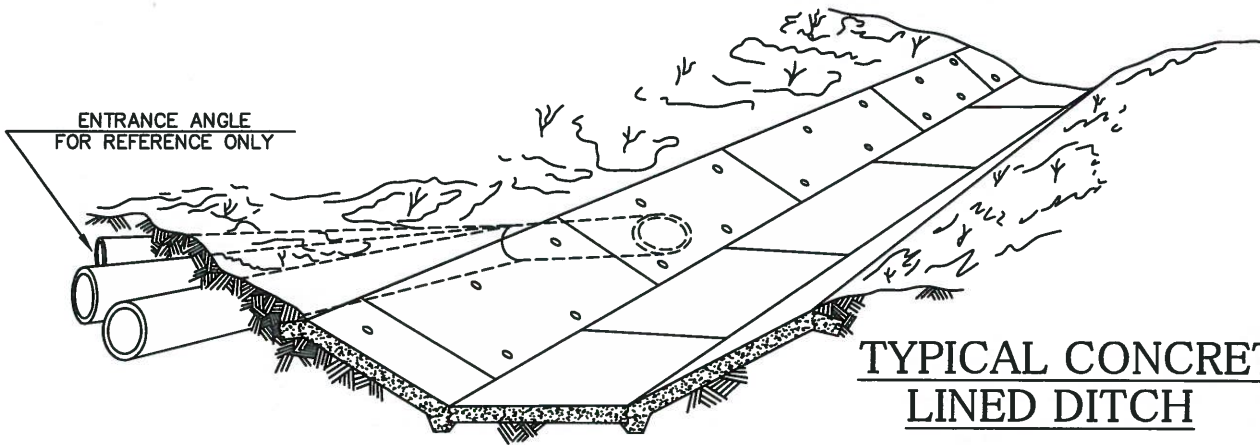

TYPICAL CONCRETE LINED DITCH

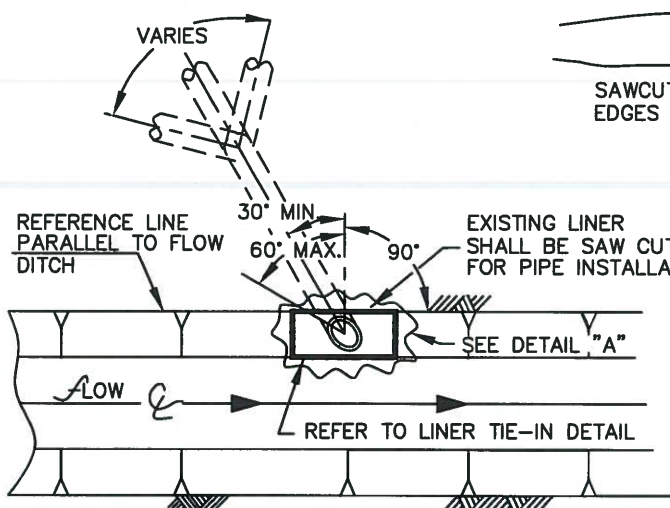

PLAN

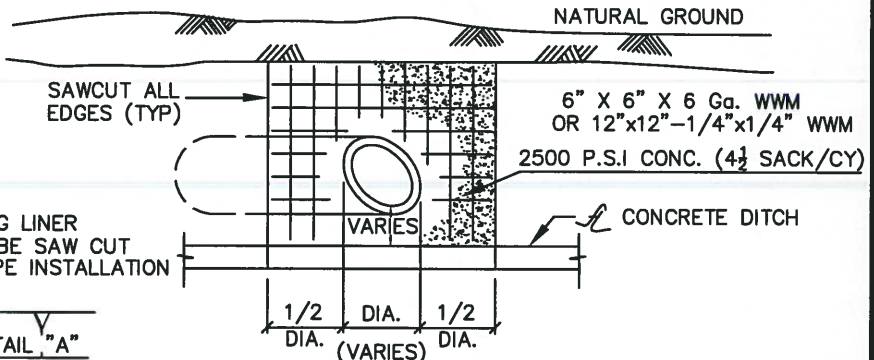

DETAIL "A"

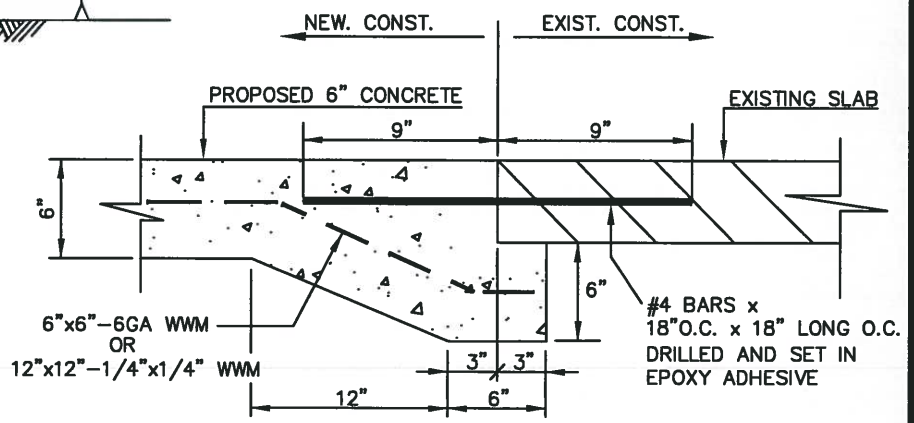

LINER TIE-IN DETAIL

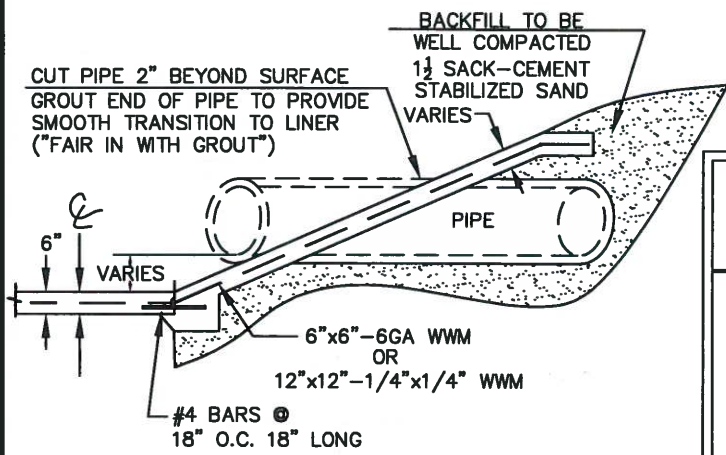

CROSS SECTION

(FOR USE IN JOINING NEW CONCRETE LINER TO EXISTING CONCRETE LINER FOR BOTTOM SLABS & SIDE SLABS)

**CONCRETE LINED CHANNEL
PIPE ENTRANCE
STANDARD DETAIL**

DGN. BY:	R.J. MITCHELL
DWN. BY:	CRW
CHECKED:	R.J. MITCHELL
REVISED:	01/23/14
DETAIL #:	3



ENTRANCE ANGLE FOR REFERENCE ONLY

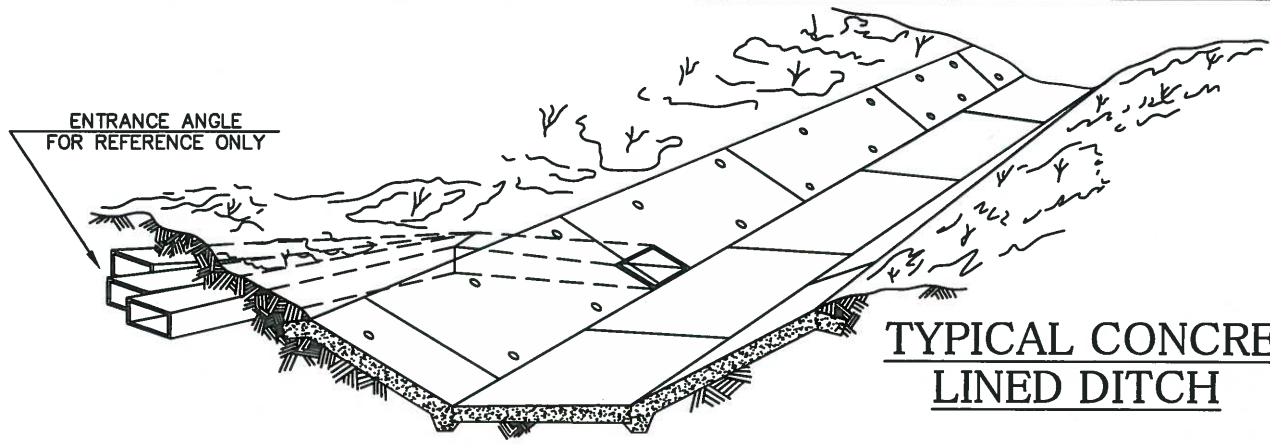

TYPICAL CONCRETE LINED DITCH

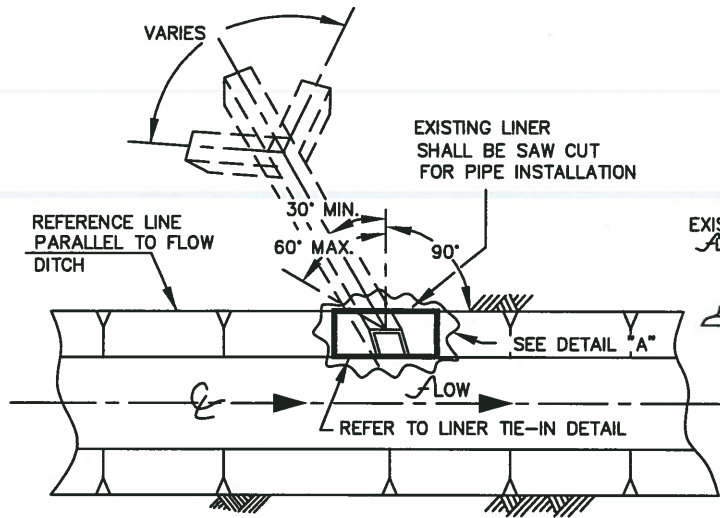

PLAN

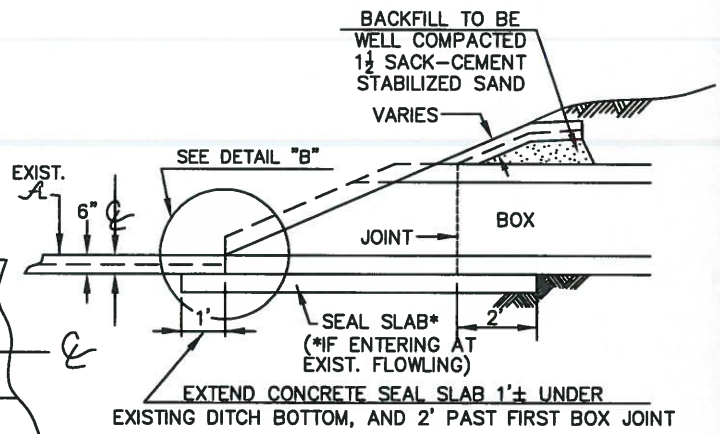

PROFILE

6" X 6" X 6 Ga. WIRE MAT
OR 12"x12"-1/4"x1/4" WWM
2500 P.S.I. CONC.
4 1/2 SACK/CY

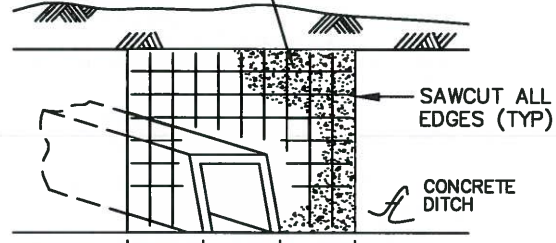

DETAIL "A"

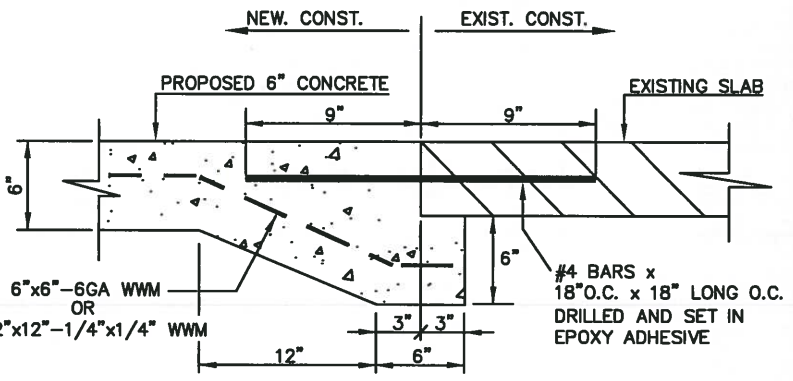

LINER TIE-IN DETAIL

(FOR USE IN JOINING NEW CONCRETE LINER TO EXISTING CONCRETE LINER FOR BOTTOM SLABS & SIDE SLABS)

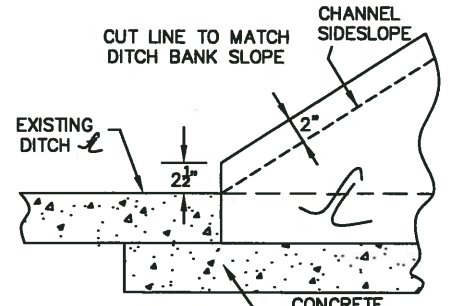

DETAIL "B"

CONCRETE LINED CHANNEL BOX ENTRANCE STANDARD DETAIL



DGN. BY:	R.J. MITCHELL
DWN. BY:	BSL
CHECKED:	R.J. MITCHELL
REVISED:	01/23/14
DETAIL #:	4

TYPICAL CONCRETE LINED DITCH

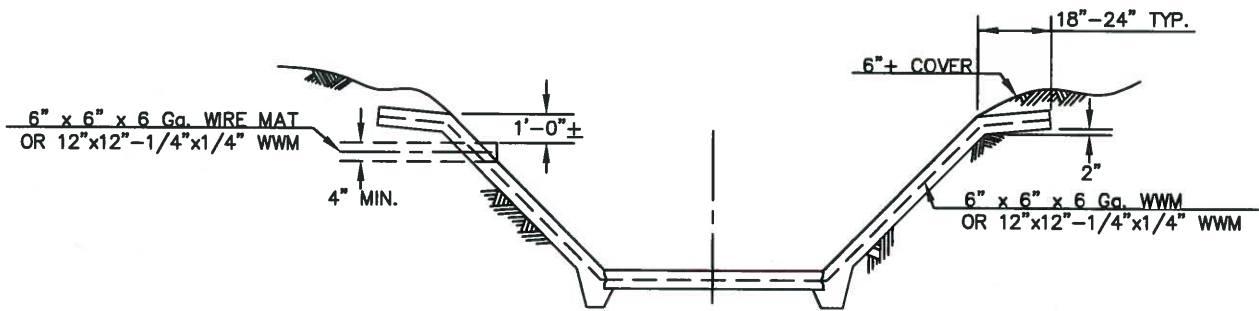
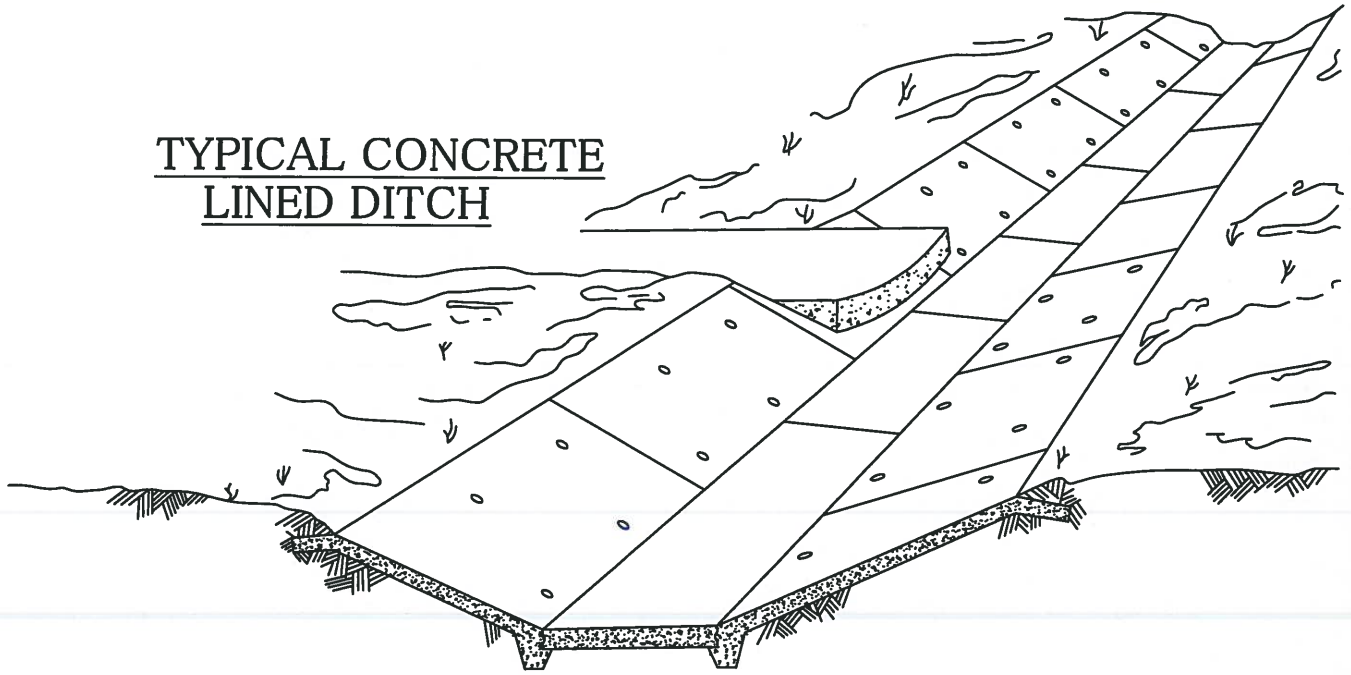

CROSS SECTION

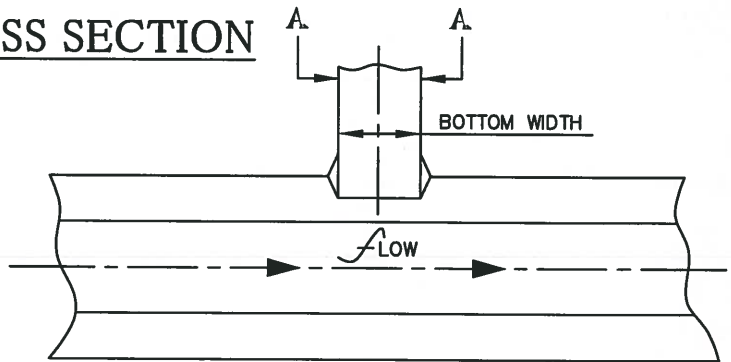

PLAN

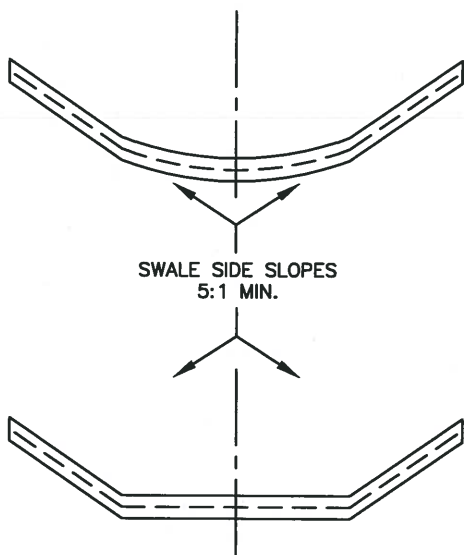

SECTION A-A

CONCRETE LINED CHANNEL SWALE DITCH ENTRANCE STANDARD DETAIL



DGN. BY: R.J. MITCHELL

DWN. BY: BSL

CHECKED: R.J. MITCHELL

REVISED: 01/23/14

DETAIL #: 5

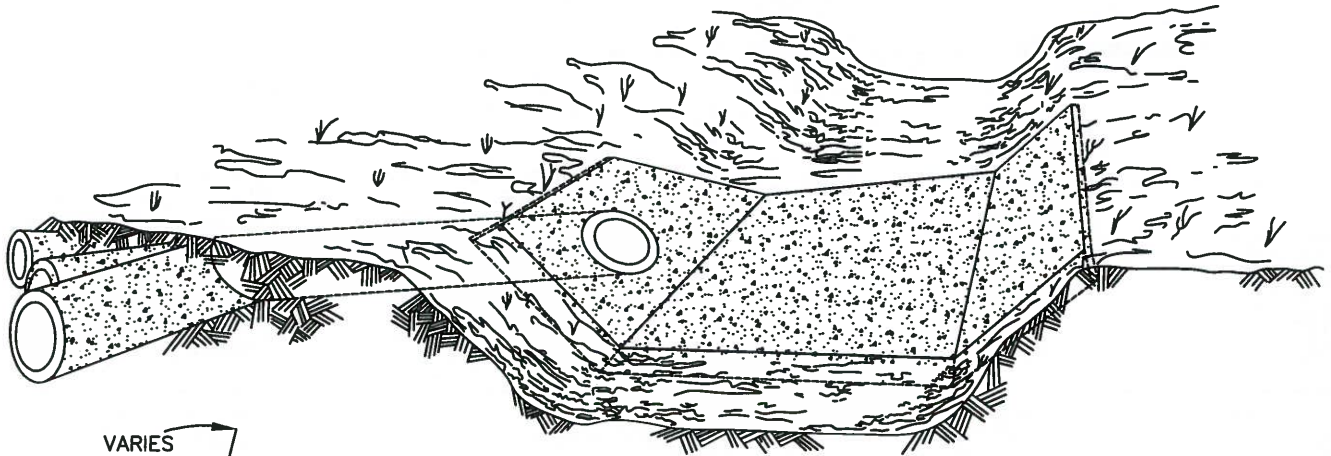

TYPICAL EARTHEN DITCH-SMALL CHANNEL

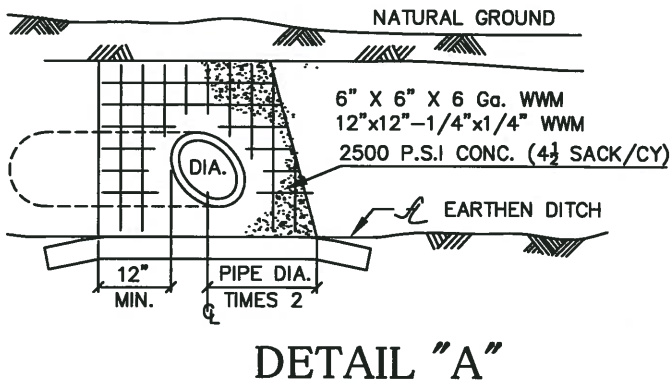
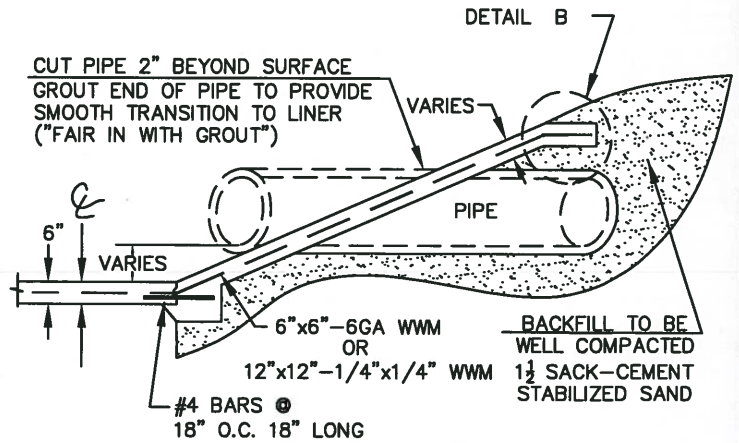
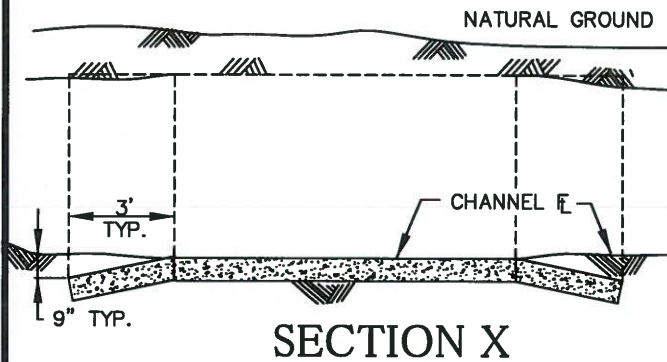
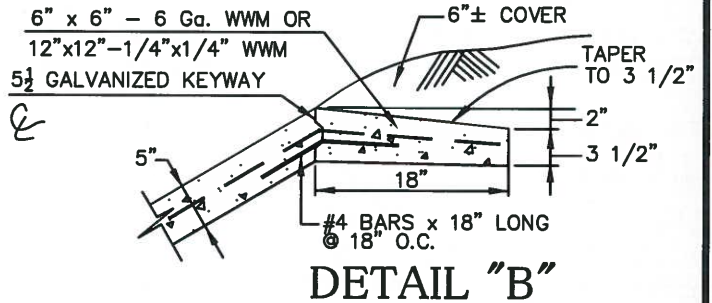
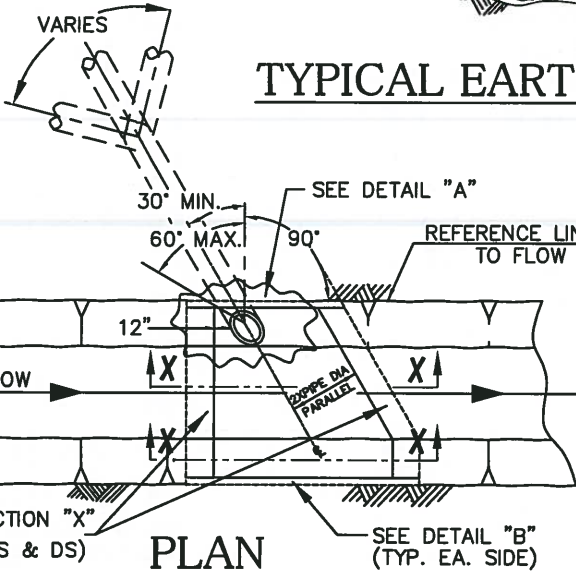

EARTHEN CHANNEL SMALL PIPE ENTRANCE STANDARD DETAIL

DGN. BY:	R.J. MITCHELL
DWN. BY:	BSL
CHECKED:	R.J. MITCHELL
FINAL CHECK:	EAL
REVISED:	09/01/08
DETAIL #:	6



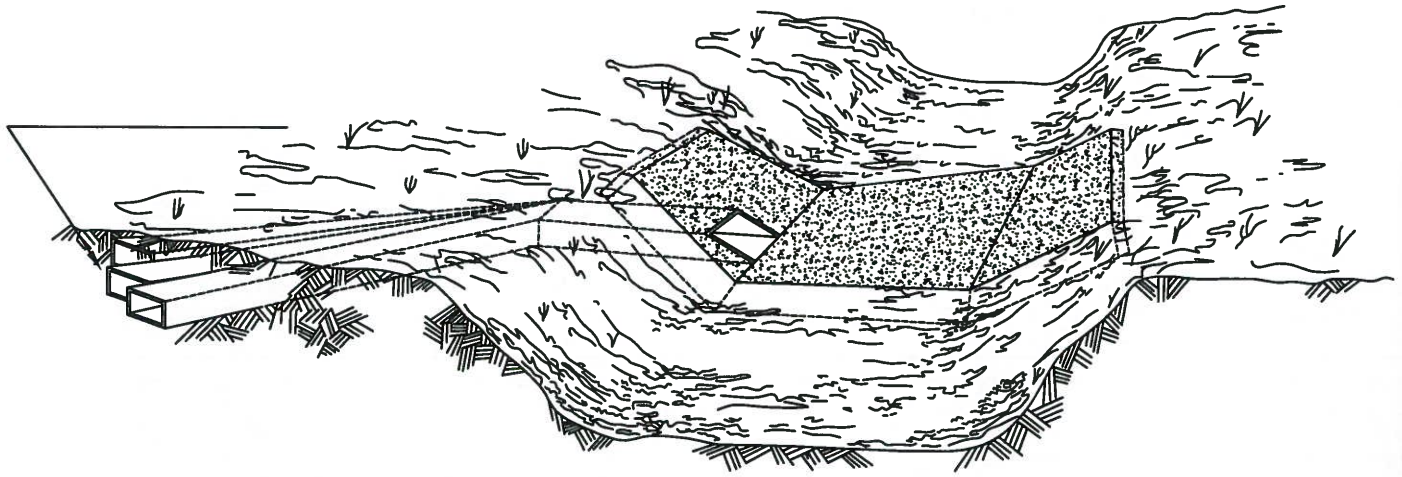

TYPICAL EARTHEN DITCH-SMALL CHANNEL

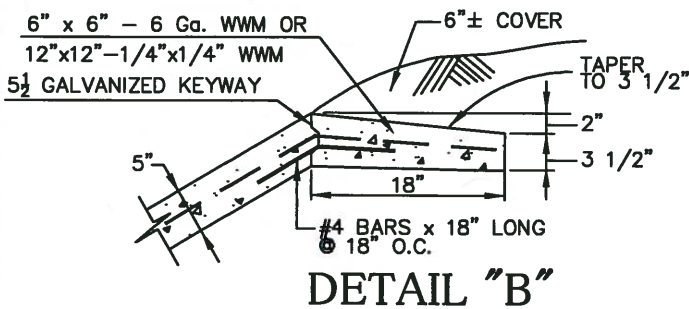
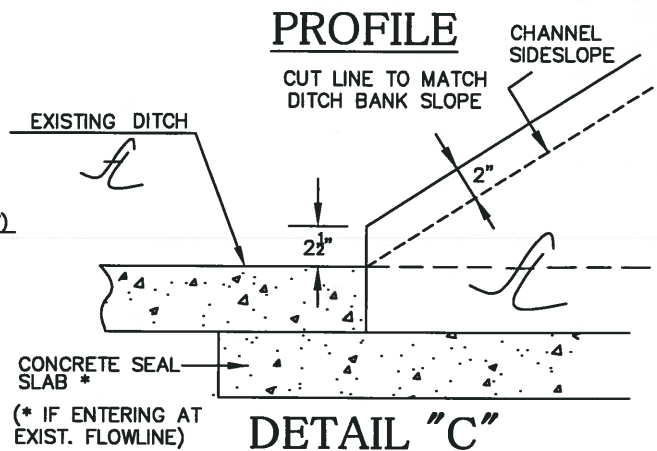
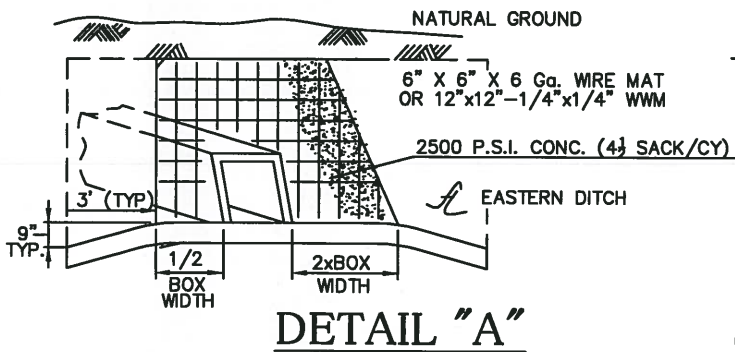
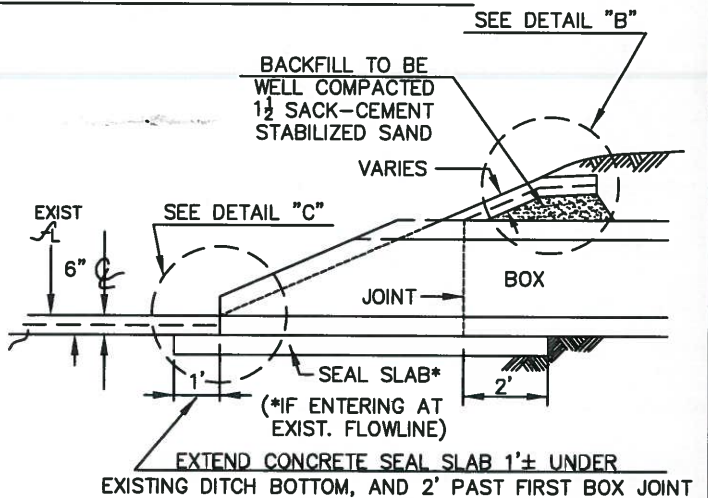
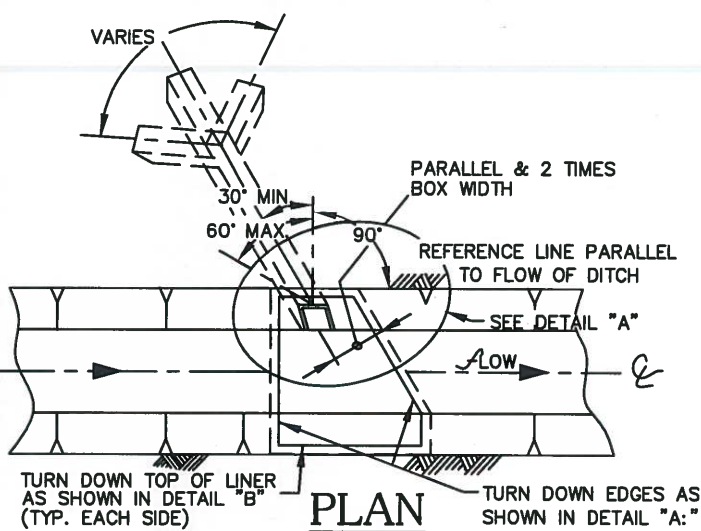

EARTHEN CHANNEL-SMALL BOX ENTRANCE STANDARD DETAIL



DGN. BY:	R.J. MITCHELL
DWN. BY:	BSL
CHECKED:	R.J. MITCHELL
FINAL CHECK:	EAL
REVISED:	09/01/08
DETAIL #:	7

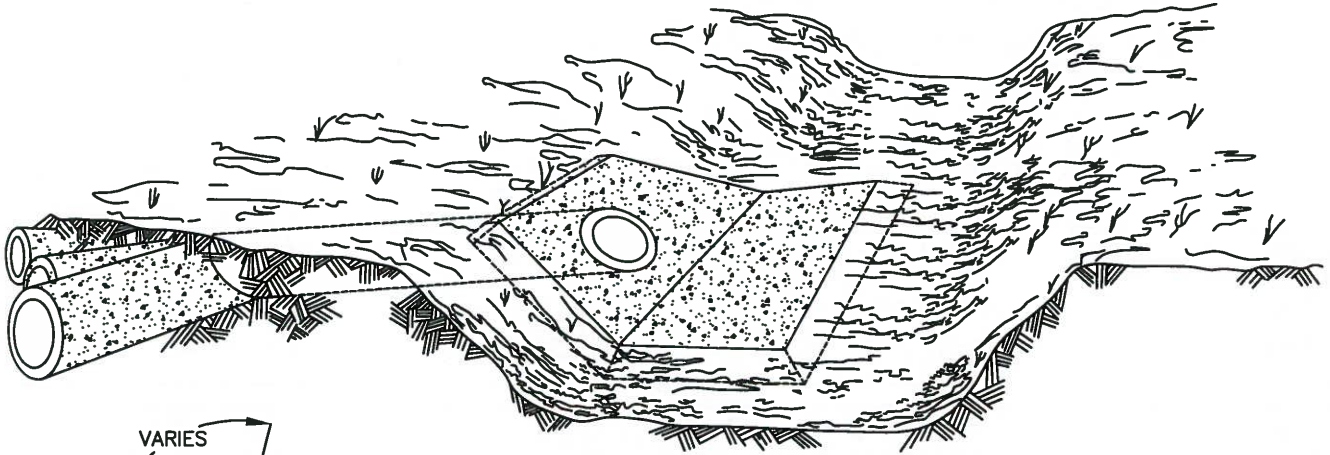

TYPICAL EARTHEN DITCH- LARGE CHANNEL DITCH

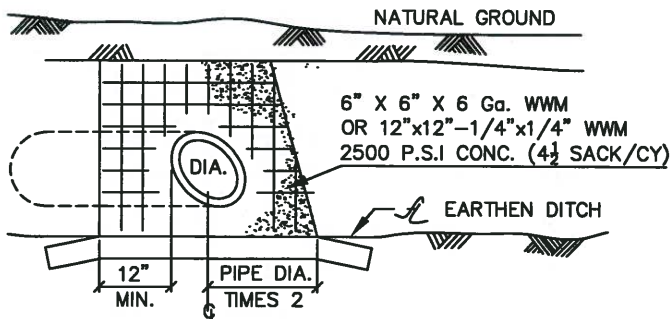
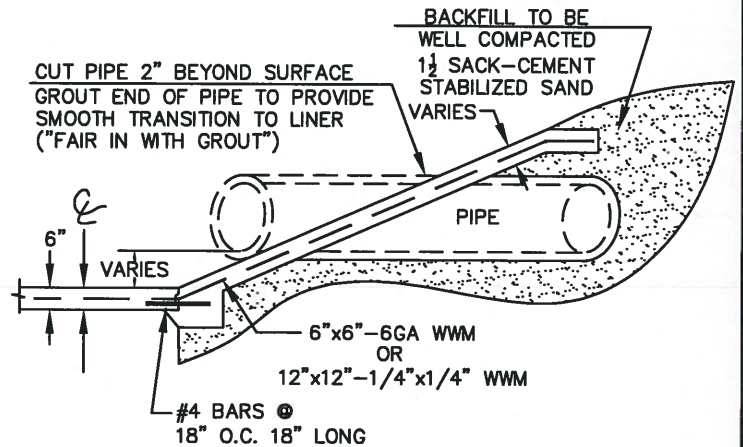
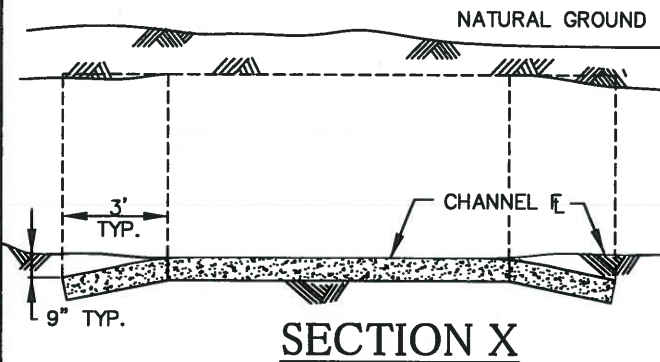
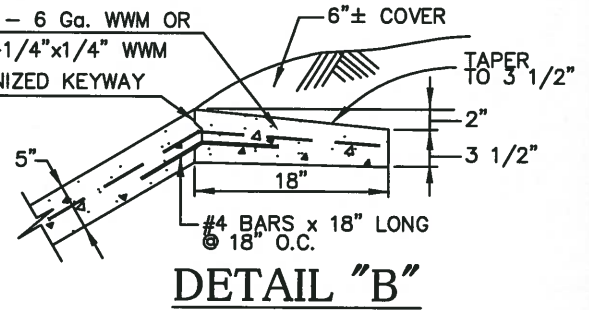
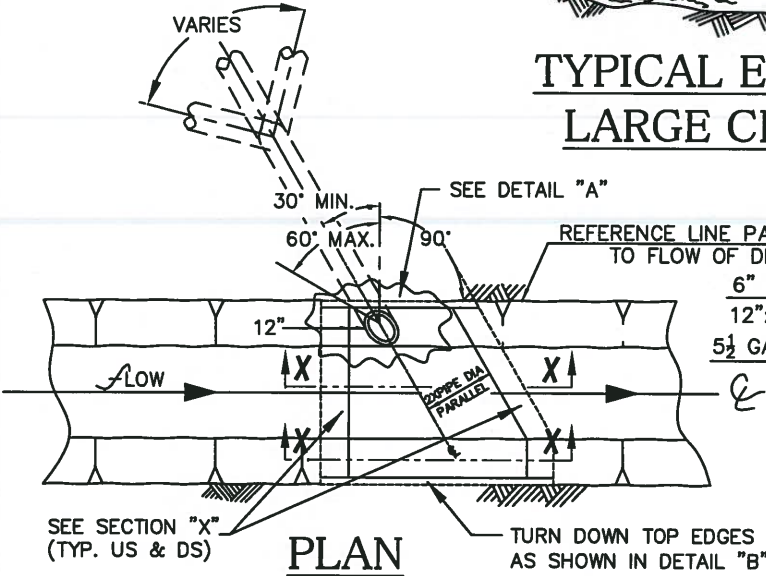

DETAIL "A"

EARTHEN CHANNEL-LARGE PIPE ENTRANCE STANDARD DETAIL



DGN. BY: R.J. MITCHELL

DWN. BY: BSL

CHECKED: R.J. MITCHELL

FINAL CHECK: EAL

REVISED: 10/17/11

DETAIL #: 8

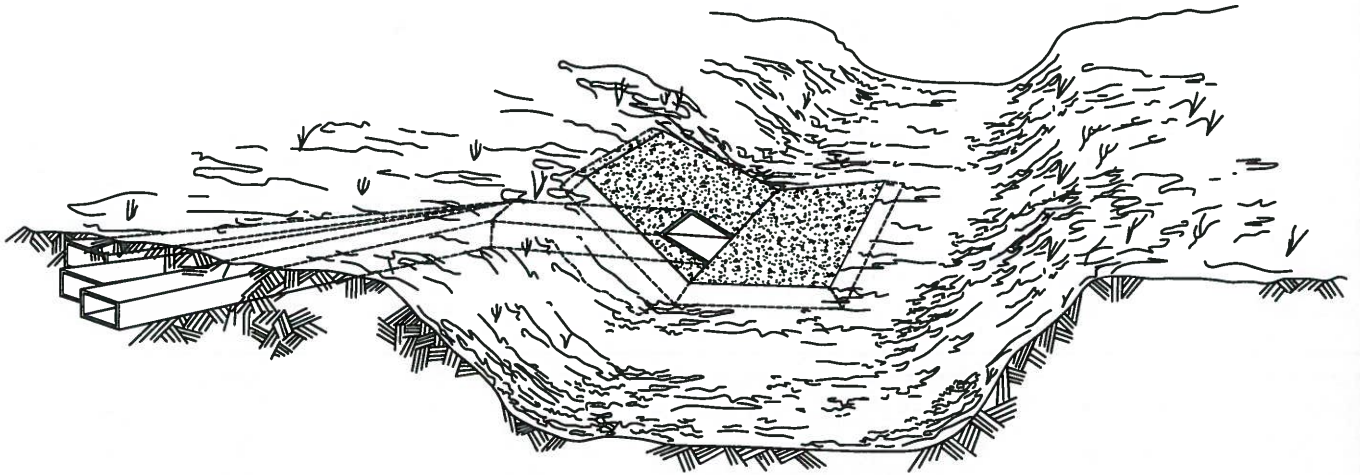

TYPICAL EARTHEN DITCH-LARGE CHANNEL

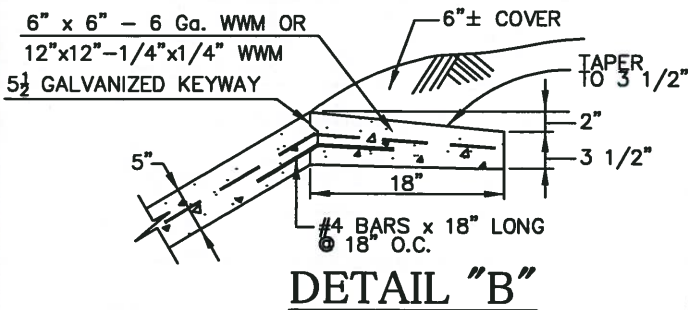
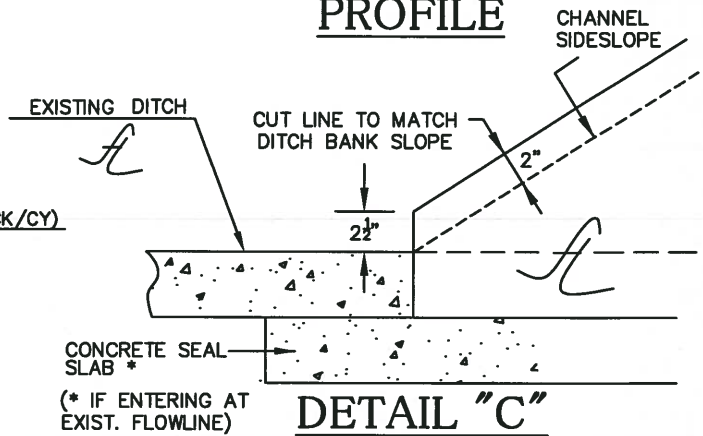
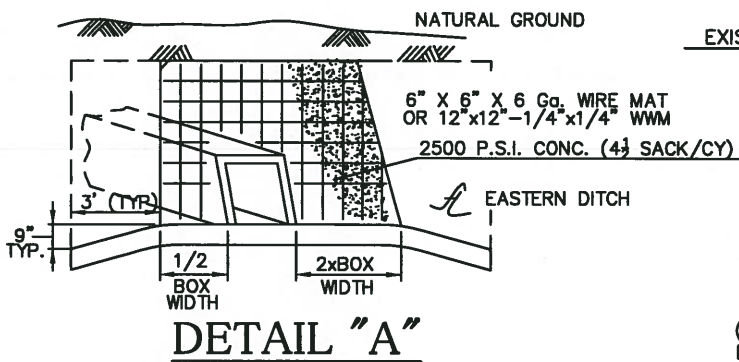
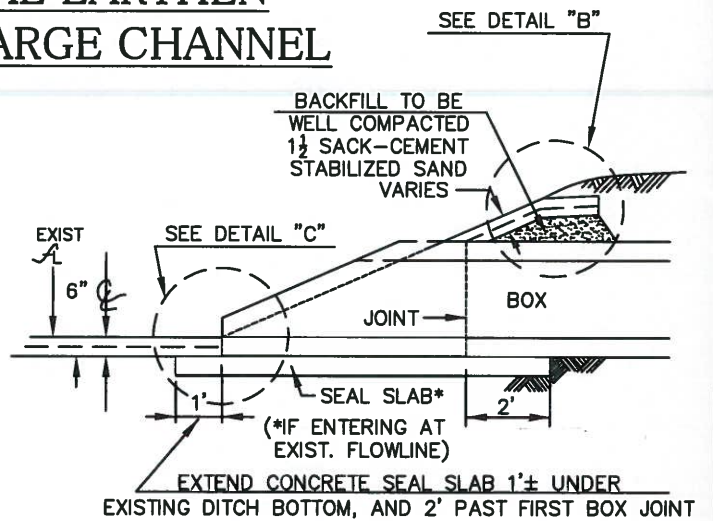
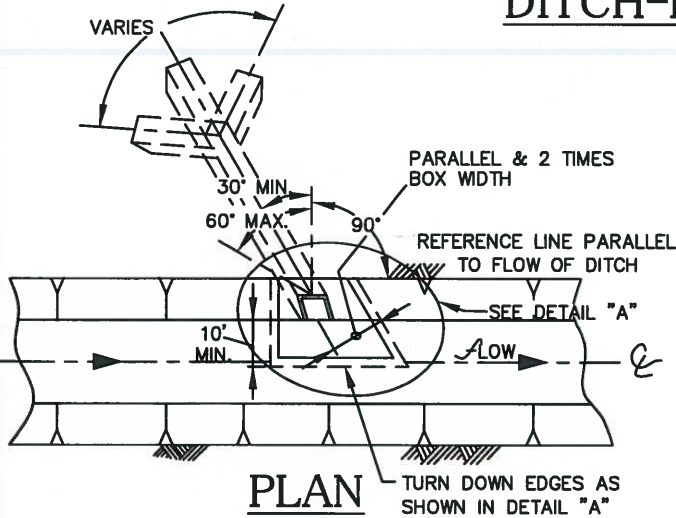

EARTHEN CHANNEL-LARGE BOX ENTRANCE STANDARD DETAIL



DGN. BY:	R.J. MITCHELL
DWN. BY:	BSL
CHECKED:	R.J. MITCHELL
FINAL CHECK:	EAL
REVISED:	10/17/11
DETAIL #:	9

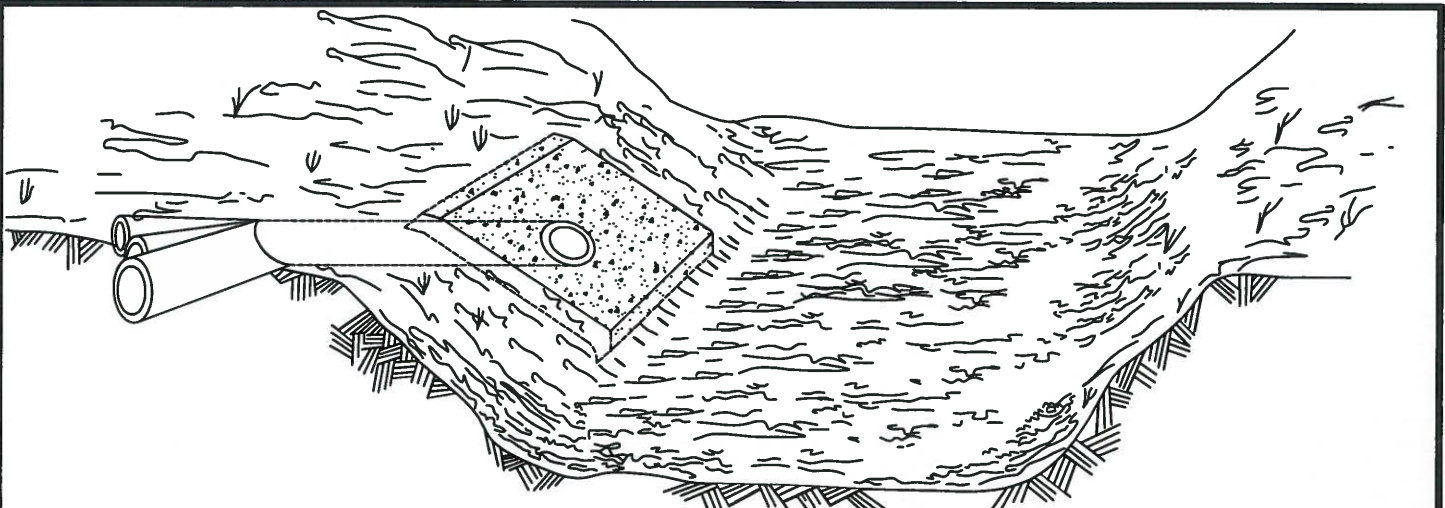

TYPICAL EARTHEN DITCH DEEP CHANNEL

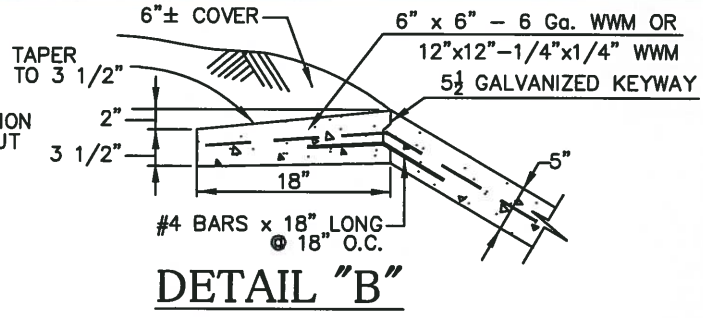
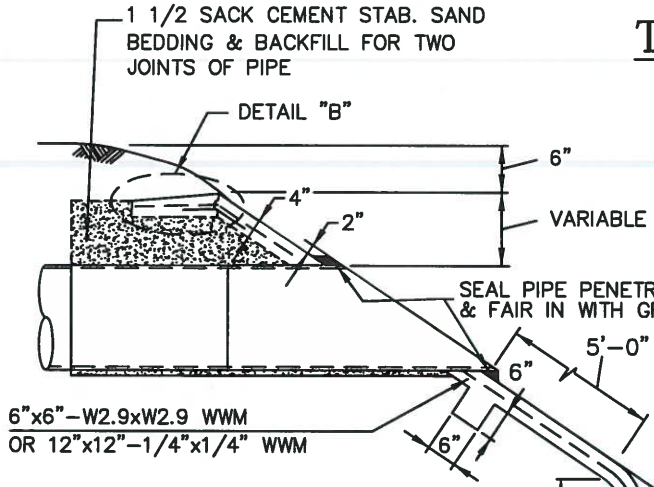

SECTION A

2500 P.S.I. CONCRETE
(4 1/2 SACK/CY)

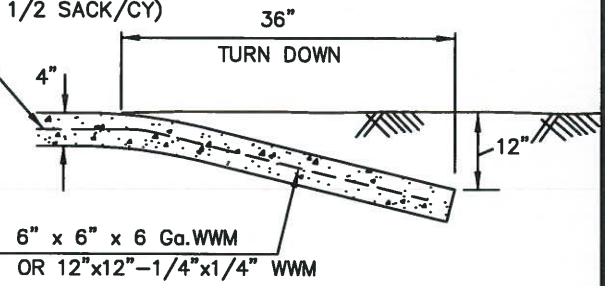

SECTION C

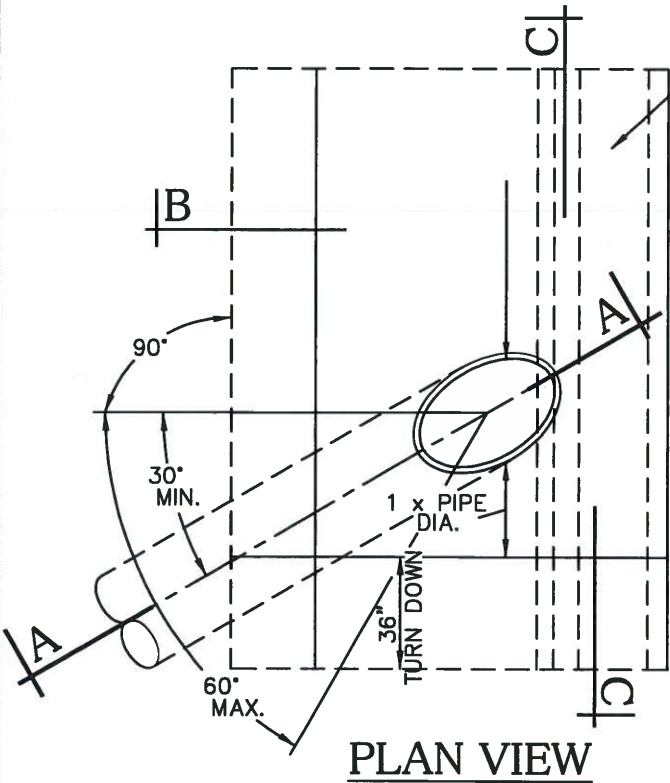

EARTHEN CHANNEL-DEEP PIPE ENTRANCE STANDARD DETAIL



DGN. BY:	R.J. MITCHELL
DWN. BY:	BSL
CHECKED:	R.J. MITCHELL
FINAL CHECK:	EAL
REVISED:	09/01/08
DETAIL #:	10

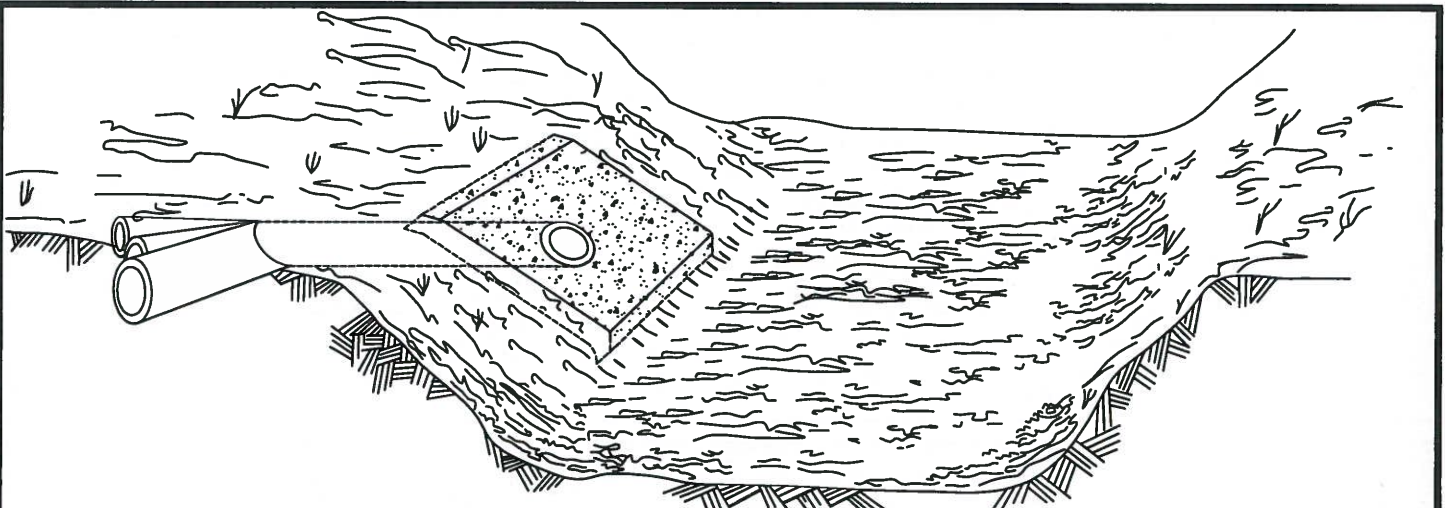

TYPICAL EARTHEN DITCH DEEP CHANNEL

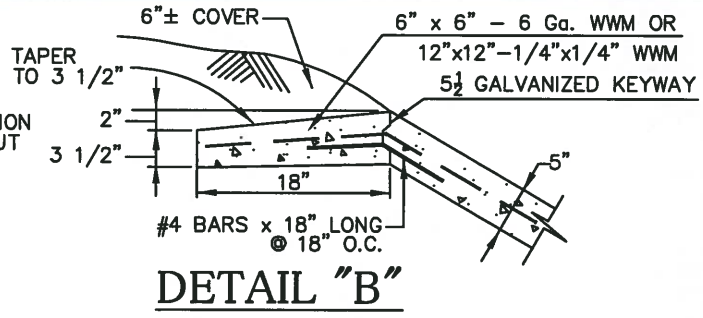
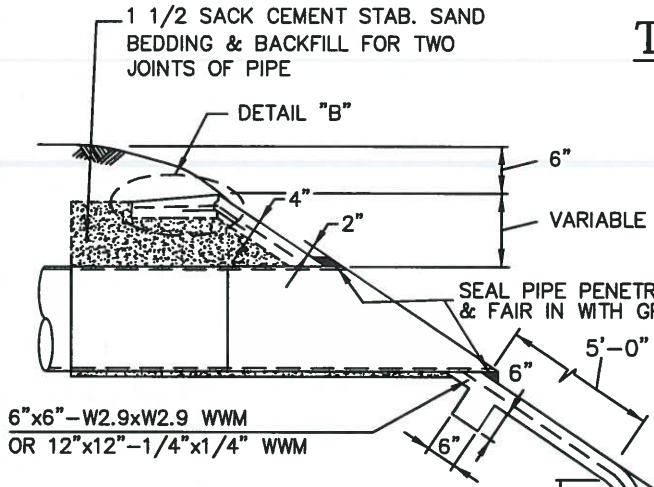

(A) SECTION

DETAIL "B"

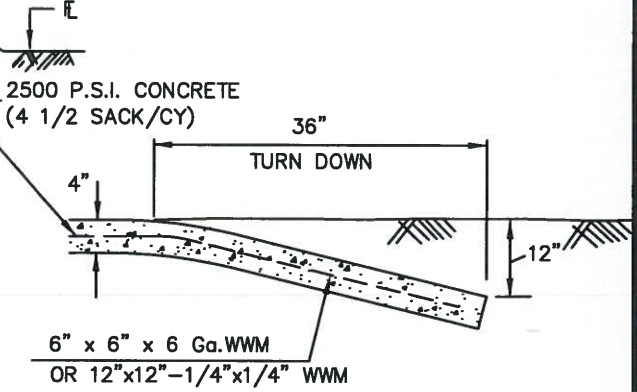
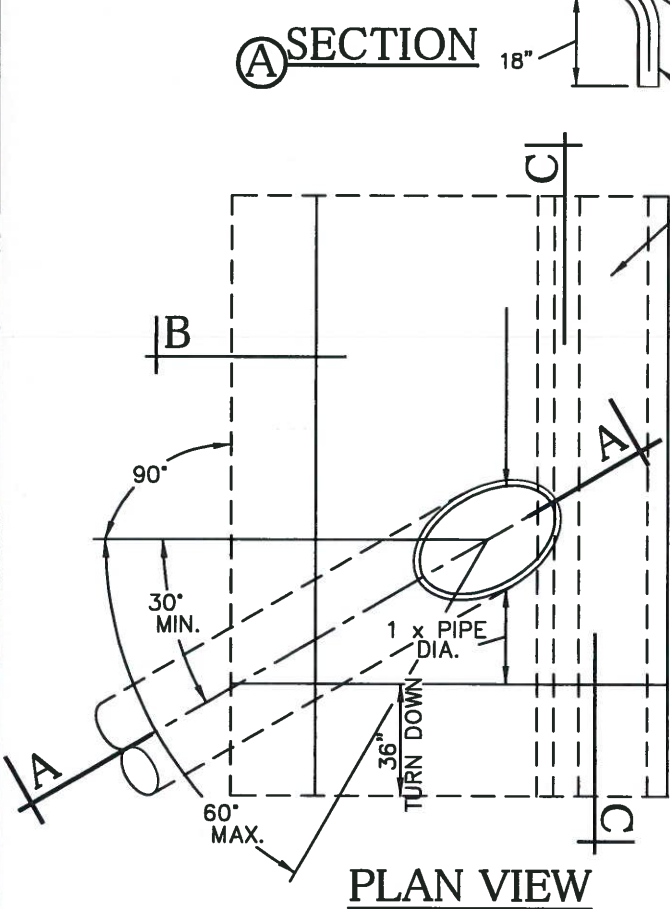

EARTHEN CHANNEL-DEEP BOX ENTRANCE STANDARD DETAIL



DGN. BY:	R.J. MITCHELL
DWN. BY:	BSL
CHECKED:	R.J. MITCHELL
FINAL CHECK:	EAL
REVISED:	09/01/08
DETAIL #:	11

TYPICAL EARTHEN DITCH

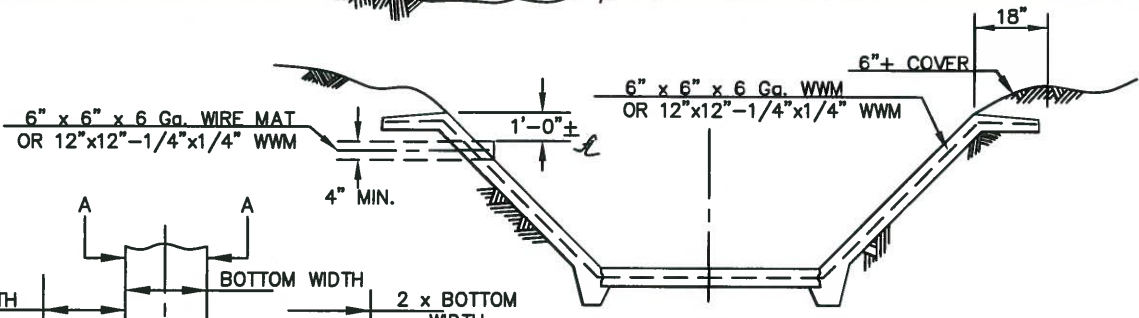
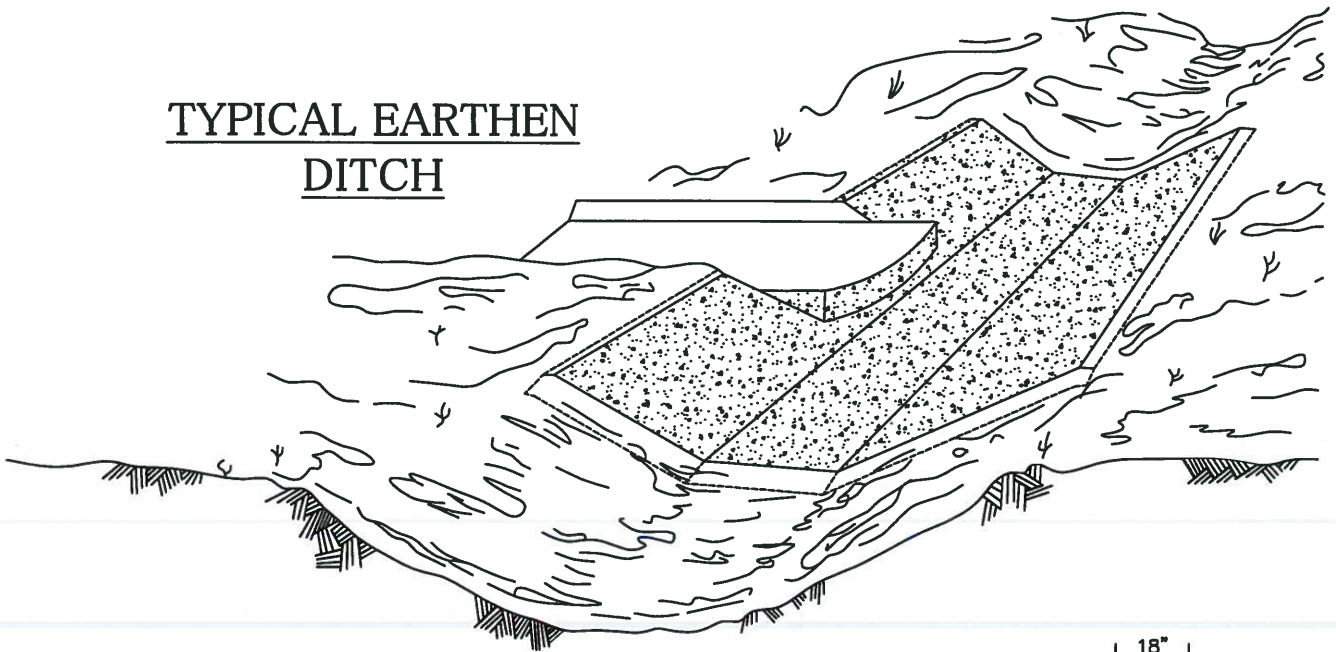

CROSS SECTION

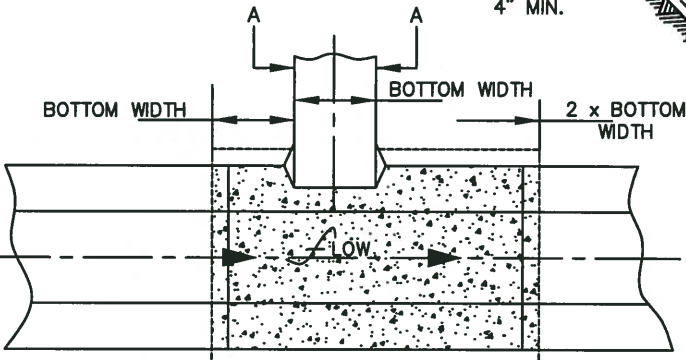

PLAN

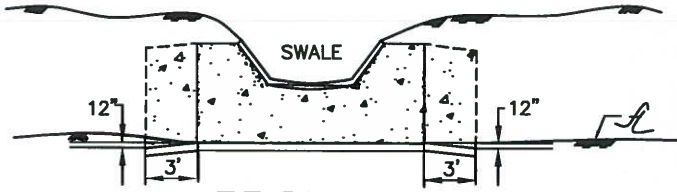

PROFILE

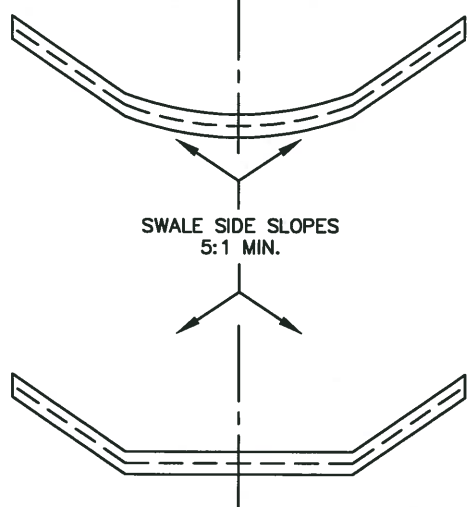

SECTION A-A

<p>EARTHEN CHANNEL SWALE DITCH ENTRANCE STANDARD DETAIL</p>	
DGN. BY:	R.J. MITCHELL
DWN. BY:	BSL
CHECKED:	R.J. MITCHELL
FINAL CHECK:	EAL
REVISED:	09/01/08
DETAIL #:	12



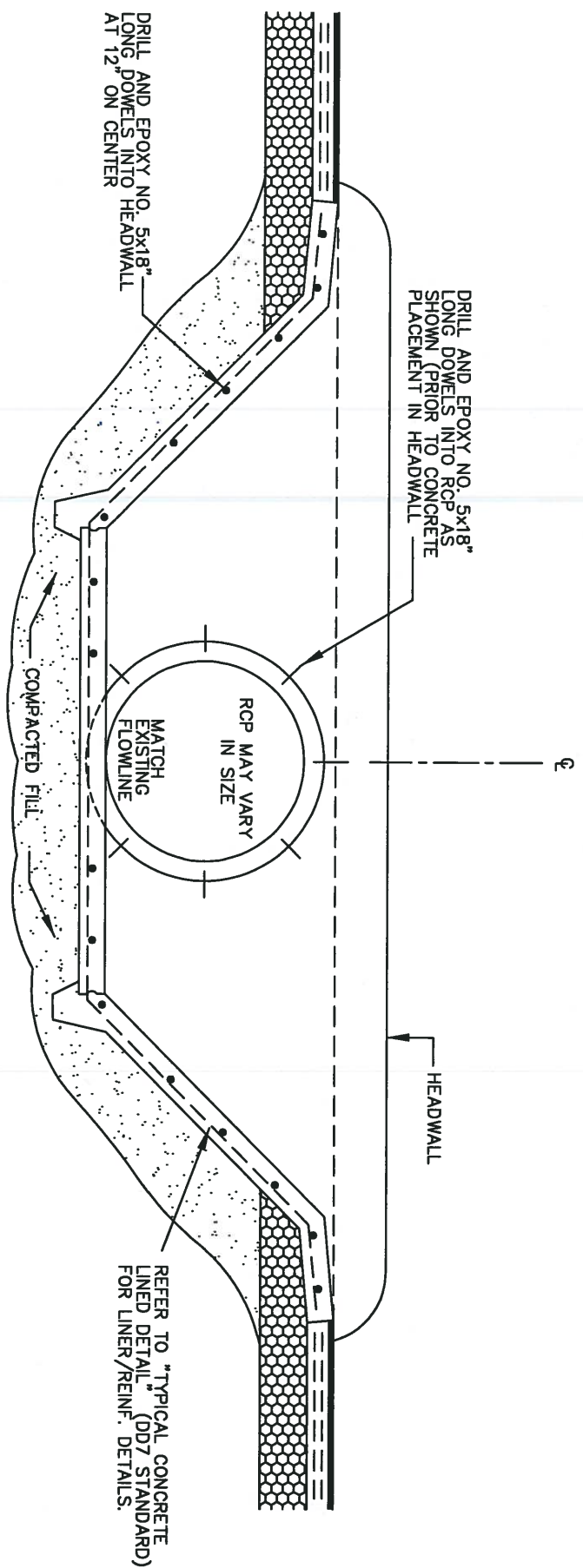

RCP PIPE/LINER TIE-IN AT HEADWALLS

(PURPOSE OF THIS DETAIL IS TO PROVIDE TIE-IN REQUIREMENTS BETWEEN PIPE/LINER AND HEADWALL AND IS NOT INTENDED AS A HEADWALL DESIGN)

- NOTES:
- 1) LINER TO BE REMOVED AND SOIL TO BE COMPACTED FOR PIPE PLACEMENT.
 - 2) PIPES TO BE PLACED AND HEADWALLS FORMED AND Poured.
 - 3) FILL TO BE PLACED AND COMPACTED PER PIPE MFG. SPECS.

HEADWALL/LINER TIE-IN (PIPE)
STANDARD DETAIL



DGN. BY: R.J. MITCHELL
 DWN. BY: BSL
 CHECKED: R.J. MITCHELL
 FINAL CHECK: EAL
 REVISED: 05/01/08
 DETAIL #: 13

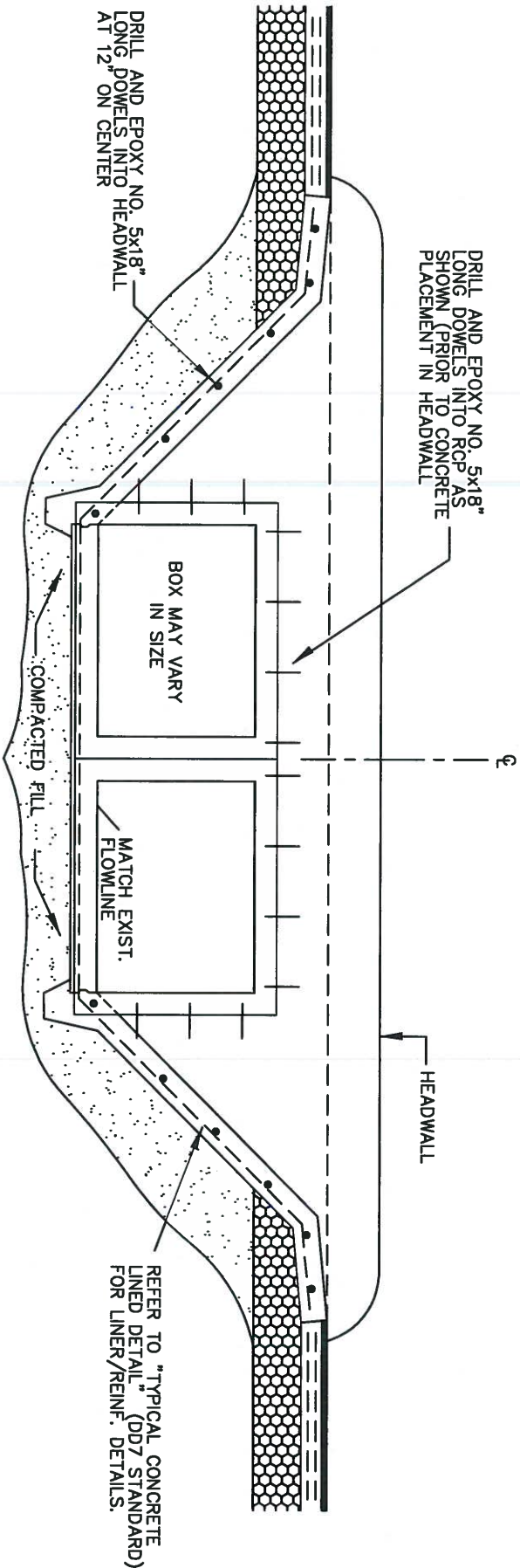

RCP PIPE/LINER TIE-IN AT HEADWALLS

(PURPOSE OF THIS DETAIL IS TO PROVIDE TIE-IN REQUIREMENTS BETWEEN PIPE/LINER AND HEADWALL AND IS NOT INTENDED AS A HEADWALL DESIGN)

- NOTES:
- 1) LINER TO BE REMOVED AND SOIL TO BE COMPACTED FOR PIPE PLACEMENT.
 - 2) PIPES TO BE PLACED AND HEADWALLS FORMED AND Poured.
 - 3) FILL TO BE PLACED AND COMPACTED PER PIPE MFG. SPECS.

HEADWALL/LINER TIE-IN (BOX)
STANDARD DETAIL

	
DGN. BY:	R.J. MITCHELL
DWN. BY:	BSL
CHECKED:	R.J. MITCHELL
FINAL CHECK:	EAL
REVISED:	05/01/08
DETAIL #:	14

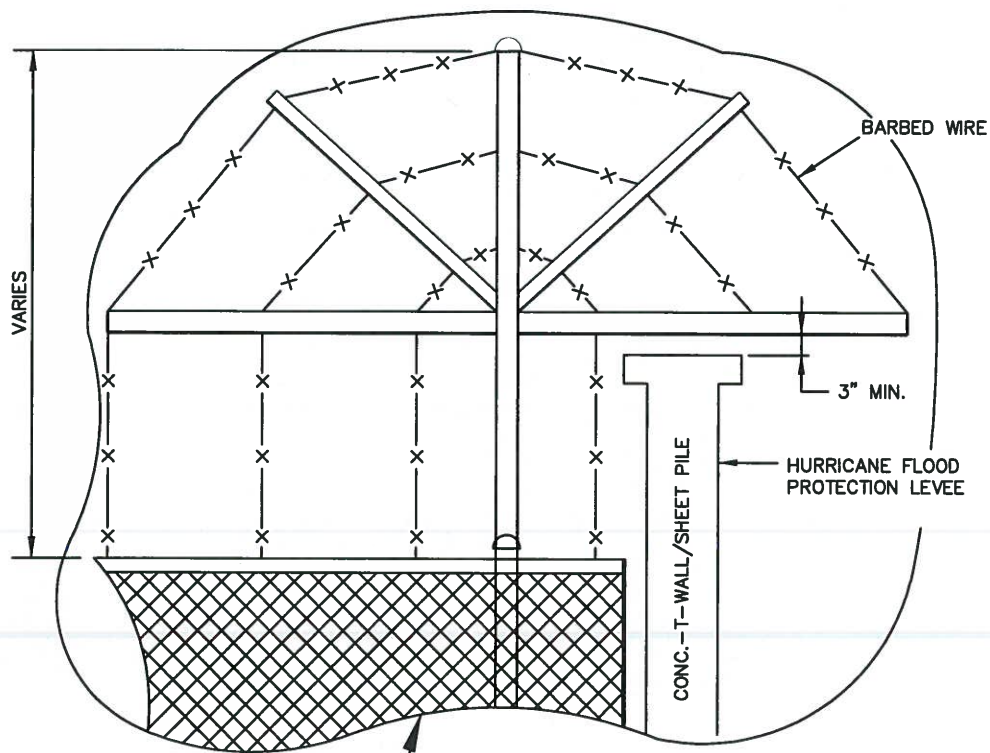

OPTIONAL

NOTE:

- 1) NO RAZOR WIRE PERMITTED
- 2) NO ATTACHMENTS PERMITTED (HFPL-WALL)
- 3) NO PENETRATIONS PERMITTED (HFPL-WALL)

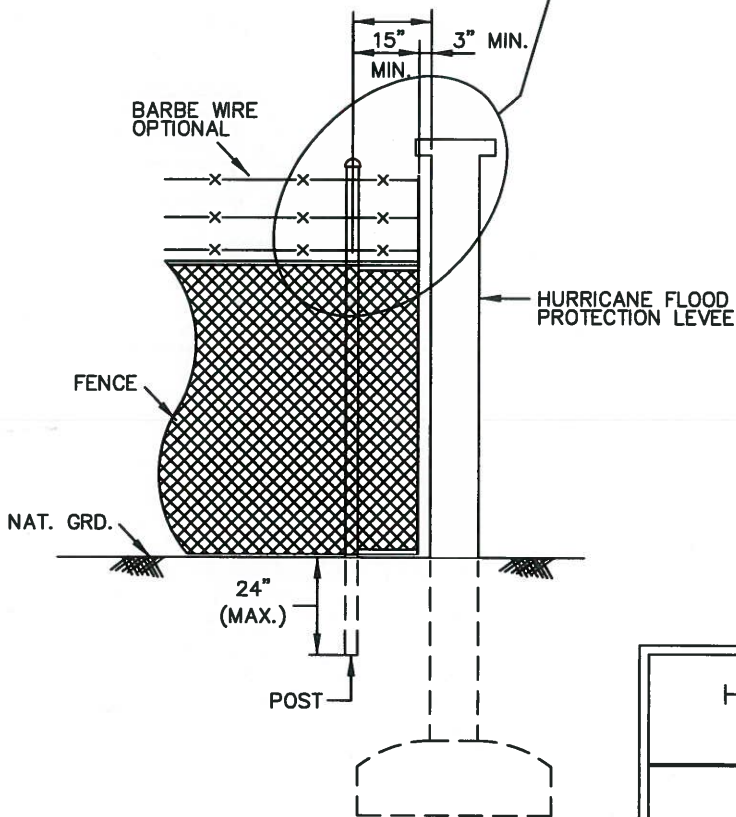

STANDARD INSTALLATION

HURRICANE FLOOD PROTECTION LEVEE
TYPICAL FENCE DETAIL



DGN. BY:	<u>R.J. MITCHELL</u>
DWN. BY:	<u>CRW</u>
CHECKED:	<u>R.J. MITCHELL</u>
FINAL CHECK:	<u>EAL</u>
REVISED:	<u>05/01/08</u>
DETAIL #:	<u>15</u>

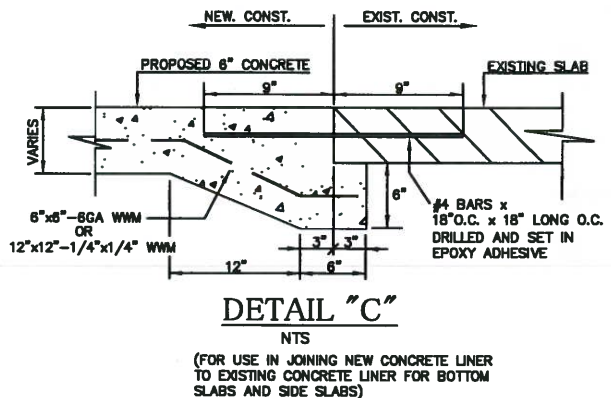
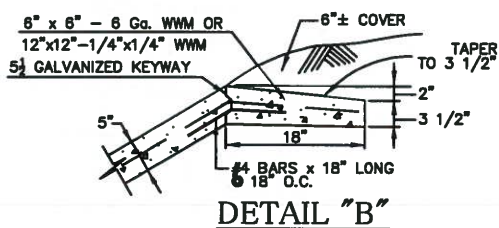
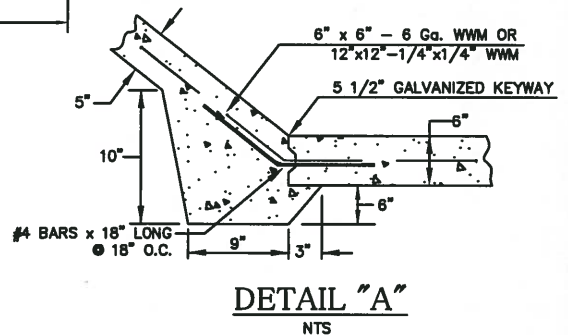
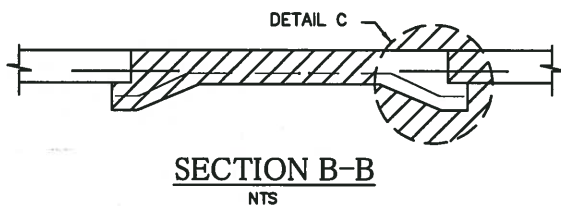
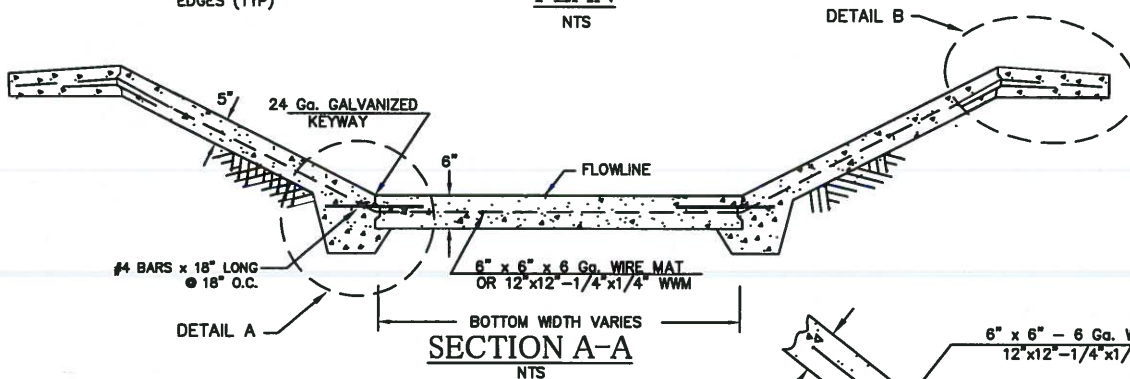
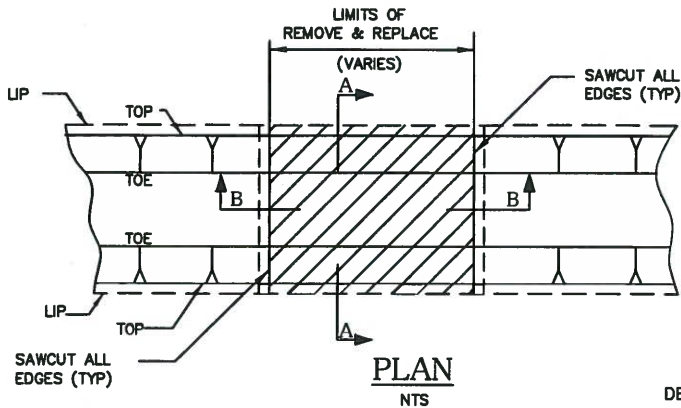

GENERAL NOTES:

- CONCRETE** - CONCRETE LINING SHALL CONTAIN A MINIMUM 4 1/2 SACK CEMENT PER CUBIC YARD OF TOTAL MIXTURE. MINIMUM COMPRESSIVE STRENGTH OF 2,500 PSI AT 28 DAYS. BOTTOM CONCRETE SHALL CONSIST OF 1" NOMINAL SIZE AGGREGATE MIX WITH BROOMED FINISH. SIDE SLOPE SHALL CONSIST OF 1/2" NOMINAL SIZE AGGREGATE MIX. AN OVERSANDS MIX MAY BE USED ON SIDE SLOPE WALLS WITH BROOMED FINISH. FORMS MAY BE REMOVED WHEN CONCRETE HAS AGED 24 HRS. MINIMUM.
- KEYWAYS** - SHALL BE FORMED USING 5 1/2" GALVANIZED KEYWAYS, STAGGERED 10' FROM BOTTOM KEYWAY.
- WIRE MAT** - SHALL CONSIST OF 6"x6"-6"GA. OR 12"x12"-1/4"x1/4" WWM WITH ALL WIRE/REBAR TO BE TIED.
- DOWELS** - ALL DOWELS ARE TO BE NO. 4 (1/2"DIA.) x 18" LONG @ 18" O.C.
- FINAL DRESS** - UPON PROJECT COMPLETION, ENTIRE AREA IS TO BE DRESSED DOWN AND SEEDS. PROJECT SITE SHALL BE SEEDS WITH BERMUDA AT A RATE OF 3 LBS. PER 1,000 SQ. FT. OR 130 LBS. PER ACRE.

**CONCRETE LINED CHANNEL
REMOVE & REPLACE-PATCH**



DGN. BY: R.J. MITCHELL
 DWN. BY: BSL
 CHECKED: R.J. MITCHELL
 FINAL CHECK: EAL
 REVISED: 05/01/08
 DETAIL #: 16

NOTE:
 HORIZONTAL & VERTICAL SIDESLOPE
 BEAMS SHALL BE USED WHEN SLOPE
 LENGTH "L" IS GREATER THAN 10' OR
 WHEN LINER IS STEEPER THAN
 1.25 HORZ:1 VERT SLOPE

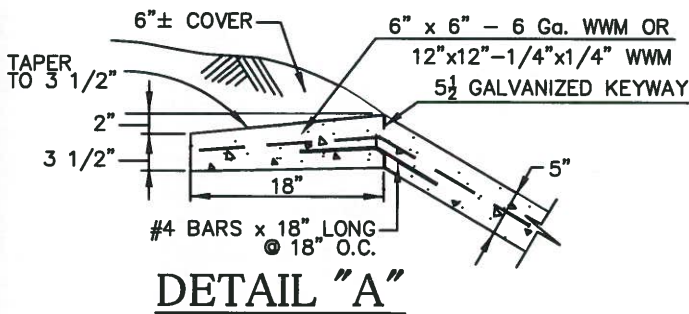
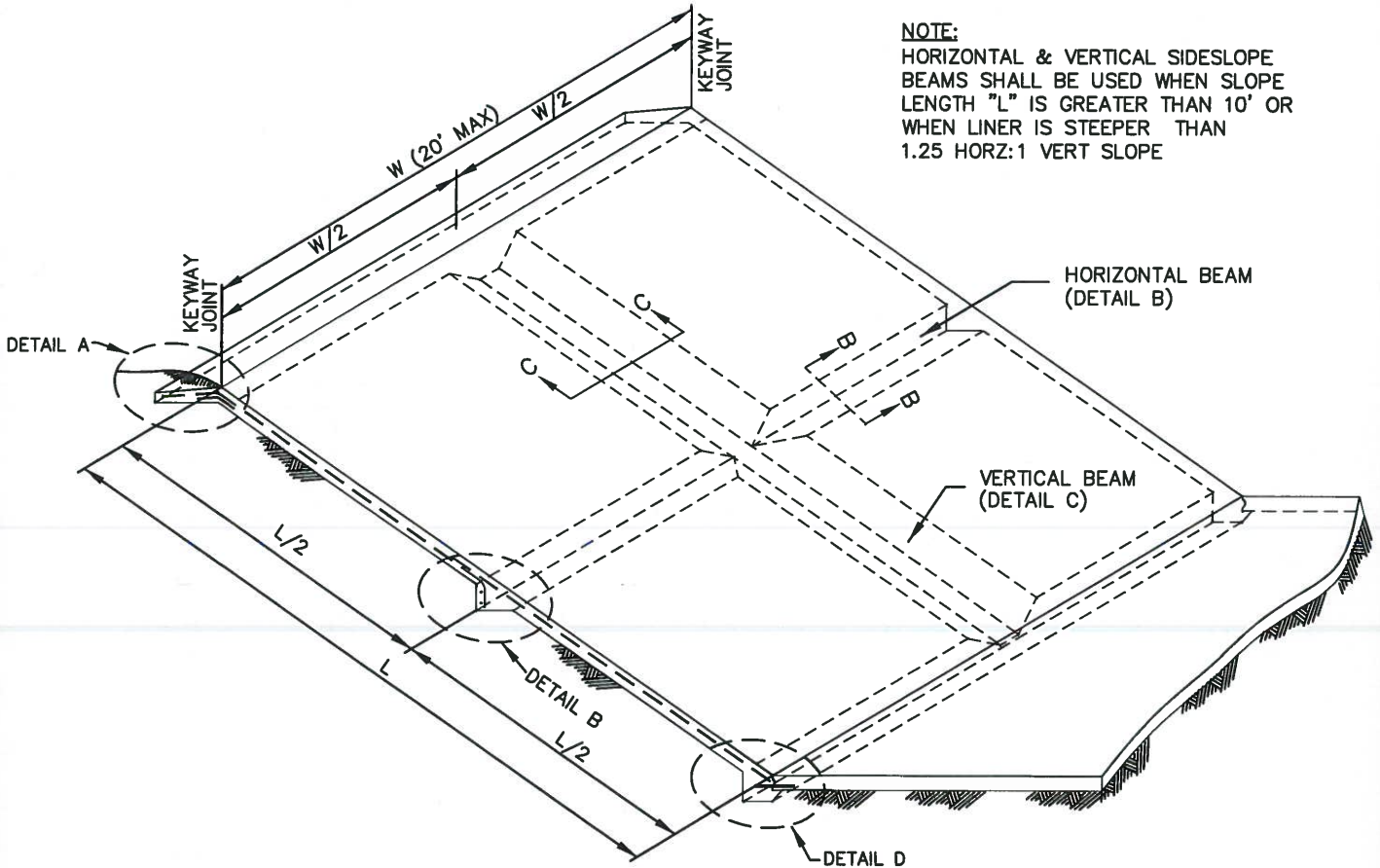

DETAIL "A"

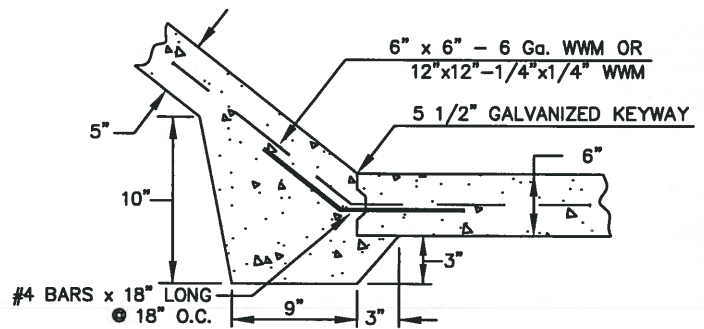

DETAIL "D"

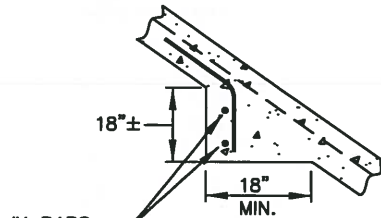

DETAIL "B"
 (HORIZONTAL BEAM)

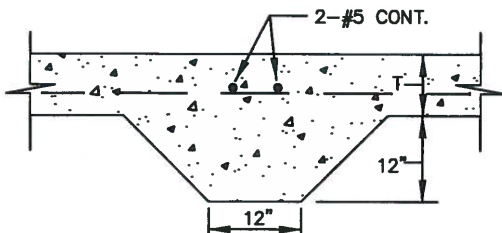

DETAIL "C"
 (VERTICAL BEAM)

**CONCRETE LINED CHANNEL
 SIDEWALL OVER 10' IN LENGTH**



DGN. BY: R.J. MITCHELL
 DWN. BY: CRW
 CHECKED: R.J. MITCHELL
 FINAL CHECK: EAL
 REVISED: 05/17/13
 DETAIL #: 17

CHANNEL BOTTOM

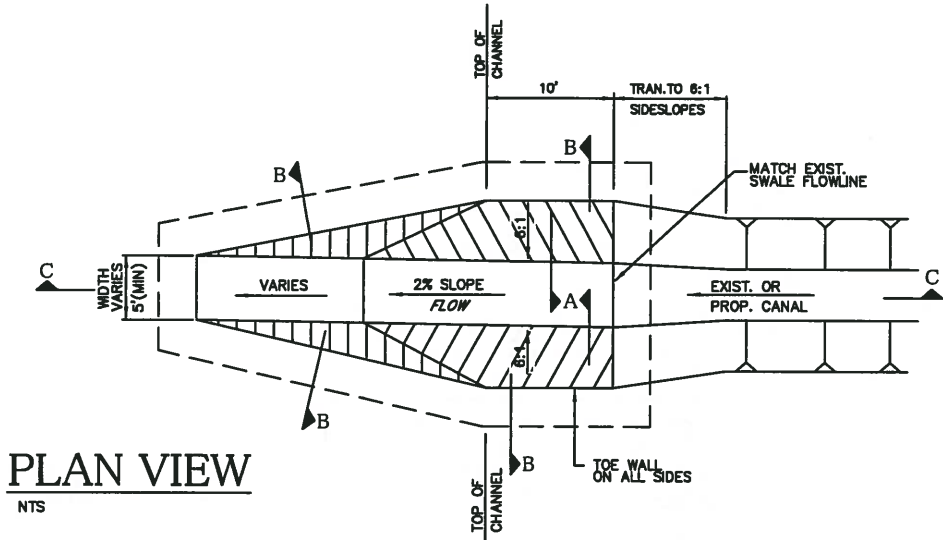

PLAN VIEW

NTS

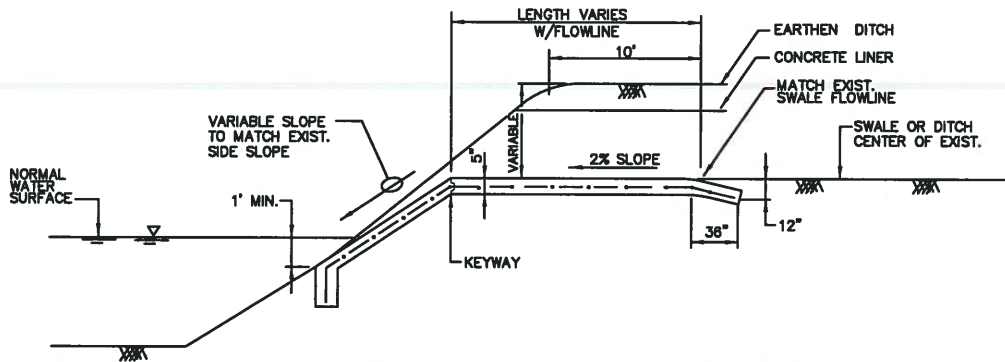

© TYPICAL SPILLWAY SECTION

NTS

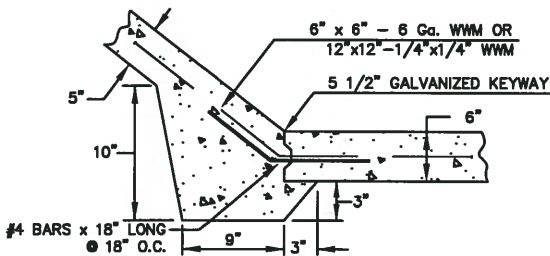

(A) SECTION-TYPICAL

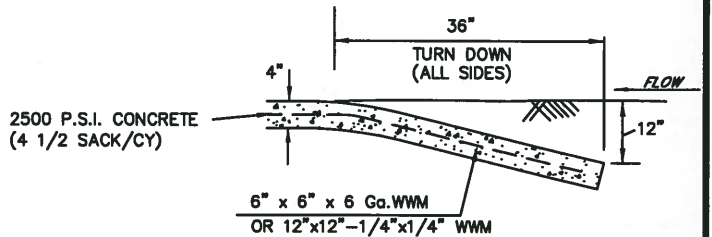

(B) SECTION-TYPICAL

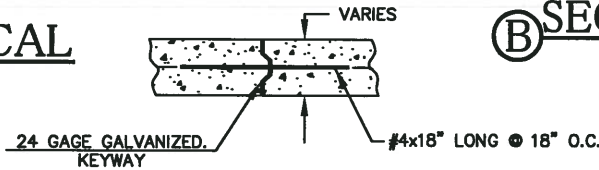

TYPICAL KEYWAY

GENERAL NOTES:

- CONCRETE** - CONCRETE LINING SHALL CONTAIN A MINIMUM 4 1/2 SACK CEMENT PER CUBIC YARD OF TOTAL MIXTURE. MINIMUM COMPRESSIVE STRENGTH OF 2,500 PSI AT 28 DAYS. BOTTOM CONCRETE SHALL CONSIST OF 1" NOMINAL SIZE AGGREGATE MIX WITH BROOMED FINISH. SIDE SLOPE SHALL CONSIST OF 1/2" NOMINAL SIZE AGGREGATE MIX. AN OVERSANDED MIX MAY BE USED ON SIDE SLOPE WALLS WITH BROOMED FINISH. FORMS MAY BE REMOVED WHEN CONCRETE HAS AGED 24 HRS. MINIMUM.
- KEYWAYS** - SHALL BE FORMED USING 5 1/2" GALVANIZED KEYWAYS AND SIDE SLOPE SHALL BE FORMED USING 3 1/2" GALV. KEYWAYS, STAGGERED 10' FROM BOTTOM KEYWAY.
- WIRE MAT** - SHALL CONSIST OF 6"x6"-6"GA. OR 12"x12"-1/4"x1/4" WWM WITH ALL WIRE/REBAR TO BE TIED.
- DOWELS** - ALL DOWELS ARE TO BE NO. 4 (1/2"DIA.) x 18" LONG @ 18"O.C.
- FINAL DRESS** - UPON PROJECT COMPLETION, ENTIRE AREA IS TO BE DRESSED DOWN AND SEEDED. PROJECT SITE SHALL BE SEEDDED WITH BERMUDA AT A RATE OF 3 LBS. PER 1,000 SQ. FT. OR 130 LBS. PER ACRE.

**CONCRETE LINED CHANNEL
TYPICAL SPILLWAY SECTION**



DGN. BY: R.J. MITCHELL
 DWN. BY: CRW
 CHECKED: R.J. MITCHELL
 FINAL CHECK: EAL
 REVISED: 07/15/10
 DETAIL #: 18

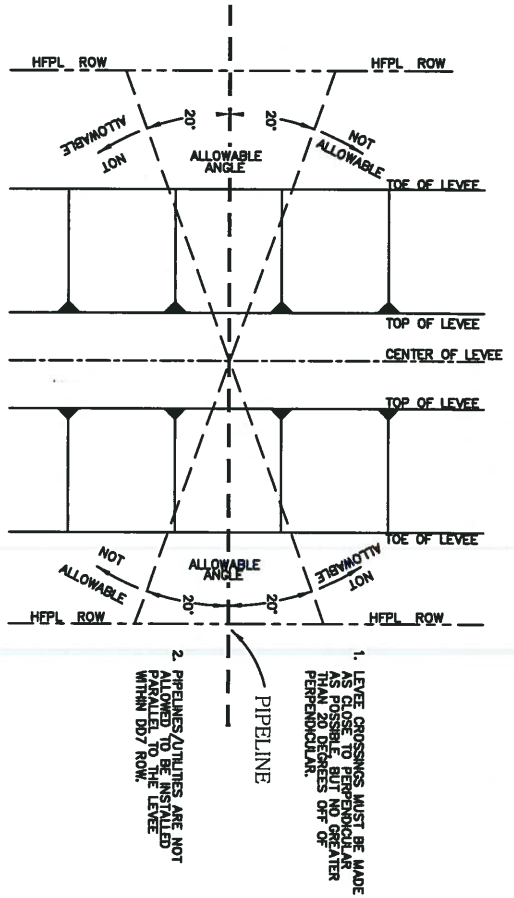

PLAN VIEW

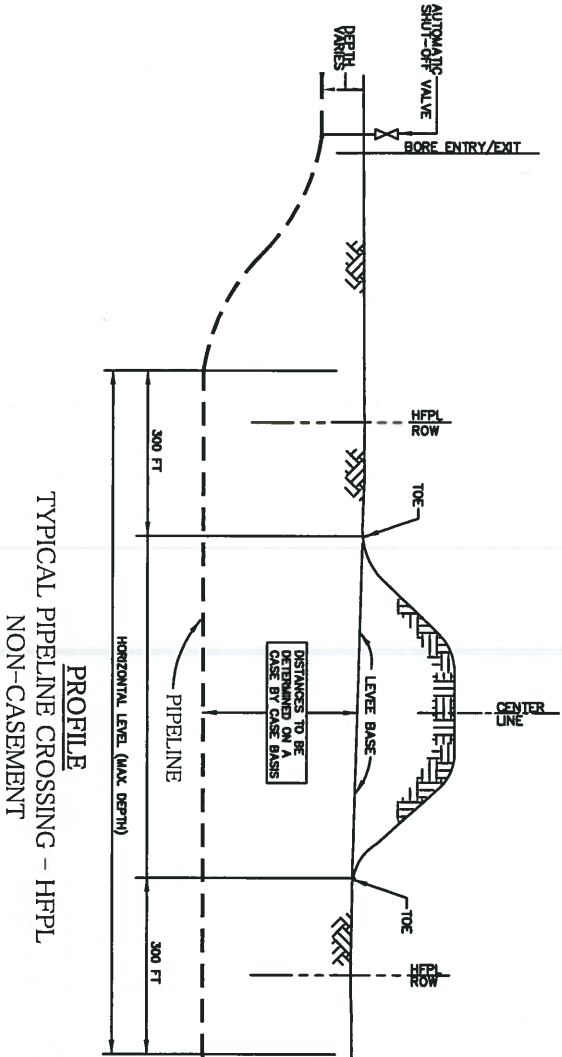

PROFILE
TYPICAL PIPELINE CROSSING - HFPL
NON-CASEMENT

SPECIFICATIONS FOR CROSSINGS OF THE HURRICANE FLOOD PROTECTION LEVEE

1. "NOT DIRECTIONAL DRILLING WILL BE ALLOWED UNDERNEATH FLOOD WALLS.
2. SHUT OFF VALVES: ALL PIPELINE CROSSINGS WILL REQUIRE AUTOMATIC SHUT-OFF VALVES AT THE POINTS OF CROSSING ON EACH SIDE OF THE RIGHT-OF-WAY OR A REASONABLE DISTANCE OUTSIDE OF RIGHT-OF-WAY.
3. DIRECTIONAL BORE METHOD: THE DIRECTIONAL BORE METHOD OF INSTALLATION OF THE PIPELINE OR OTHER PROPOSED FACILITY SHALL BE BORED A MINIMUM OF 10 FEET BELOW TOE ELEVATION (LEVEE BASE) OF LEVEE SECTION TO BE CROSSED. ENTRANCE AND DISCHARGE SITES OF SAND BORING SHALL BE THE MINIMUM OF 10 FEET TO BE DETERMINED ON A CASE BY CASE BASIS) FEET FROM TOE OF LEVEE. THE DIRECTIONAL DRILLING PROCESS SHALL INCLUDE A MAGNETIC OR WIRE LINE GUIDANCE SYSTEM. THE RESULTS OF THE GUIDANCE SYSTEM SHALL BE DELIVERED TO THE DISTRICT FOR RECORD.
4. CALCULATIONS ARE REQUIRED DEMONSTRATING THAT THE DOWNHOLE MUD PRESSURE DURING THE DRILLING OPERATION RESULTS IN A MINIMUM FACTOR OF SAFETY EQUAL TO 2.0 AGAINST HYDRAULIC FRACTURE OF THE LEVEE FOUNDATION WITHIN 300-FT OF THE LEVEE TOE. THE METHOD FOR CALCULATING THE ALLOWABLE MUD PRESSURE WILL BE THE DELTA EQUATION AS PRESENTED IN GP-AR-GL-98-1 (STAHELL, ET AL, 1998).
5. PROPOSED PIPELINE ENTRY OR EXIST POINT, SHOULD BE SET BACK SUFFICIENTLY SUCH THAT THE PIPELINE REACHES ITS HORIZONTAL LEVEL (MAXIMUM DEPTH) AT LEAST 300-FT FROM THE LEVEE TOE(S) (SEE PROFILE).

DIRECTIONAL/DIRECT PIPE BORE (HDD)
HURRICANE FLOOD PROTECTION LEVEE (HFPL)



DGN. BY: R.J. MITCHELL
 DWN. BY: ORW
 CHECKED: R.J. MITCHELL
 FINAL CHECK: EAL
 REVISED: 10/11/13
 DETAIL #: 19

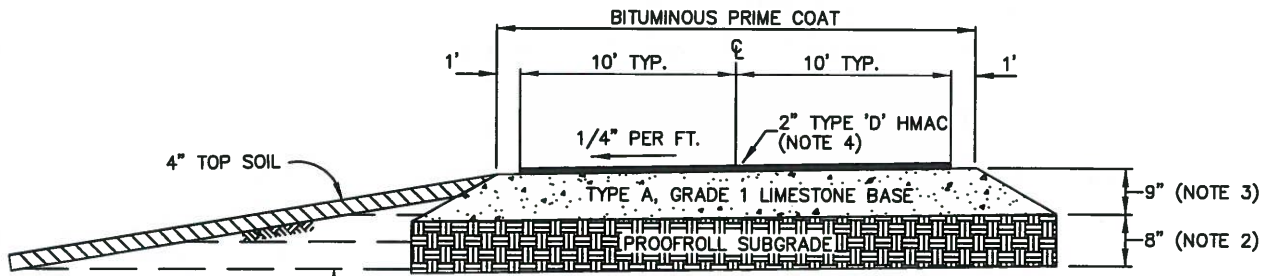

TYPICAL ROAD SECTION-LEVEE CROWN
N.T.S.

REFER TO LEVEE REPAIR
DETAIL ABOVE FOR REPAIR
TO THIS AREA

PAVING NOTES:

1. REMOVE EXISTING ASPHALT CONCRETE PAVEMENT AND BASE IN ACCORDANCE WITH TxDOT 2004 STANDARD SPECIFICATIONS, ITEM 105. AREAS DESIGNATED FOR NEW PAVEMENT SHALL BE STRIPPED OF ALL VEGETATION, LOOSE TOPSOIL AND OTHER DELETERIOUS MATERIALS.
2. THE EXISTING ROADBED SUBGRADE SHALL THEN BE PROOF-ROLLED WITH AT LEAST A 15-TON ROLLER, LOADED DUMP TRUCK, OR EQUIVALENT, TO DETECT WEAK AREAS. SAID WEAK AREAS SHOULD BE REMOVED AND REPLACED WITH 8" OF FILL MATERIAL CONSISTING OF CLEAN FAT CLAY (CH) OR LEAN CLAY (CL) SOILS WITH A MINIMUM LIQUID LIMIT OF 40 AND A MINIMUM PLASTICITY INDEX OF 20.
3. SPREAD AND SHAPE CRUSHED LIMESTONE OVER THE SUBGRADE IN ACCORDANCE WITH TxDOT SPECIFICATIONS, ITEM 247, TYPE A, GRADE 1. THE BASE SHOULD BE COMPACTED IN MAXIMUM 9-INCH COMPACTED LIFTS TO A MINIMUM OF 95% MAXIMUM DENSITY AS DETERMINED BY ASTM D1557 AT -2% TO +3% OF OPTIMUM MOISTURE CONTENT.
4. THE COMPACTED LIMESTONE BASE SHALL BE PRIMED WITH MC-1 CUT BACK ASPHALT AT A RATE OF 0.20 GALLONS PER SQUARE YARD. OVER THE PRIMED LIMESTONE BASE, PLACE 2-INCH THICK COMPACTED, PLANT MIXED, HOT LAID, ASPHALT CONCRETE, TYPE D, IN ACCORDANCE WITH TxDOT SPECIFICATIONS, ITEM 340. COMPACT USING ORDINARY COMPACTION CONTROL.
5. CONSTRUCTION SURVEILLANCE BY AN INDEPENDENT CONSTRUCTION MATERIALS TESTING COMPANY IS RECOMMENDED TO DOCUMENT THAT ALL REQUIREMENTS OF THIS TECHNICAL SPECIFICATION FOR REPAIRS TO THE HURRICANE FLOOD PROTECTION LEVEE HAVE ROAD HAVE BEEN MET.
6. ALL ASPHALT REPAIRS SHALL BE SAW CUT. SAW CUTS SHALL BE MADE 3 FEET WIDER THAN THE REPAIR AREA (PARALLEL TO LEVEE CENTERLINE) AND EXTEND 5 FEET BEYOND THE REPAIR AREA (PERPENDICULAR TO THE LEVEE CENTERLINE) AS DETERMINED BY DISTRICT.

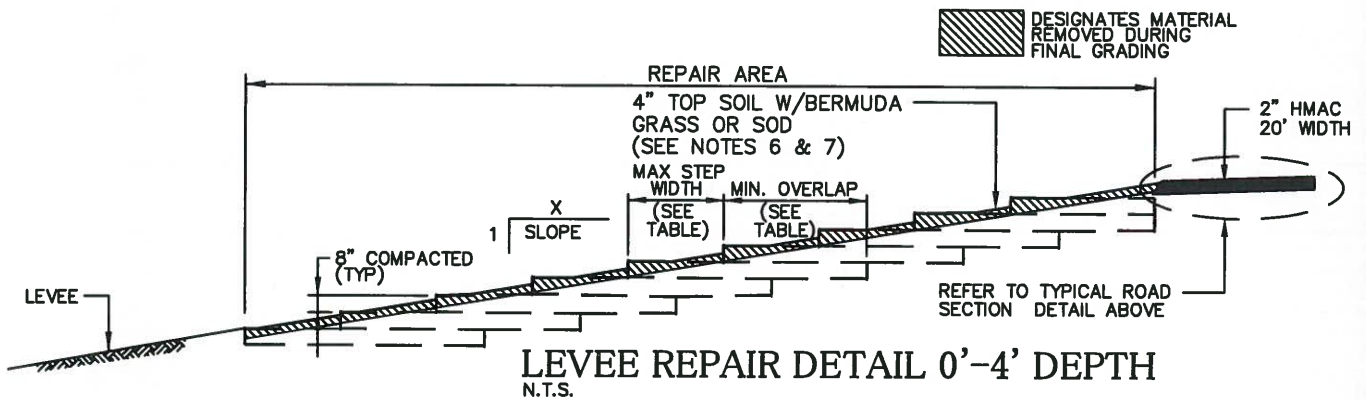

LEVEE REPAIR DETAIL 0'-4' DEPTH
N.T.S.

GENERAL NOTES FOR REPAIR OF DAMAGED LEVEE:

1. DD7 SHALL BE CONTACTED PRIOR TO ANY WORK BEING PERFORMED WITHIN THE IMPACT AREAS. ALL WORK SHALL BE APPROVED BY DD7 PRIOR TO PERFORMANCE OF WORK.
2. REMOVE TOPSOIL FROM DAMAGED AREA AND STOCKPILE FOR REUSE.
3. SCARIFY SUBGRADE BEFORE PLACEMENT OF FILL TO ENSURE A GOOD BOND WITH EXISTING SUBGRADE.
4. ALL FILL SHALL BE PLACED IN HORIZONTAL LIFTS TO A MAXIMUM 8-INCH COMPACTED THICKNESS.
5. IMPORTED CLAY SOIL SHALL HAVE A PLASTICITY INDEX GREATER THAN 25 AND BE COMPACTED TO 95% OF THE STANDARD PROCTOR MAXIMUM DRY DENSITY (ASTM D698)
6. UPON FINAL GRADING, A 4-INCH LAYER OF COMPACTED TOPSOIL SHALL BE INSTALLED.
7. FINAL SURFACE SHALL BE FERTILIZED AND HYDRO-MULCHED WITH BERMUDA GRASS OR NURSERY GROWN, MACHINE CUT, SOD. CONTRACTOR SHALL PROVIDE SUFFICIENT WATERING UNTIL BERMUDA GRASS OR SOD HAS TAKEN ROOT.

LEVEE SLOPE (H:V)	MAX. THICKNESS OF COMPACTED LIFT (INCHES)	WIDTH OF OF LIFT (INCHES)	MAX. STEP WIDTH (INCHES)	MIN. STEP OVERLAP (INCHES)
3:1	8"	60"	24"	36"
4:1	8"	80"	32"	48"
5:1	8"	100"	40"	60"
6:1	8"	120"	48"	72"

MINOR LEVEE/ROAD REPAIR



DGN. BY: EAL/JRS
 DWN. BY: CRW
 CHECKED: R.J. MITCHELL
 FINAL CHECK: EAL
 REVISED: 08/13/12
 DETAIL #: 20

LEEVE SLOPE (H:V)	MAX. THICKNESS OF COMPACTED LIFT (INCHES)	WIDTH OF OF LIFT (INCHES)	MAX. STEP WIDTH (INCHES)	MIN. STEP OVERLAP (INCHES)
3:1	8"	60"	24"	36"
4:1	8"	80"	32"	48"
5:1	8"	100"	40"	60"
6:1	8"	120"	48"	72"

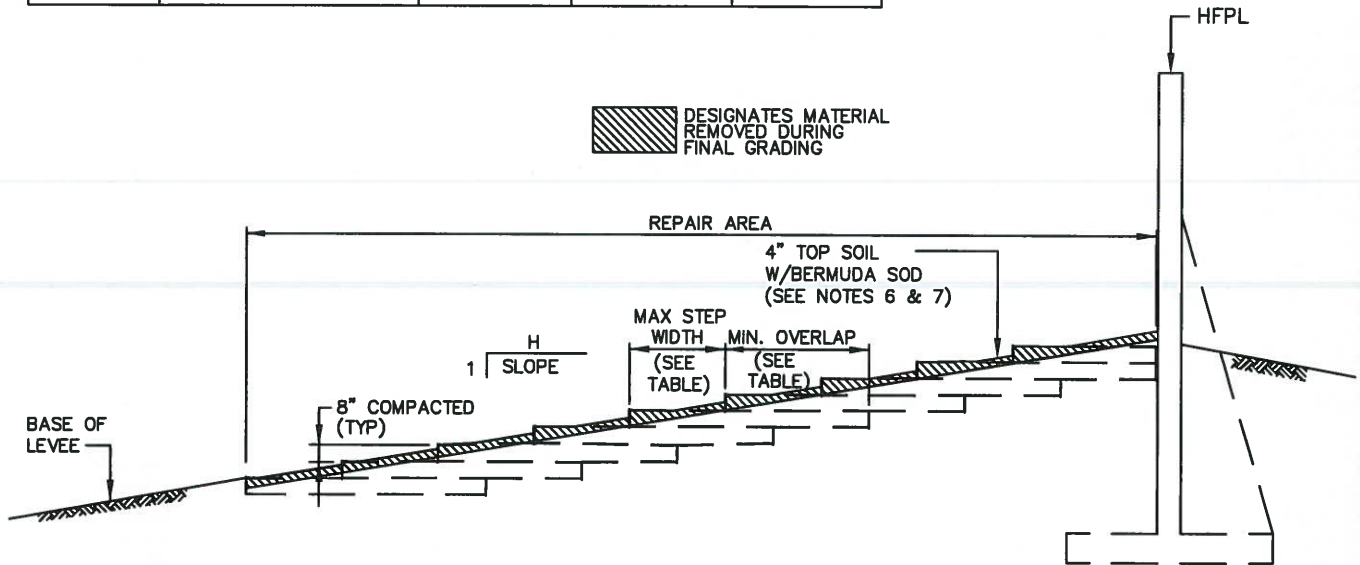

LEEVE REPAIR DETAIL 0'-4' DEPTH
N.T.S.

GENERAL NOTES FOR REPAIR OF DAMAGED LEVEE:

1. DD7 SHALL BE CONTACTED PRIOR TO ANY WORK BEING PERFORMED WITHIN THE IMPACT AREAS. ALL WORK SHALL BE APPROVED BY DD7 PRIOR TO PERFORMANCE OF WORK.
2. REMOVE TOPSOIL FROM DAMAGED AREA AND STOCKPILE FOR REUSE.
3. SCARIFY SUBGRADE BEFORE PLACEMENT OF FILL TO ENSURE A GOOD BOND WITH EXISTING SUBGRADE.
4. ALL FILL SHALL BE PLACED IN HORIZONTAL LIFTS TO A MAXIMUM 8-INCH COMPACTED THICKNESS.
5. IMPORTED CLAY SOIL SHALL HAVE A PLASTICITY INDEX GREATER THAN 25 AND BE COMPACTED TO 95% OF THE STANDARD PROCTOR MAXIMUM DRY DENSITY (ASTM D698)
6. UPON FINAL GRADING, A 4-INCH LAYER OF COMPACTED TOPSOIL SHALL BE INSTALLED.
7. FINAL SURFACE SHALL BE FERTILIZED AND HYDRO-MULCHED WITH BERMUDA GRASS. CONTRACTOR SHALL PROVIDE SUFFICIENT WATERINGS UNTIL BERMUDA GRASS HAS TAKEN ROOT.

**MINOR LEVEE REPAIR
WALL SECTION-SLOPE**



DGN. BY: EAL/JRS
DWN. BY: CRW
CHECKED: R.J. MITCHELL
FINAL CHECK: EAL
REVISED: 12/13/11
DETAIL #: 21

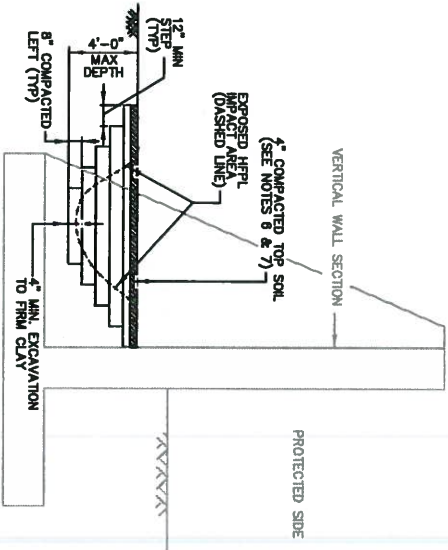
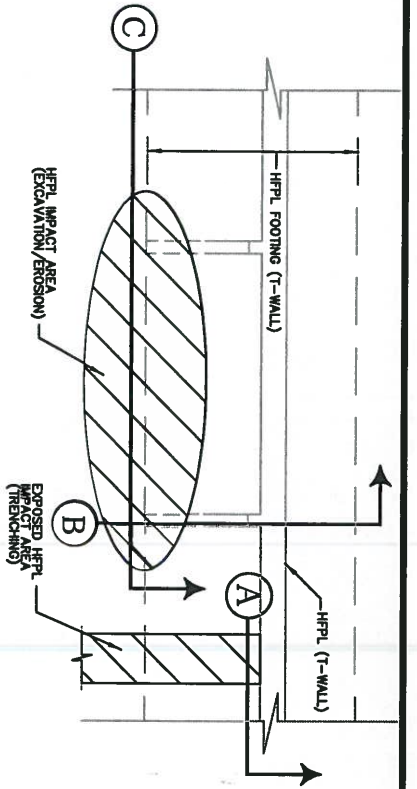

B SECTION
N.T.S.

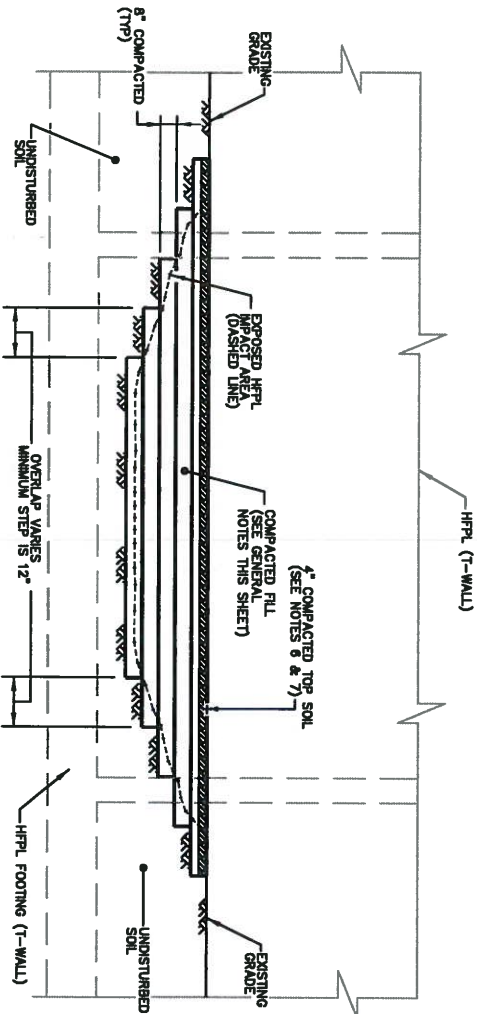

C SECTION
N.T.S.

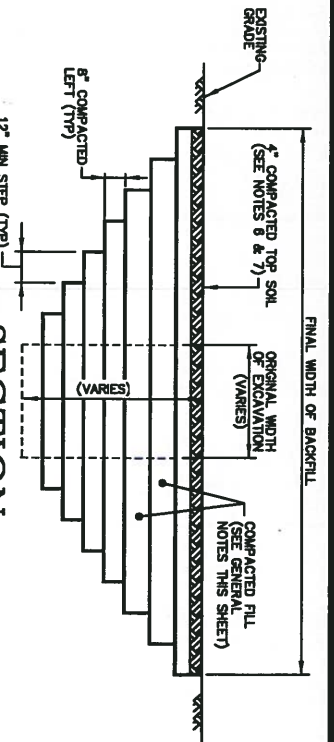

- GENERAL NOTES FOR REPAIR OF DAMAGED LEVEE:
- DDT SHALL BE CONTACTED PRIOR TO ANY WORK BEING PERFORMED WITHIN THE IMPACT AREAS. ALL WORK SHALL BE APPROVED BY DDT PRIOR TO PERFORMANCE OF WORK.
 - REMOVE TOPSOIL FROM DAMAGED AREA AND STOCKPILE FOR REUSE.
 - SCARIFY SUBGRADE BEFORE PLACEMENT OF FILL TO ENSURE A GOOD BOND WITH EXISTING SUBGRADE.
 - ALL FILL SHALL BE PLACED IN HORIZONTAL LIFTS TO A MAXIMUM 8-INCH COMPACTED THICKNESS.
 - IMPORTED CLAY SOIL SHALL HAVE A PLASTICITY INDEX GREATER THAN 25 AND BE COMPACTED TO 95% OF THE STANDARD PROCTOR MAXIMUM DRY DENSITY (ASTM D698).
 - UPON FINAL GRADING, A 4-INCH LAYER OF COMPACTED TOPSOIL SHALL BE INSTALLED.
 - FINAL SURFACE SHALL BE FERTILIZED AND HYDRO-MULCHED WITH BERMUDA GRASS. CONTRACTOR SHALL PROVIDE SUFFICIENT WATERINGS UNTIL BERMUDA GRASS HAS TAKEN ROOT.

MINDR HRP L REPAIR-WALL SECTION
WALL SECTION-LEVEL



DGN. BY: R.J. MITCHELL
 DWN. BY: CRW
 CHECKED: R.J. MITCHELL
 FINAL CHECK: EAL
 REVISED: 12/13/11
 DETAIL #: 22

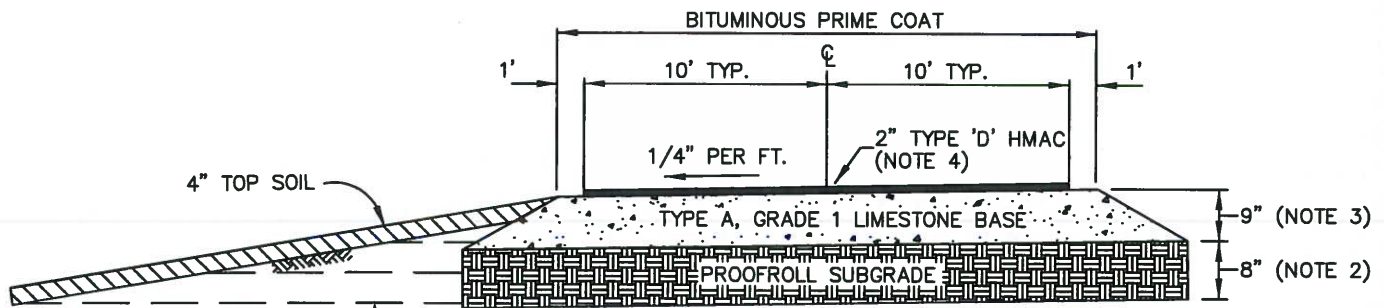

REFER TO MINOR LEVEE REPAIR
DETAIL (DETAIL 501.20) FOR REPAIR
TO THIS AREA

TYPICAL ROAD SECTION-LEVEE CROWN

N.T.S.

PAVING NOTES:

1. REMOVE EXISTING ASPHALT CONCRETE PAVEMENT AND BASE IN ACCORDANCE WITH TxDOT 2004 STANDARD SPECIFICATIONS, ITEM 105, AREAS DESIGNATED FOR NEW PAVEMENT SHALL BE STRIPPED OF ALL VEGETATION, LOOSE TOP SOIL AND OTHER DELETERIOUS MATERIALS.
2. THE EXISTING ROADBED SUBGRADE SHALL THEN BE PROOF-ROLLED WITH AT LEAST A 15-TON ROLLER, LOADED DUMP TRUCK, OR EQUIVALENT, TO DETECT WEAK AREAS. SAID WEAK AREAS SHOULD BE REMOVED AND REPLACED WITH 8" OF FILL MATERIAL CONSISTING OF CLEAN FAT CLAY (CH) OR LEAN CLAY (CL) SOILS WITH A MINIMUM LIQUID LIMIT OF 40 AND A MINIMUM SPLASTICITY INDEX OF 20.
3. SPREAD AND SHAPE CRUSHED LIMESTONE OVER THE SUBGRADE IN ACCORDANCE WITH TxDOT SPECIFICATIONS, ITEM 247, TYPE A, GRADE 1. THE BASE SHOULD BE COMPACTED IN MAXIMUM 9-INCH COMPACTED LIFTS TO A MINIMUM OF 95% MAXIMUM DENSITY AS DETERMINED BY ASTM D1557 AT -2% TO +3% OF OPTIMUM MOISTURE CONTENT.
4. THE COMPACTED LIMESTONE BASE SHALL BE PRIMED WITH MC-1 CUT BACK ASPHALT AT A RATE OF 0.20 GALLONS PER SQUARE YARD. OVER THE PRIMED LIMESTONE BASE, PLACE 2-INCH THICK COMPACTED, PLANT MIXED, HOT LAID, ASPHALT CONCRETE, TYPE D, IN ACCORDANCE WITH TxDOT SPECIFICATIONS, ITEM 340. COMPACT USING ORDINARY COMPACTION CONTROL.
5. CONSTRUCTION SURVEILLANCE BY AN INDEPENDENT CONSTRUCTION MATERIALS TESTING COMPANY IS RECOMMENDED TO DOCUMENT THAT ALL REQUIREMENTS OF THIS TECHNICAL SPECIFICATION FOR REPAIRS TO THE HURRICANE FLOOD PROTECTION LEVEE HAVE ROAD HAVE BEEN MET.
6. ALL ASPHALT REPAIRS SHALL BE SAW CUT. SAW CUTS SHALL BE MADE 3 FEET WIDER THAN THE REPAIR AREA (PARALLEL TO LEVEE CENTERLINE) AND EXTEND 5 FEET BEYOND THE REPAIR AREA (PERPENDICULAR TO THE LEVEE CENTERLINE) AS DETERMINED BY DISTRICT.

TYPICAL ROAD SECTION-LEVEE CROWN



DGN. BY:	<u>EAL/JRS</u>
DWN. BY:	<u>CRW</u>
CHECKED:	<u>R.J. MITCHELL</u>
FINAL CHECK:	<u>EAL</u>
REVISED:	<u>08/13/12</u>
DETAIL #:	<u>23</u>

SPECIFICATIONS FOR CROSSINGS OF EARTHEN AND CONCRETE LINED CHANNELS:

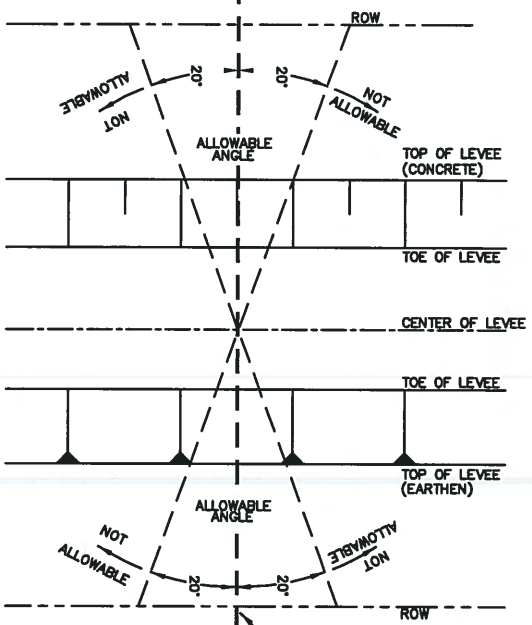

1. CHANNEL CROSSINGS MUST BE MADE AS CLOSE TO PERPENDICULAR AS POSSIBLE BUT NO GREATER THAN 20 DEGREES OFF OF PERPENDICULAR.
2. PIPELINES/UTILITIES ARE NOT ALLOWED TO BE INSTALLED WITHIN DD7 ROW.

PLAN VIEW

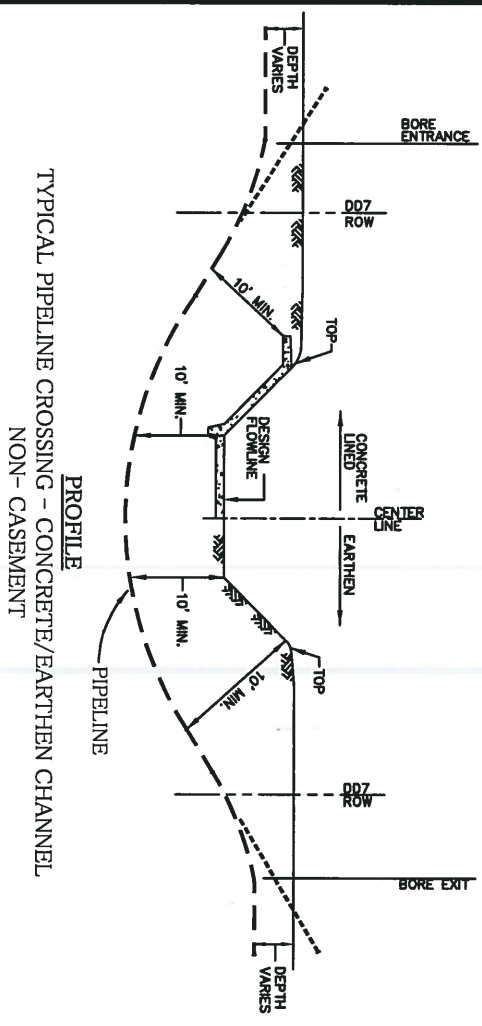

PROFILE
TYPICAL PIPELINE CROSSING - CONCRETE/EARTHEN CHANNEL
NON-CASEMENT

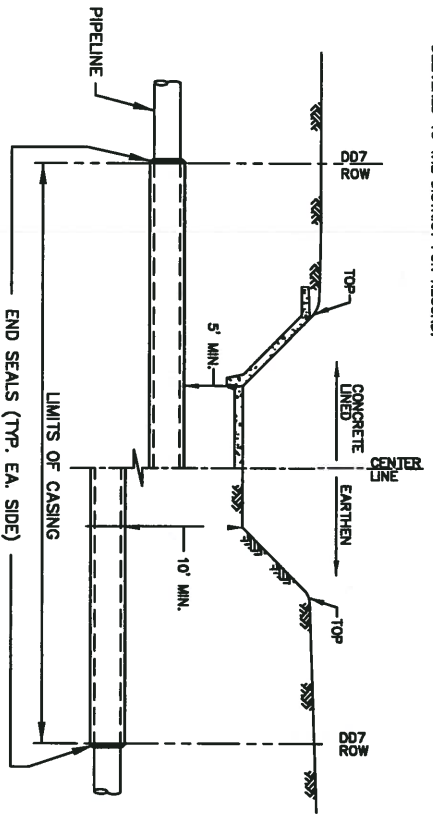

PROFILE
TYPICAL PIPELINE CROSSING - CONCRETE/EARTHEN CHANNEL
CASEMENT

1. HORIZONTAL BORE METHOD. THE HORIZONTAL BORE METHOD OF INSTALLATION OF THE PIPELINE OR OTHER PROPOSED FACILITY MAY BE BORED OR JACKED UNDER THE CHANNEL FROM ROW TO ROW AND PLACED IN A STEEL OR OTHER APPROVED CASING OF LARGER DIAMETER THAN THE UTILITY OR PIPELINE. SUCH CASING SHALL EXTEND THE FULL WIDTH OF THE ROW AND SHALL BE SEALED AROUND THE PIPE IN AN ACCEPTABLE MANNER ON EACH END. WATER-JETTING WILL NOT BE PERMITTED. SUITABLE PITS OR TRENCHES SHALL BE EXCAVATED FOR CONDUCTING THE BORING OPERATIONS AND FOR PLACING THE PIPE. WORK SHALL BE SHEATHED SECURELY AND BRACED IN A MANNER SATISFACTORY TO PREVENT EARTH CAVING AND IN ACCORDANCE WITH A TRENCH EXCAVATION AND SHORING SAFETY PLAN. THE LOCATION OF THE PIPE SHALL MEET THE APPROVAL OF THE DISTRICT. THE HOLES ARE TO BE BORED MECHANICALLY. THE BORING SHALL BE DONE USING A PILOT HOLE. BY THIS METHOD AN APPROXIMATE 2 INCH PILOT HOLE SHALL BE BORED THE ENTIRE LENGTH OF THE CROSSING AND SHALL BE CHECKED FOR LINE AND GRADE ON THE OPPOSITE END OF THE BORE FROM THE WORK PIT. THIS PILOT HOLE SHALL SERVE AS THE CENTERLINE OF THE LARGER DIAMETER HOLE TO BE BORED. EXCAVATED MATERIAL WILL BE PLACED NEAR THE TOP OF THE WORKING PIT AND DISPOSED OF AS REQUIRED. THE USE OF WATER OR OTHER FLUIDS IN CONNECTION WITH THE BORING OPERATION WILL BE PERMITTED ONLY TO LUBRICATE CUTTINGS; JETTING WILL NOT BE PERMITTED. IF UNCONSOLIDATED SOIL FORMATIONS ARE ENCOUNTERED, A GEL-FORMING COLLOIDAL DRILLING FLUID CONSISTING OF AT LEAST 10 PERCENT OF HIGH GRADE CAREFULLY PROCESSED BENTONITE MAY BE USED TO CONSOLIDATE CUTTINGS OF THE BIT, SEAL THE WALLS OF THE HOLE, AND FURNISH LUBRICATION FOR SUBSEQUENT REMOVAL OF CUTTING AND INSTALLATION OF THE PIPE IMMEDIATELY THEREAFTER.
2. DIRECTIONAL BORE METHOD. THE DIRECTIONAL BORE METHOD OF INSTALLATION OF THE PIPELINE OR OTHER PROPOSED FACILITY SHALL BE BORED A MINIMUM OF TEN FEET (10'-) FEET BELOW DESIGN FLOWLINE OF CHANNEL TO BE CROSSED, ENTRANCE AND DISCHARGE SITES OF SAID BORING SHALL BE LOCATED OUTSIDE OF THE DISTRICT'S RIGHT OF WAY. THE DIRECTIONAL DRILLING PROCESS SHALL INCLUDE A MARKING OR WIRE LINE GUIDANCE SYSTEM. THE RESULTS OF THE GUIDANCE SYSTEM SHALL BE DELIVERED TO THE DISTRICT FOR RECORD.

**HORIZONTAL/DIRECTIONAL BORE
CONCRETE/EARTHEN CHANNEL**



DGN. BY: R.J. MITCHELL
 DWN. BY: CRW
 CHECKED: R.J. MITCHELL
 FINAL CHECK: EAL
 REVISED: 09/13/12
 DETAIL #: 24

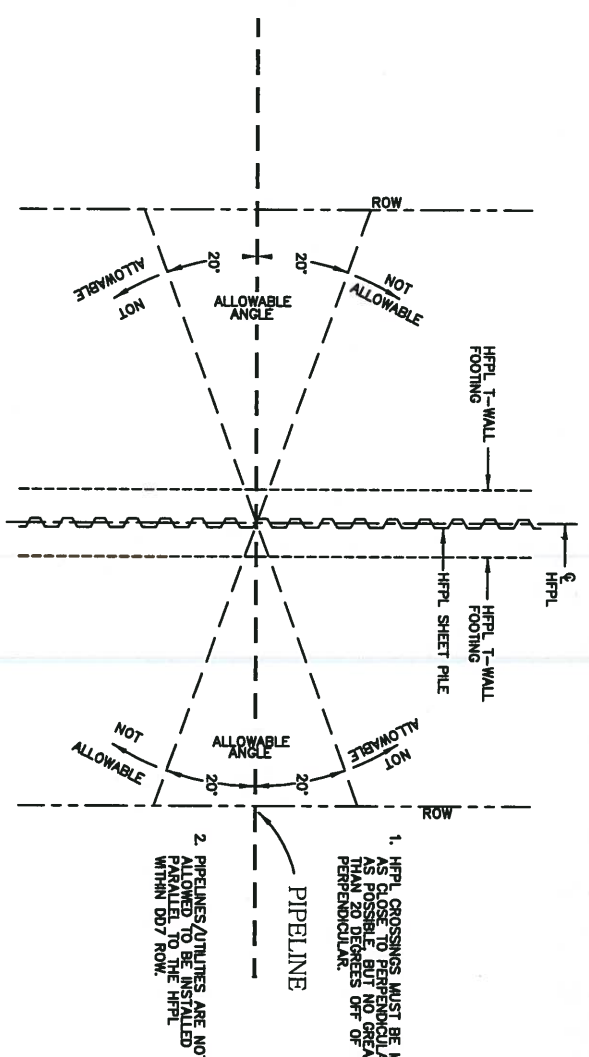

PLAN VIEW

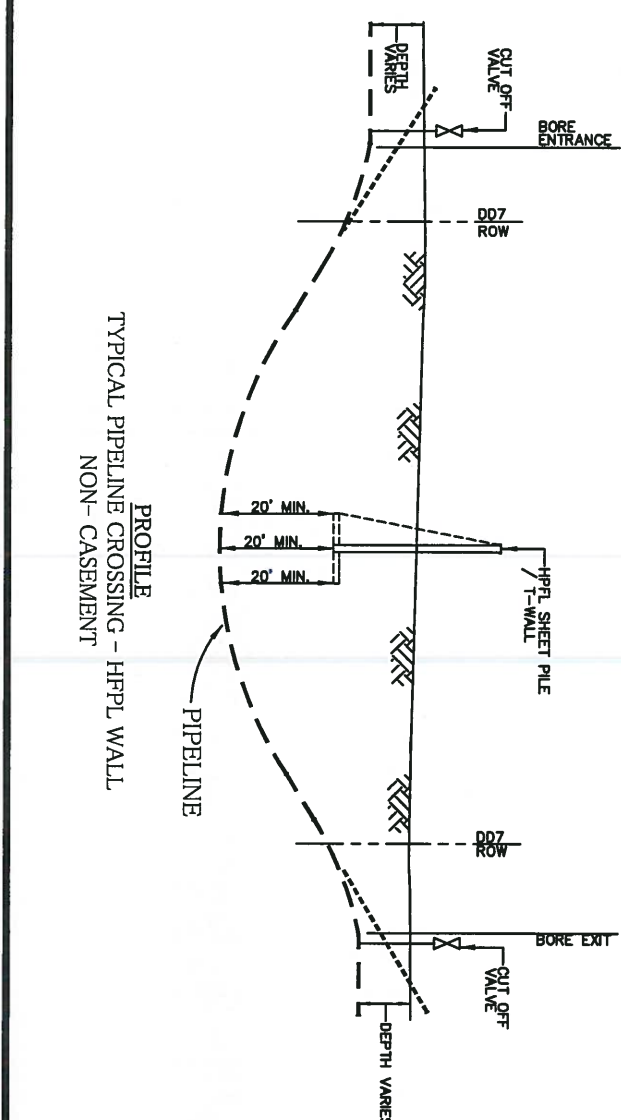

TYPICAL PIPELINE CROSSING - HFPPL WALL
NON-CASEMENT

- SPECIFICATIONS FOR CROSSINGS OF EARTHEN AND CONCRETE LINED CHANNELS:**
1. SHUT OFF VALVES. ALL PIPELINE CROSSINGS WILL REQUIRE SHUT-OFF VALVES AT THE POINTS OF CROSSING ON EACH SIDE OF THE RIGHT-OF-WAY OR A REASONABLE DISTANCE OUTSIDE OF RIGHT-OF-WAY.
 2. HORIZONTAL BORE METHOD. THE HORIZONTAL BORE METHOD OF INSTALLATION OF THE PIPELINE OR OTHER PROPOSED FACILITY MAY BE BORED OR JACKED UNDER THE HFPPL WALL FROM ROW TO ROW AND PLACED IN A STEEL OR OTHER APPROVED CASING OF LARGER DIAMETER THAN THE UTILITY OR PIPELINE. SUCH CASING SHALL EXTEND THE FULL WIDTH OF THE ROW AND SHALL BE SEALED AROUND THE PIPE IN AN ACCEPTABLE MANNER ON EACH END. *WATER-LEAKING WILL NOT BE PERMITTED.* SUITABLE PITS OR TRENCHES SHALL BE EXCAVATED FOR CONDUCTING THE BORING OPERATIONS AND FOR PLACING THE HFPPL WORK SHALL BE SEALED SECURELY AND BRANDED IN A MANNER SATISFACTORY TO PREVENT EARTH CAVING AND IN ACCORDANCE WITH A TRENCH EXCAVATION AND SHORING SHEET PILE PLAN.
 3. DIRECTIONAL BORE METHOD. THE DIRECTIONAL BORE METHOD OF INSTALLATION OF THE PIPELINE OR OTHER PROPOSED FACILITY SHALL BE BORED A MINIMUM OF TWENTY PLUS (20+) FEET BELOW TOE OF WALL SECTION TO BE CROSSED. ENTRANCE AND DISCHARGE SITES OF SAID BORING SHALL BE OUTSIDE OF THE DISTRICT'S RIGHT OF WAY. THE DIRECTIONAL DRILLING PROCESS SHALL INCLUDE A MAGNETIC OR WIRE LINE GUIDANCE SYSTEM. THE RESULTS OF THE GUIDANCE SYSTEM SHALL BE DELIVERED TO THE DISTRICT FOR RECORD.
 4. MOST PREFERRED INSTALLATION, IS BY DIRECTIONAL BORING.
- IF UNCONSOLIDATED SOIL FORMATIONS ARE ENCOUNTERED, A GEL-FORMING COLLOIDAL DRILLING FLUID CONSISTING OF AT LEAST 10 PERCENT OF HIGH GRADE GENUINELY PROCESSED BENTONITE MAY BE USED TO CONSOLIDATE THE CUTTINGS OF THE BORE, SEAL THE WALLS OF THE HOLE, AND TURNISH LUBRICATION FOR SUBSEQUENT REMOVAL OF CUTTING AND INSTALLATION OF THE PIPE IMMEDIATELY THEREAFTER.

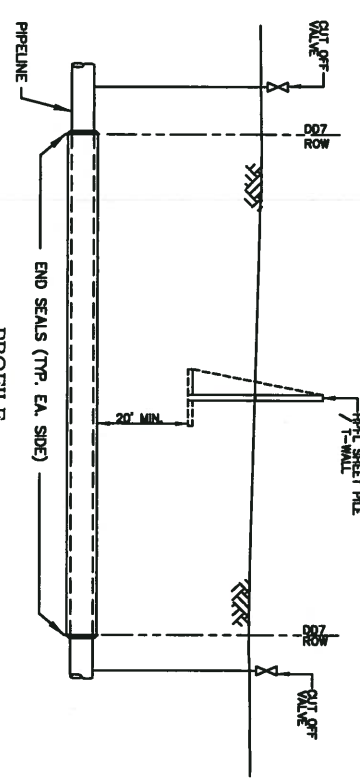

TYPICAL PIPELINE CROSSING - HFPPL WALL
CASEMENT

HORIZONTAL/DIRECTIONAL BORE
HURRICANE FLOOD PROTECTION LEVEE (HFPPL)
VERTICAL WALL/SHEETPILE



DGN. BY: R.J. MITCHELL
DWN. BY: ORW
CHECKED: R.J. MITCHELL
FINAL CHECK: EAL
REVISED: 09/13/12
DETAIL #: 25

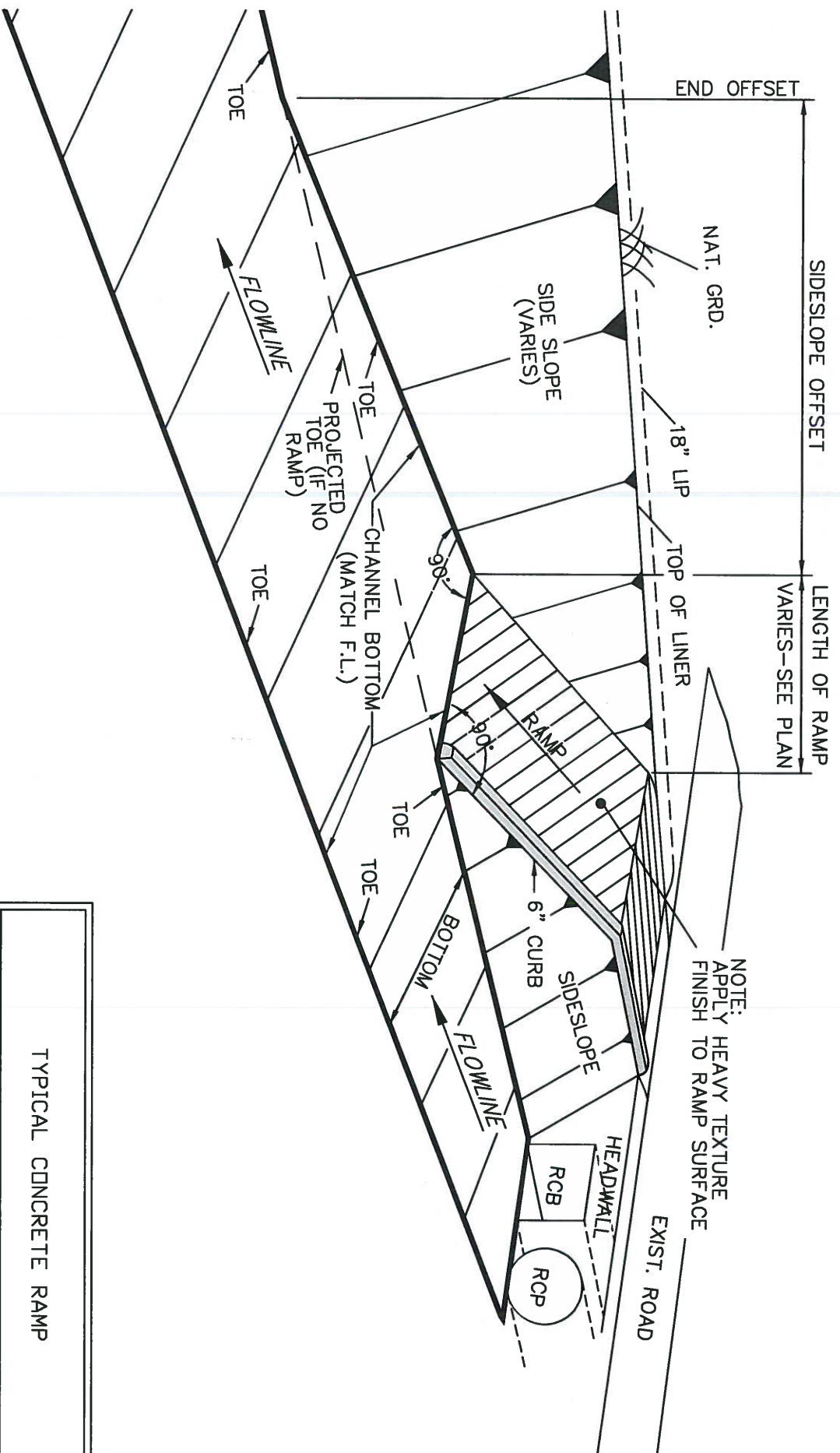

NOTE:
APPLY HEAVY TEXTURE
FINISH TO RAMP SURFACE

- NOTES: 1. REFER TO PROJECT PLANS FOR SPECIFIC DIMENSIONS
2. DO NOT CONSTRUCT RAMP WITH A CROSS-SLOPE.

TYPICAL CONCRETE RAMP

DGN. BY: R.J. MITCHELL
 DWN. BY: CRW
 CHECKED: EAL
 FINAL CHECK: EAL
 REVISED: 11/29/12
 DETAIL #: 26



ADD'T'L STEEL REINFORCEMENT @ PIER

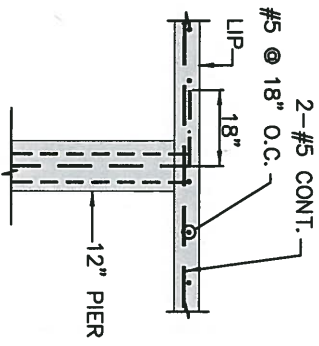

SECTION B-B

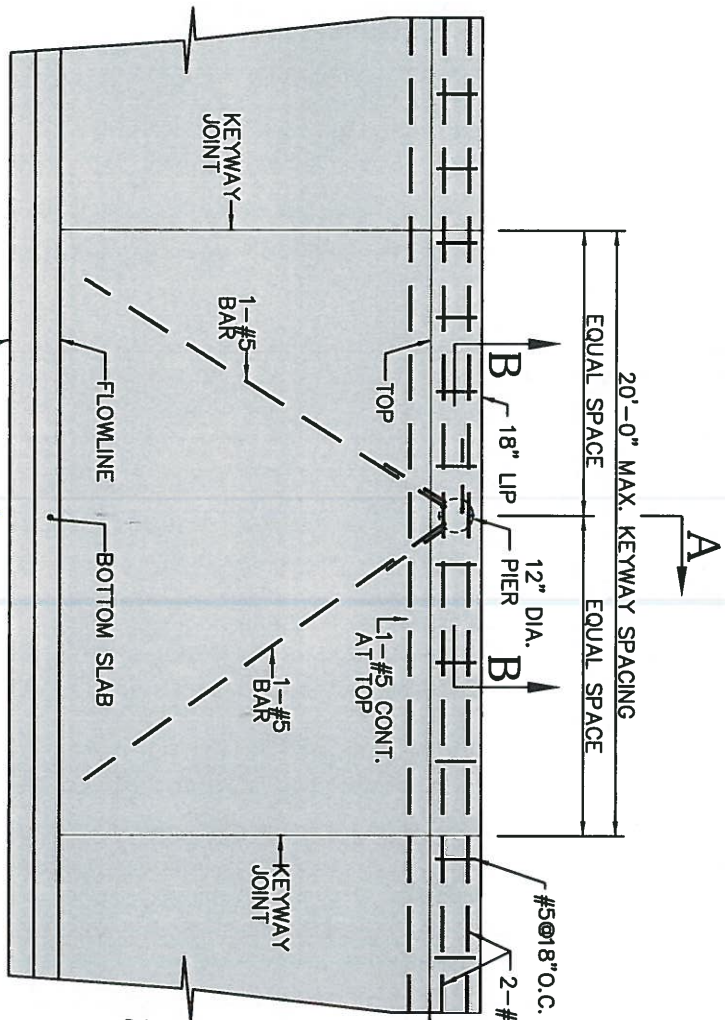

SECTION A-A

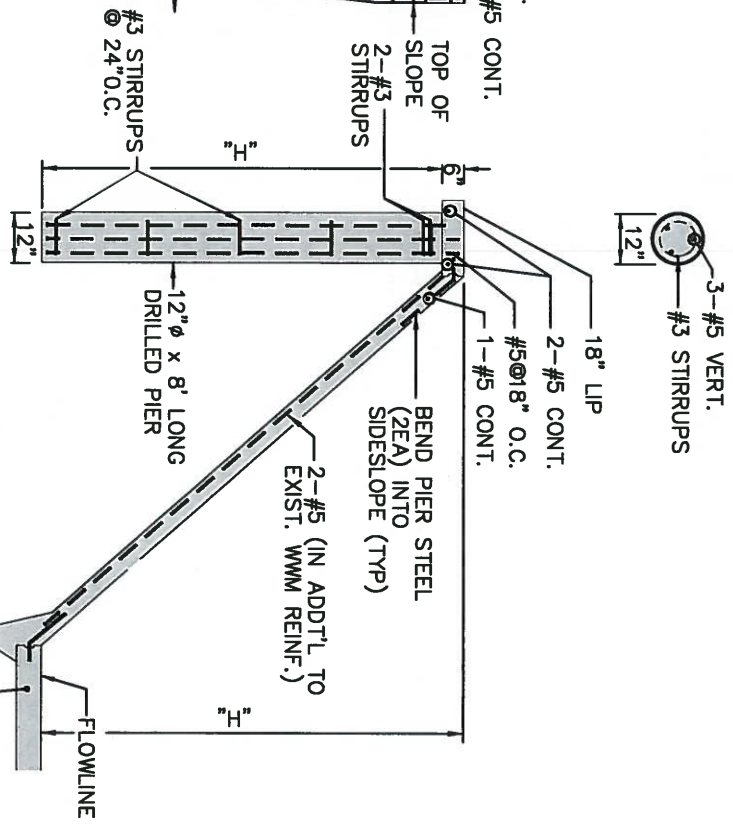

- NOTES:
1. DEPTH (H) OF PIER SHALL HAVE A MINIMUM DEPTH EQUAL TO THE HEIGHT OF SIDESLOPE (H). REFER TO CONSTRUCTION PLANS FOR DETAILED DIMENSIONS.
 2. PIERS SHALL BE LOCATED AT THE CENTERS OF EACH PANEL. "PIER-TO-PIER" SPACING MAY BE DECREASED, IF NECESSARY, TO PROVIDE ADDITIONAL STABILITY WHEN NEAR STRUCTURES.
 3. REFER TO STANDARD CONCRETE CHANNEL DETAILS, IN CONSTRUCTION PLANS, FOR TYPICAL CONCRETE REINFORCEMENT REQUIREMENTS.

ADDITIONAL SIDESLOPE PIER REINFORCEMENT



DGN. BY: R.J. MITCHELL
 DWN. BY: CRW
 CHECKED: EAL
 REVISED: 12/07/12
 DETAIL #: 27

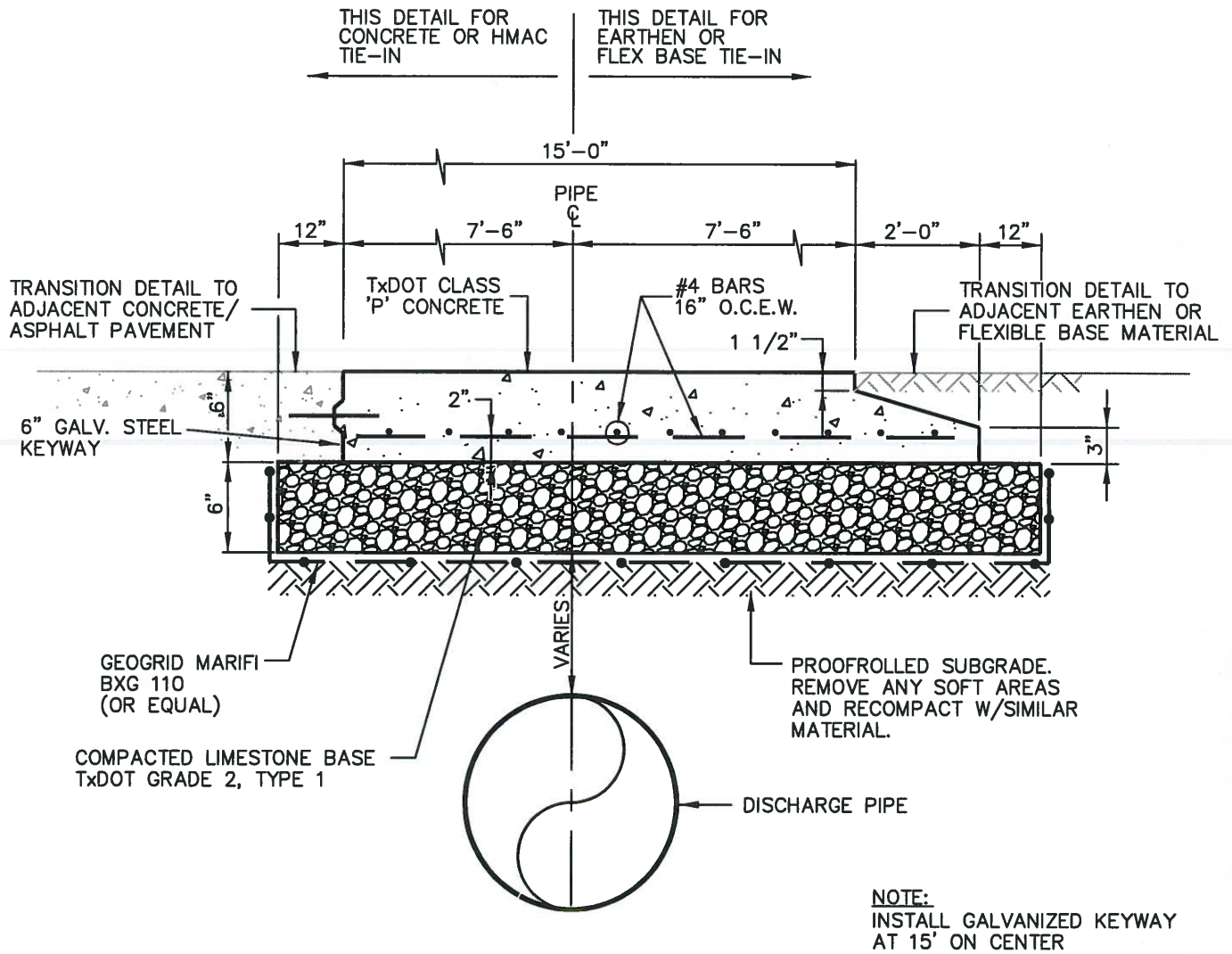

TYPICAL PROTECTION SLAB

N.T.S.

TYPICAL PROTECTION SLAB	
DGN. BY:	EAL
DWN. BY:	CRW
CHECKED:	R.J. MITCHELL
FINAL CHECK:	EAL
REVISED:	02/11/14
DETAIL #:	28

